

Products & Technology

Amana R-32 S-Series Installation and Commissioning
Technical Training Module TRV-15.1

R32



Rest assured.
It's an Amana® brand.



© 2024 Daikin Comfort Technologies North America, Inc.
Amana® is a registered trademark of Maytag Corporation or its related companies and is used under license.
All rights reserved.



Disclaimer

This material provides technical information that is to only be used by appropriately trained and certified HVAC-R installers and technicians who have agreed to the terms and conditions available here at <https://www.daikincity.com/DaikinCityB2BTermsOfUse.html>. If you have not agreed to these terms and conditions, you may not use or view this material, and you assume responsibility for any injury or property, system or equipment damage which may result. If you have agreed to these terms, you also agree, by viewing or using this material, that this material, by its nature, cannot include a discussion of everything necessary to effect a proper installation or repair of HVAC-R equipment, nor can it address every possible scenario or environment a technician or installer may encounter. Accordingly, this material should not be considered as recommendations for best practices and will not be considered installation or repair instructions to the extent of any conflict with Daikin- or Goodman-issued manuals and specifications, or industry standards and regulations. Each installer or technician remains fully responsible for ensuring proper installation or repair of the HVAC-R equipment being worked on, and you remain fully responsible for any injury or property, system or equipment damage which may result from your installation. ©2024 Daikin Comfort Technologies North America, Inc., all rights reserved; recording, copying, or distribution of this material is prohibited without express written permission from Daikin.

Amana® is a registered trademark of Maytag Corporation or its related companies and is used under license. All rights reserved.

Website Resources

Amana HAC

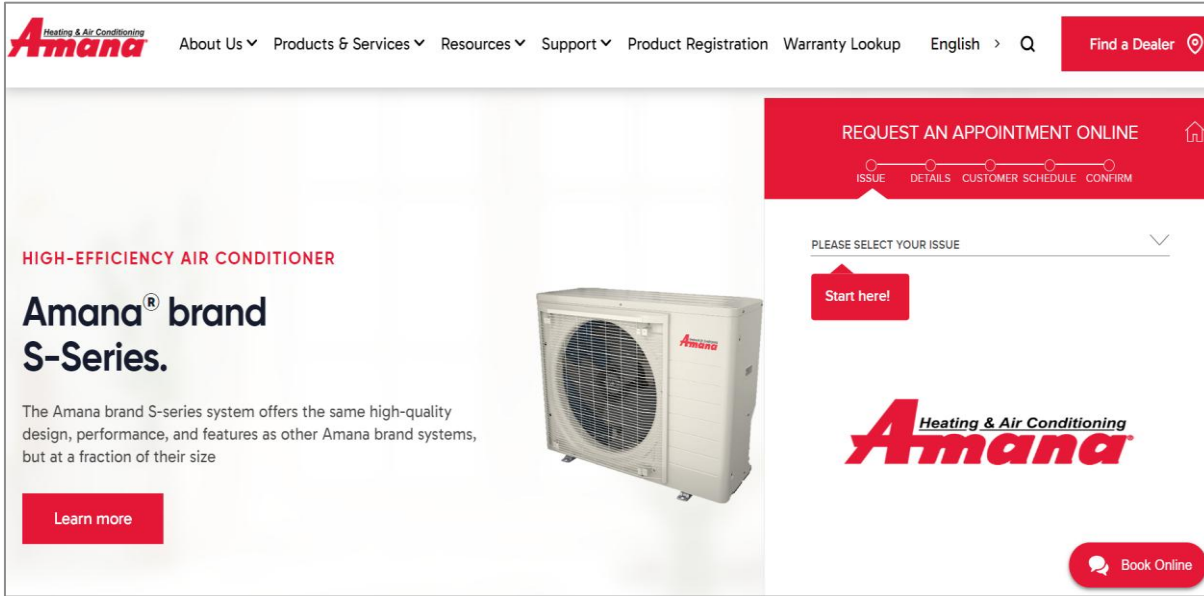

The screenshot shows the Amana Heating & Air Conditioning website. The top navigation bar includes links for About Us, Products & Services, Resources, Support, Product Registration, Warranty Lookup, and English. A search bar and a 'Find a Dealer' button are also present. The main content area features a large image of an Amana S-Series air conditioner. To the left of the image, the text reads 'HIGH-EFFICIENCY AIR CONDITIONER' and 'Amana® brand S-Series.' Below this, a short paragraph describes the system's quality and size. A 'Learn more' button is located at the bottom left. On the right side of the page, there is a red 'REQUEST AN APPOINTMENT ONLINE' banner with a progress bar showing steps: ISSUE, DETAILS, CUSTOMER SCHEDULE, and CONFIRM. Below the banner is a dropdown menu labeled 'PLEASE SELECT YOUR ISSUE' with a 'Start here!' button. The Amana logo is displayed at the bottom center, and a 'Book Online' button is at the bottom right.

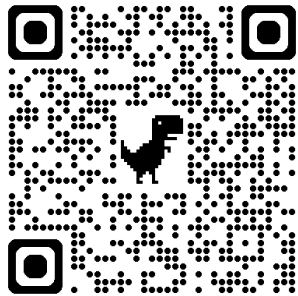

Partnerlink

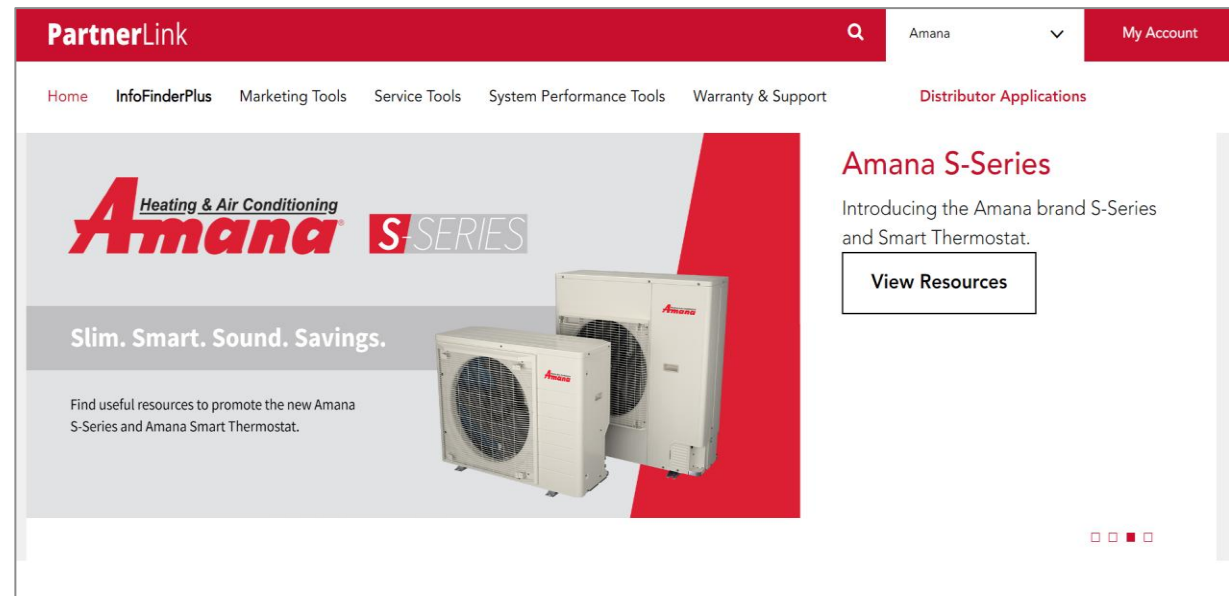

The screenshot shows the PartnerLink website. The top navigation bar includes a search bar, a dropdown menu for 'Amana', and a 'My Account' button. The main content area features a large image of two Amana S-Series air conditioners. To the left of the image, the text reads 'Slim. Smart. Sound. Savings.' and 'Find useful resources to promote the new Amana S-Series and Amana Smart Thermostat.' To the right of the image, the text reads 'Amana S-Series' and 'Introducing the Amana brand S-Series and Smart Thermostat.' A 'View Resources' button is located below the text. The Amana logo is displayed at the bottom center.

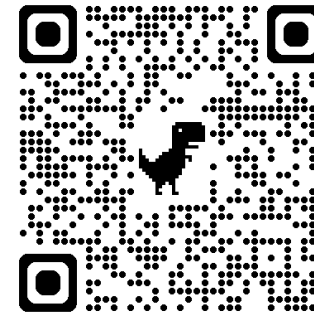

Resources

■ Daikin Tech Hub App



Quick easy, “on the go” access to:

- Daikin Technical & Service information directly in the fingertips
- Match-up and ratings
- Product/diagnostic information
- Documents, Support and more



- **User Friendly Interface**
- **Available on Apple® App Store or on Google Play™**

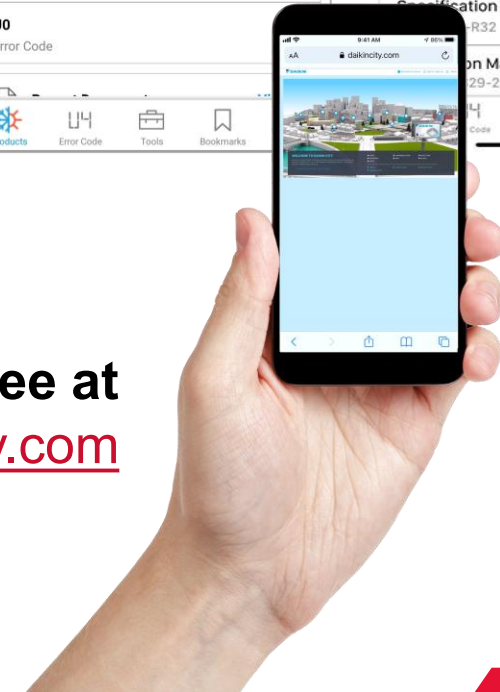
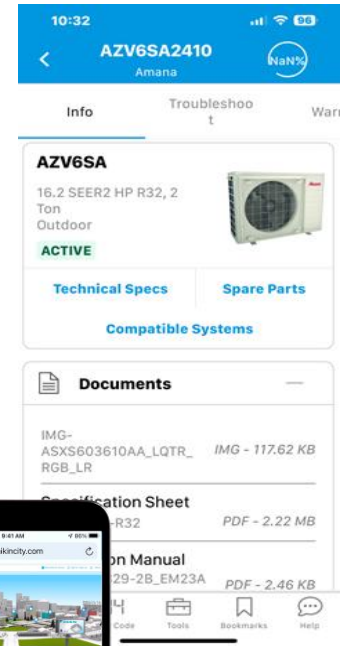
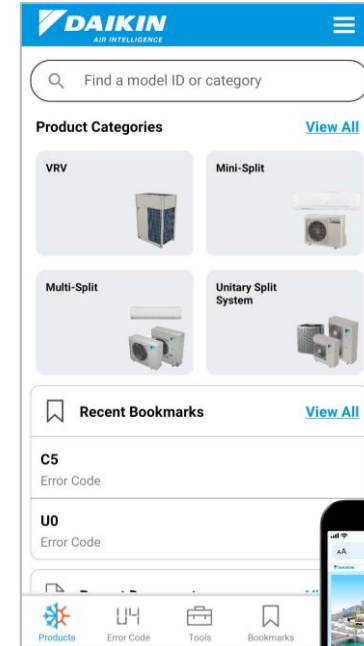
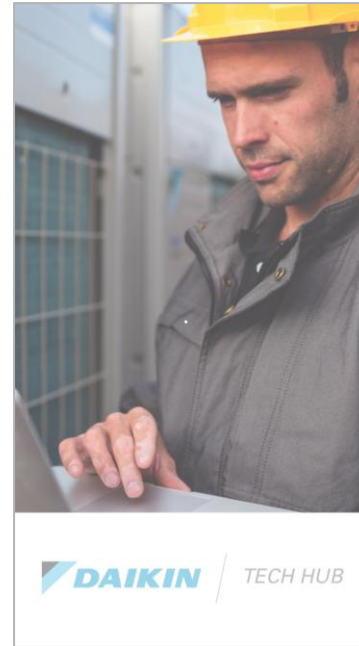

Sign-up for free at
www.daikincity.com

Installation Manual

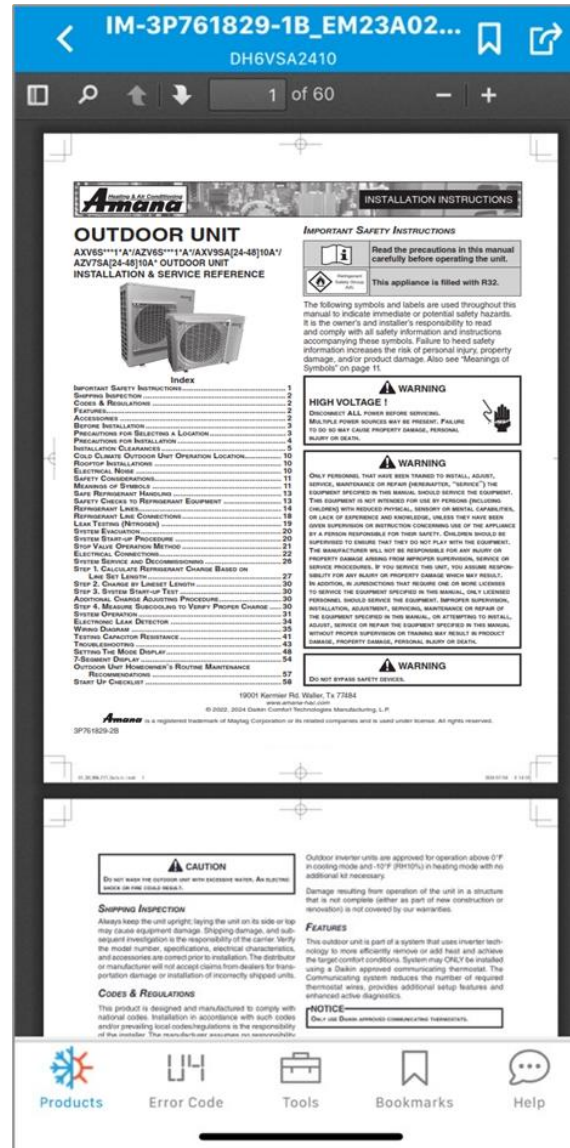
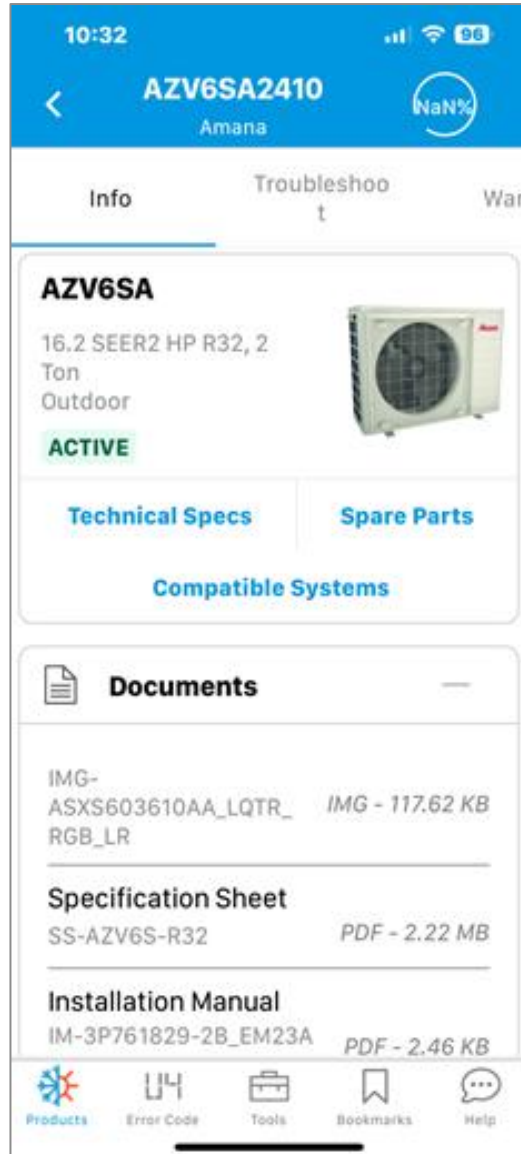

- Documents can be downloaded and stored on your mobile device.
 - Note: This is helpful if you need those documents but are outside of internet or cell service range.

Installation Manual

- All wiring diagrams, piping diagrams, Charging Tables, and system clearances can be found in the Installation manual for the equipment.
- When Installing a specific piece of equipment, it is always best to download the Installation manual specific to that piece of equipment
- This can be done with a computer using Daikin city or with a mobile device using the Tech Hub app.



INSTALLATION INSTRUCTIONS

OUTDOOR UNIT

AXV6S***1'A/AZV6S***1'A/AXV9SA[24-48]10A/
AZV7SA[24-48]10A' OUTDOOR UNIT

INSTALLATION & SERVICE REFERENCE



Index

IMPORTANT SAFETY INSTRUCTIONS.....	1
SHIPPING INSPECTION.....	2
CODES & REGULATIONS.....	2
FEATURES.....	2
ACCESSORIES.....	2
BEFORE INSTALLATION.....	3
PRECAUTIONS FOR SELECTING A LOCATION.....	3
PRECAUTIONS FOR INSTALLATION.....	4
INSTALLATION CLEARANCES.....	5
COLD CLIMATE OUTDOOR UNIT OPERATION LOCATION.....	10
ROOFTOP INSTALLATIONS.....	10
ELECTRICAL NOISE.....	10
SAFETY CONSIDERATIONS.....	11
MEANINGS OF SYMBOLS.....	11
SAFE REFRIGERANT HANDLING.....	13
SAFETY CHECKS TO REFRIGERANT EQUIPMENT.....	13
REFRIGERANT LINES.....	14
REFRIGERANT LINE CONNECTIONS.....	18
LEAK TESTING (NITROGEN).....	19
SYSTEM EVACUATION.....	20
SYSTEM START-UP PROCEDURE.....	20
STOP VALVE OPERATION METHOD.....	21
ELECTRICAL CONNECTIONS.....	22
SYSTEM SERVICE AND DECOMMISSIONING.....	26
STEP 1. CALCULATE REFRIGERANT CHARGE BASED ON LINE SET LENGTH.....	27
STEP 2. CHARGE BY LINESET LENGTH.....	30
STEP 3. SYSTEM START-UP TEST.....	30
ADDITIONAL CHARGE ADJUSTING PROCEDURE.....	30
STEP 4. MEASURE SUBCOOLING TO VERIFY PROPER CHARGE.....	30
SYSTEM OPERATION.....	31
ELECTRONIC LEAK DETECTOR.....	34
WIRING DIAGRAM.....	35
TESTING CAPACITOR RESISTANCE.....	41
TROUBLESHOOTING.....	43
SETTING THE MODE DISPLAY.....	48
7-SEGMENT DISPLAY.....	54
OUTDOOR UNIT HOMEOWNER'S ROUTINE MAINTENANCE RECOMMENDATIONS.....	57
START UP CHECKLIST.....	58

19001 Kermier Rd. Waller, Tx 77484
www.amana-hac.com
© 2022, 2024 Daikin Comfort Technologies Manufacturing, L.P.

Amana is a registered trademark of Maytag Corporation or its related companies and is used under license. All rights reserved.

3P761829-2B

IMPORTANT SAFETY INSTRUCTIONS



Read the precautions in this manual carefully before operating the unit.



This appliance is filled with R32.

The following symbols and labels are used throughout this manual to indicate immediate or potential safety hazards. It is the owner's and installer's responsibility to read and comply with all safety information and instructions accompanying these symbols. Failure to heed safety information increases the risk of personal injury, property damage, and/or product damage. Also see "Meanings of Symbols" on page 11.

WARNING

HIGH VOLTAGE !

DISCONNECT ALL POWER BEFORE SERVICING. MULTIPLE POWER SOURCES MAY BE PRESENT. FAILURE TO DO SO MAY CAUSE PROPERTY DAMAGE, PERSONAL INJURY OR DEATH.

WARNING

ONLY PERSONNEL THAT HAVE BEEN TRAINED TO INSTALL, ADJUST, SERVICE, MAINTENANCE OR REPAIR (HEREINAFTER, "SERVICE") THE EQUIPMENT SPECIFIED IN THIS MANUAL SHOULD SERVICE THE EQUIPMENT. THIS EQUIPMENT IS NOT INTENDED FOR USE BY PERSONS (INCLUDING CHILDREN) WITH REDUCED PHYSICAL, SENSORY OR MENTAL CAPABILITIES, OR LACK OF EXPERIENCE AND KNOWLEDGE, UNLESS THEY HAVE BEEN GIVEN SUPERVISION OR INSTRUCTION CONCERNING USE OF THE APPLIANCE BY A PERSON RESPONSIBLE FOR THEIR SAFETY. CHILDREN SHOULD BE SUPERVISED TO ENSURE THAT THEY DO NOT PLAY WITH THE EQUIPMENT. THE MANUFACTURER WILL NOT BE RESPONSIBLE FOR ANY INJURY OR PROPERTY DAMAGE ARISING FROM IMPROPER SUPERVISION, SERVICE OR SERVICE PROCEDURES. IF YOU SERVICE THIS UNIT, YOU ASSUME RESPONSIBILITY FOR ANY INJURY OR PROPERTY DAMAGE WHICH MAY RESULT. IN ADDITION, IN JURISDICTIONS THAT REQUIRE ONE OR MORE LICENSES TO SERVICE THE EQUIPMENT SPECIFIED IN THIS MANUAL, ONLY LICENSED PERSONNEL SHOULD SERVICE THE EQUIPMENT. IMPROPER SUPERVISION, INSTALLATION, ADJUSTMENT, SERVICING, MAINTENANCE OR REPAIR OF THE EQUIPMENT SPECIFIED IN THIS MANUAL, OR ATTEMPTING TO INSTALL, ADJUST, SERVICE OR REPAIR THE EQUIPMENT SPECIFIED IN THIS MANUAL WITHOUT PROPER SUPERVISION OR TRAINING MAY RESULT IN PRODUCT DAMAGE, PROPERTY DAMAGE, PERSONAL INJURY OR DEATH.

WARNING

DO NOT BYPASS SAFETY DEVICES.

© 2024 Daikin Comfort Technologies North America, Inc.

7

Utilizing Daikin Tech Hub

- Download the install manual for AZV6SA2410
- Utilizing the install manual find and verify MOP and correct breaker size.

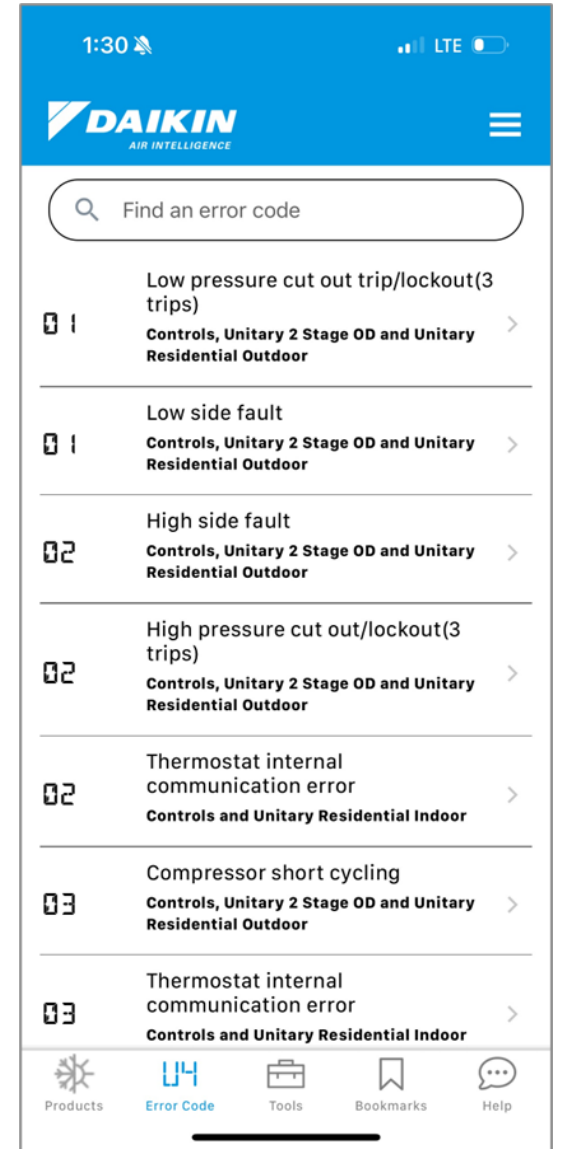
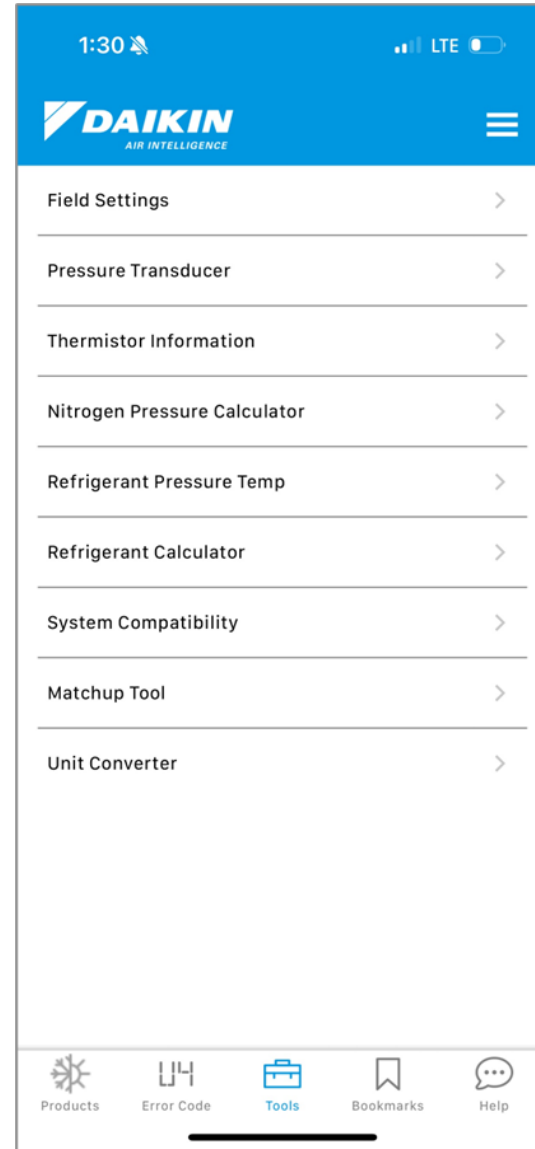

CoolCloud™ HVAC App



- The Amana Smart Thermostat must be utilized when setting up communication.

Note: This system is **NOT** Comfortbridge controlled. If wired to a Comfortbridge furnace, the installer must check for critical OTA updates through the CoolCloud app. prior to commissioning.

- **Do not energize the controller until you have verified the critical OTA is complete.**

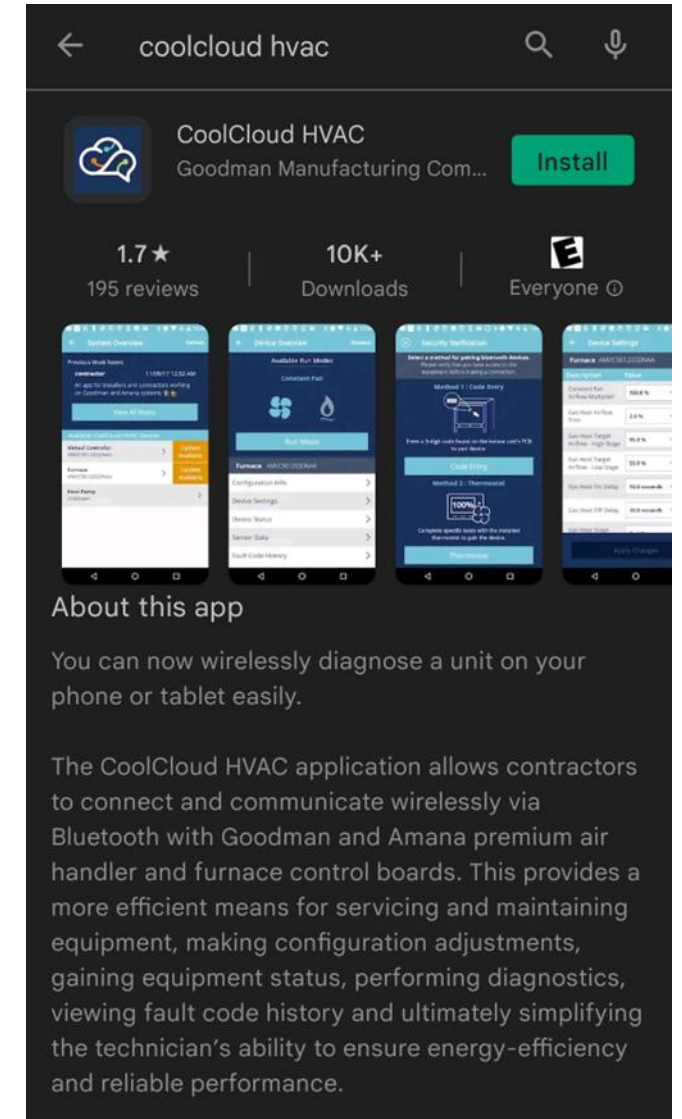

CoolCloud™ HVAC App

Download the CoolCloud™ HVAC application

- Where can I download the app?

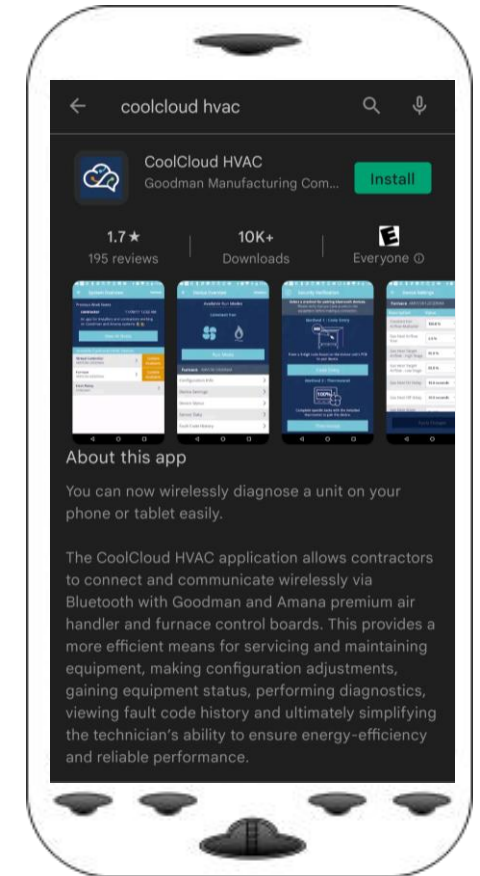
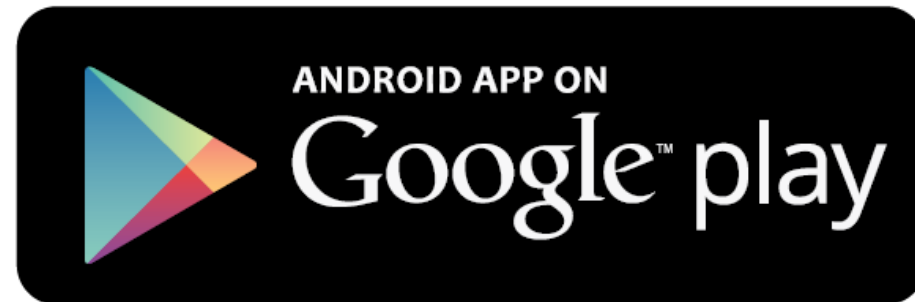

- The CoolCloud™ HVAC app is available in Apple® and Android™ versions.

Agenda

Tools and Resources

Product Information

Inverter Technology

Indoor Units

Controls

Nomenclature

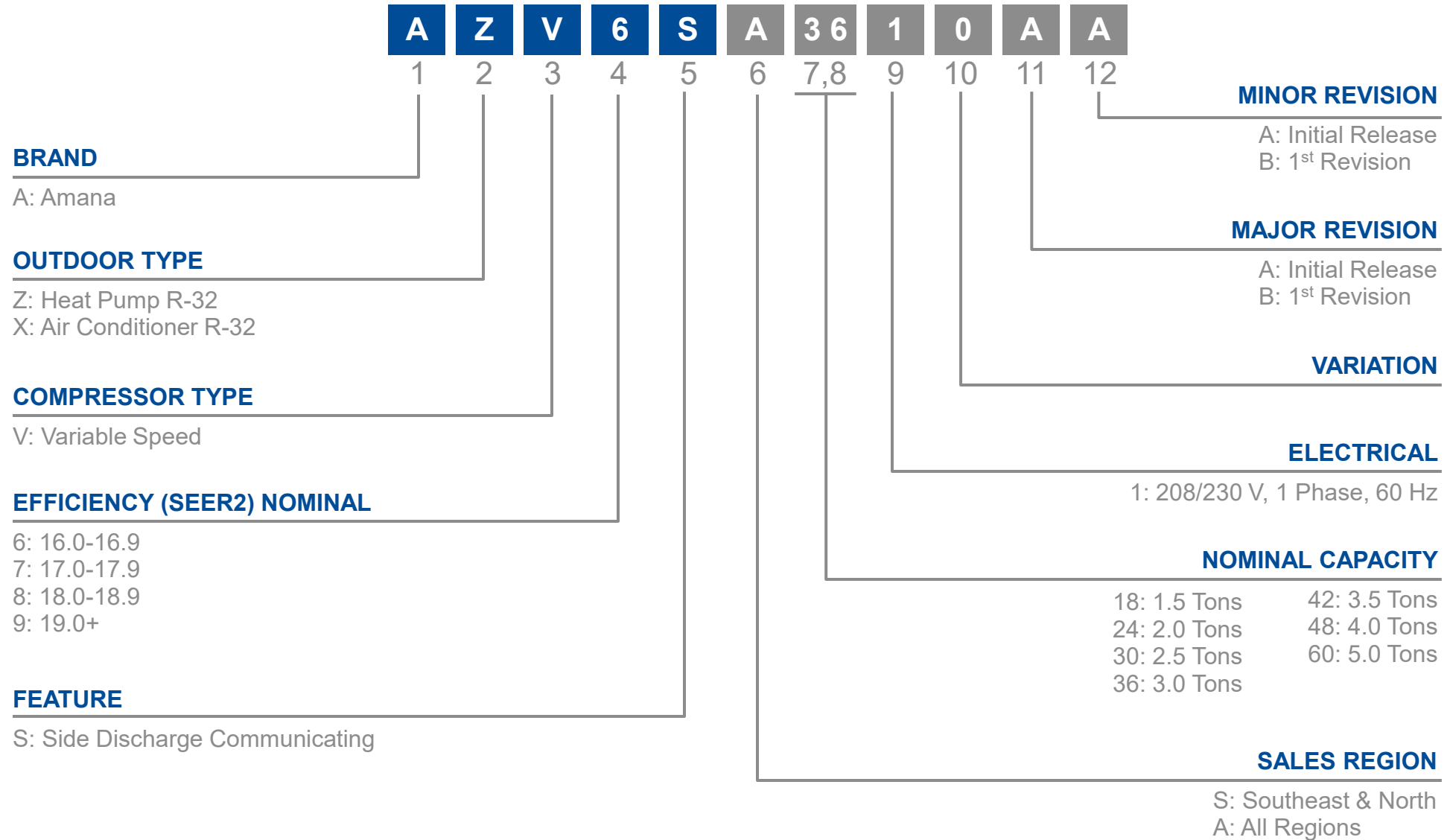



Single Fan Models

- Small chassis: 1.5-3-ton models
- Large chassis: 3.5-5-ton models
 - Utilizes a cooling loop to cool the inverter control board during operation
- Variable speed swing compressor in all models
- Digitally commutated outdoor fan motor
- Boost mode
- Coil and ambient temperature sensors
- Suction pressure transducer
- Utilizes Amana Smart Thermostat

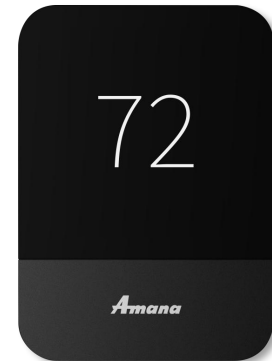



Double Fan Models

- Utilizes a cooling loop to cool the inverter control board during operation
- Variable speed swing compressor in all models
- Digitally commutated outdoor fan motors
- Boost mode
- Coil and ambient temperature sensors
- Suction pressure transducer
- Utilizes Daikin approved communicating thermostats





Single Fan Models

- Small chassis: 1.5-3-ton models
- Large chassis: 3.5-5-ton models
 - Utilizes a cooling loop to cool the inverter control board during operation
- Variable speed swing compressor in all models
- Digitally commutated outdoor fan motor
- Boost mode
- Coil, defrost and ambient temperature sensors
- High/low pressure transducer
- Utilizes Amana Smart Thermostat

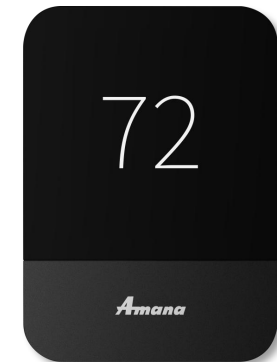
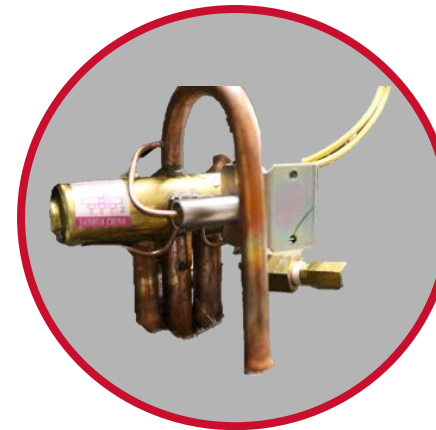



Double Fan Models

- 2, 3, 4 & 5-ton models
 - Utilizes a cooling loop to cool the inverter control board during operation
- Variable speed swing compressor in all models
- Digitally commutated outdoor fan motors
- Boost mode
- Coil, defrost and ambient temperature sensors
- High/low pressure transducer
- Utilizes Daikin approved communicating thermostats

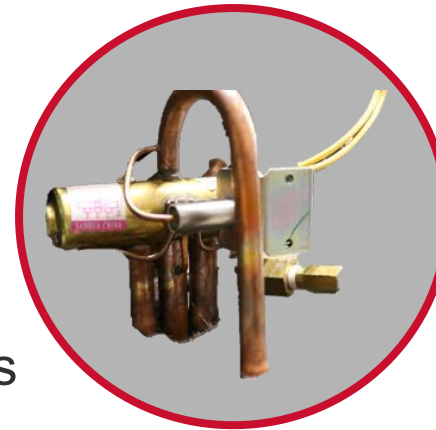

Swing vs. Rotary Compressor



- Integration of main moving parts into one component.
 - Eliminates wear at contact point.
 - Eliminates refrigerant leakages.
- This results in greater compressor efficiency.
- Best compressor choice for capacities up to 60MBH.

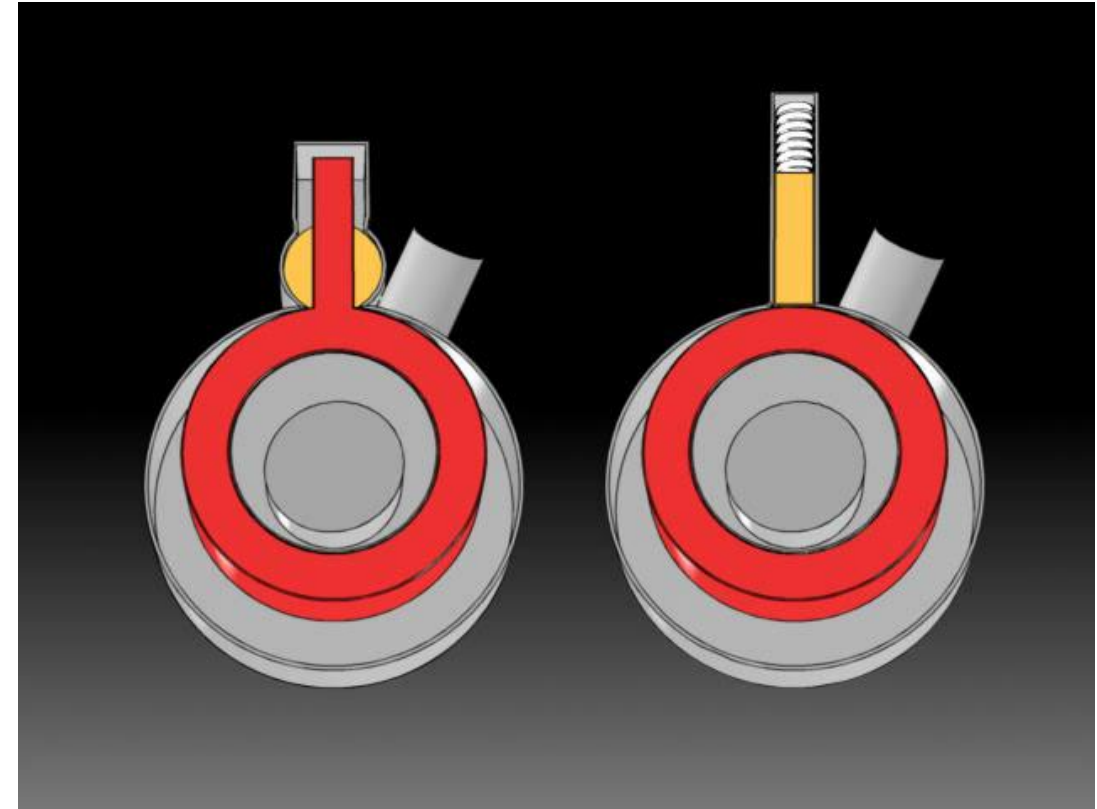
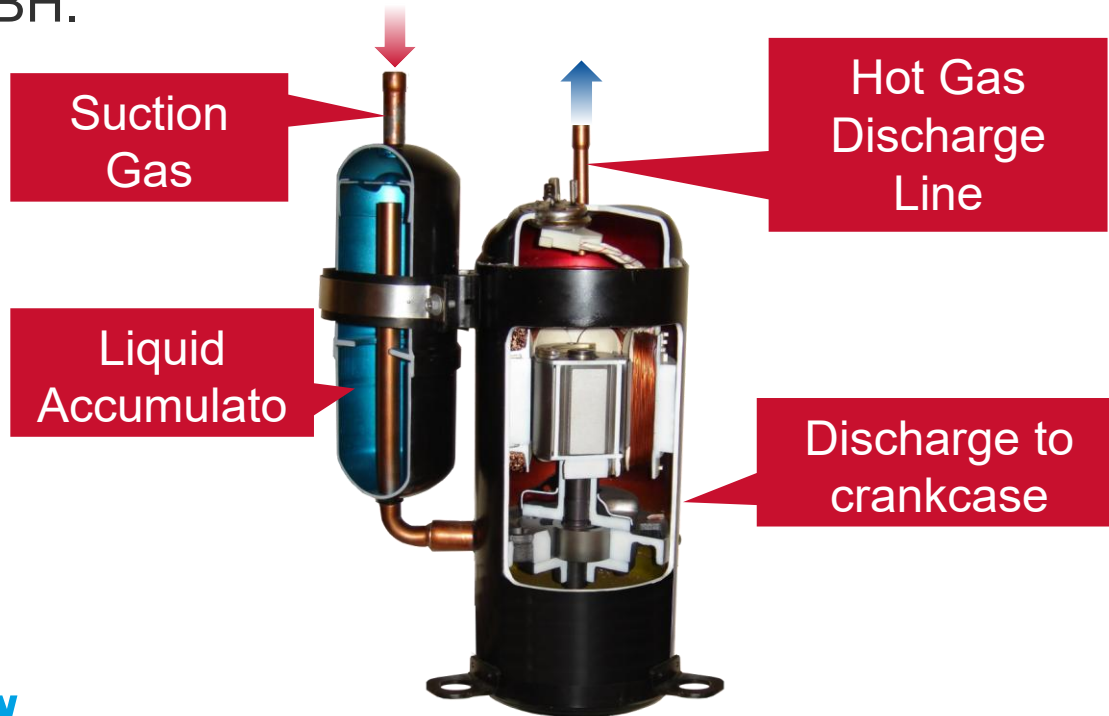

Electronic Expansion Valve

- Allows precision metering by responding instantly and continuously.
- Sensors input demand to open and close allowing the correct amount of refrigerant according to load requirement.
- EEV motor head can be replaced without recovering the refrigerant.
- Target superheat
 - Cooling: 9°F (5°C) - IDU EEV
 - Heating: 7°F (4°C) - ODU EEV

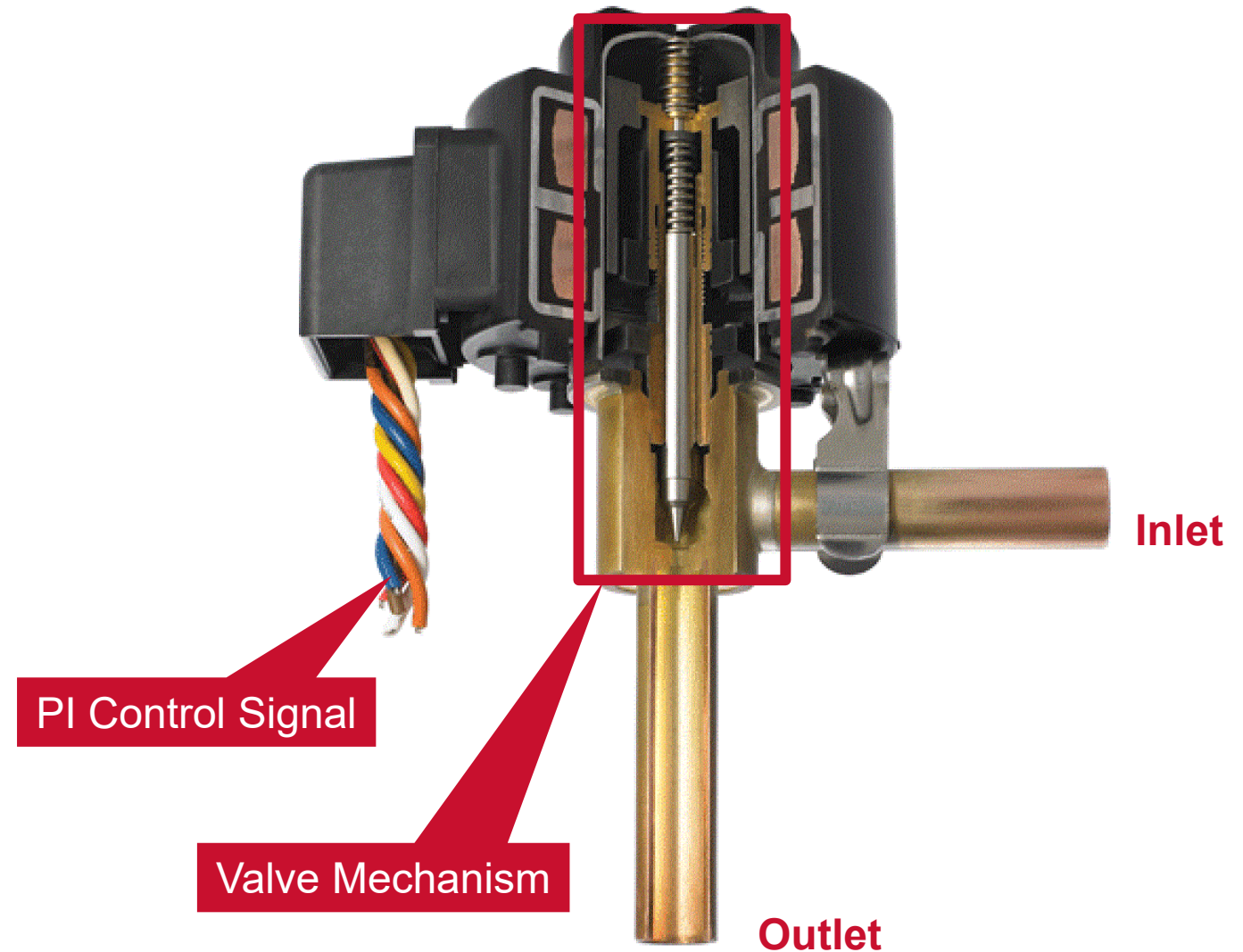

Agenda

Tools and Resources

Product Information

Inverter Technology

Indoor Units

Controls

Inverter Technology

- The inverter control rectifies the incoming ac voltage to dc voltage.
- The inverter then smooths the sine wave to eliminate dc buss ripple.
- Inverts the dc voltage to 3 phase ac voltage to the compressor.
- Frequency applied to the compressor motor modulates the rotational speed which varies the capacity.

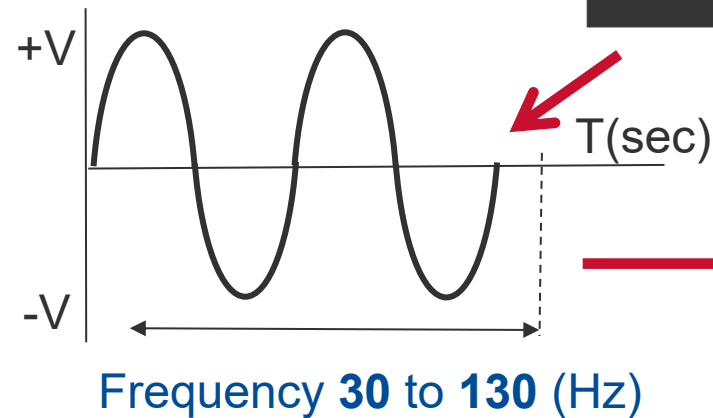
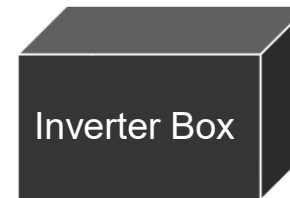
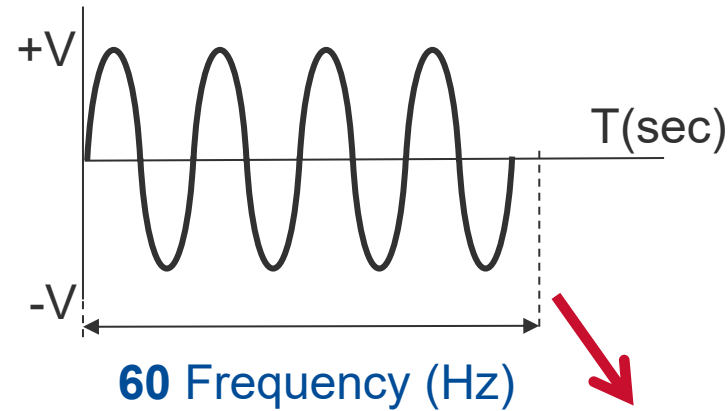

Multi-Step Principle

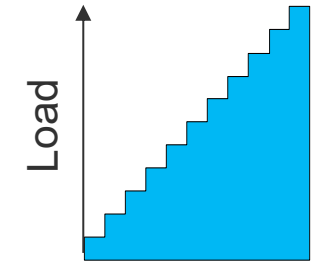

Multiple Capacity Steps
Applied frequency





- High efficiency in part-load conditions.
- Less locked rotor amps.
- Less stress on windings or compressor frame.
- System pressures increase gradually reducing noise and stress on piping.
- Quiet compressor startup.
- As room temperature nears set point capacity is automatically throttled down.
- Longer run periods at lower capacities.
- Fewer compressor starts mean less wear and tear on the compressor = longer life!





Agenda

Tools and Resources

Product Information

Inverter Technology

Indoor Units

Controls

AHVE

- Compatible with the Amana Smart Thermostat.
- High/low pressure transducer.
- Electronic Expansion Valve (EEV) for cooling and heat pump applications.
- Variable-speed ECM blower.
- Provides constant CFM over a wide range of static pressure conditions.
- Horizontal or vertical configuration.
- 7mm coil tubing.



MBVK

- Variable-speed ECM blower.
- Compatible with Amana Smart Thermostat.
- Advanced configuration of the airflow and tonnage in communicating mode.
- Provides constant CFM over a wide range of static pressure conditions independent of duct system.
- CFM indicator.
- Fault recall of six most recent faults.
- Blower section usable as electric heater.
- Horizontal or vertical configuration capabilities.



Cased Coils

Indoor coil options

- CAPEA Coil with Control Module
- CHPEA Coil with Control Module



Furnaces

- Compatible with Amana 80%, 96%, or 97% AFUE communicating furnace.
 - The D24V Gateway allows you to connect to any non-communicating gas furnace. (AC ONLY)



Agenda

Tools and Resources

Product Information

Inverter Technology

Indoor Units

Controls

Cloud Services >>> SkyportCare and SkyportHome

If you use these apps today, after 10/15/25 you use the **NEW SkyportHome** app!



If you use these apps today, after 10/15/25 you use the **NEW SkyportCare** app!



© 2025 Daikin Comfort Technologies North America, Inc. | 5



Installation & Commissioning

Amana S-Series R-32 Installation and Commissioning
Technical Training Module TRV-15.2

R32



Rest assured.
It's an Amana® brand.



© 2024 Daikin Comfort Technologies North America, Inc.
Amana® is a registered trademark of Maytag Corporation or its related companies and is used under license.
All rights reserved.



Agenda

Pre-Installation

Installation

Commissioning

ODU Location Considerations

- Always follow the instruction manual for equipment clearances.
 - Improper ODU placement can cause adverse operation of the equipment. (i.e., short cycling, defrost, etc.)
- Do not stack more than two units. (20" vertical clearance between the ODUs)
- Sound vibration transmission should be considered when installing the unit.
- Ensure that the roof structure can support the weight of the unit.
 - Refer to specification sheets for ODU weight.
- Proper consideration should be given to the weather-tight integrity of the roof.
- Wind Baffle can be used to help limit air recirculation when there is a wall facing the outlet and no top.



Electrical Noise



- The inverter units should be well grounded.
 - This prevents the potential effects of electrical noise from the inverter to surrounding equipment.
- Keep enough distance from home stereos, personal computers, etc.
 - At least 60"

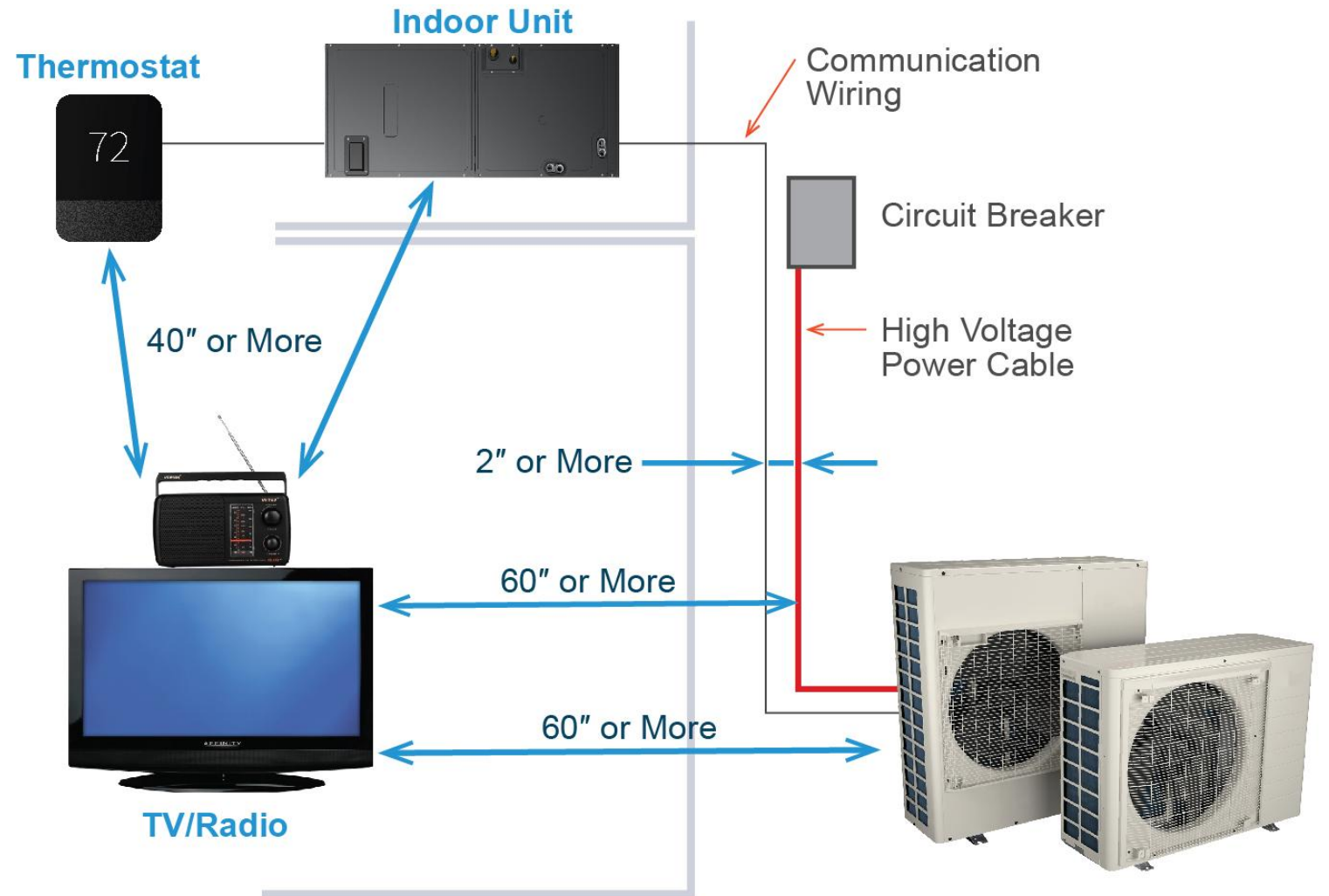

Bi-Flow Filter Drier



- A bi-flow filter drier is shipped with the unit as a separate component.
- If the paint of the steel filter drier has been burned or chipped, repaint or treat with a rust inhibitor.
- The recommended location of the filter drier is before the expansion device at the indoor unit.

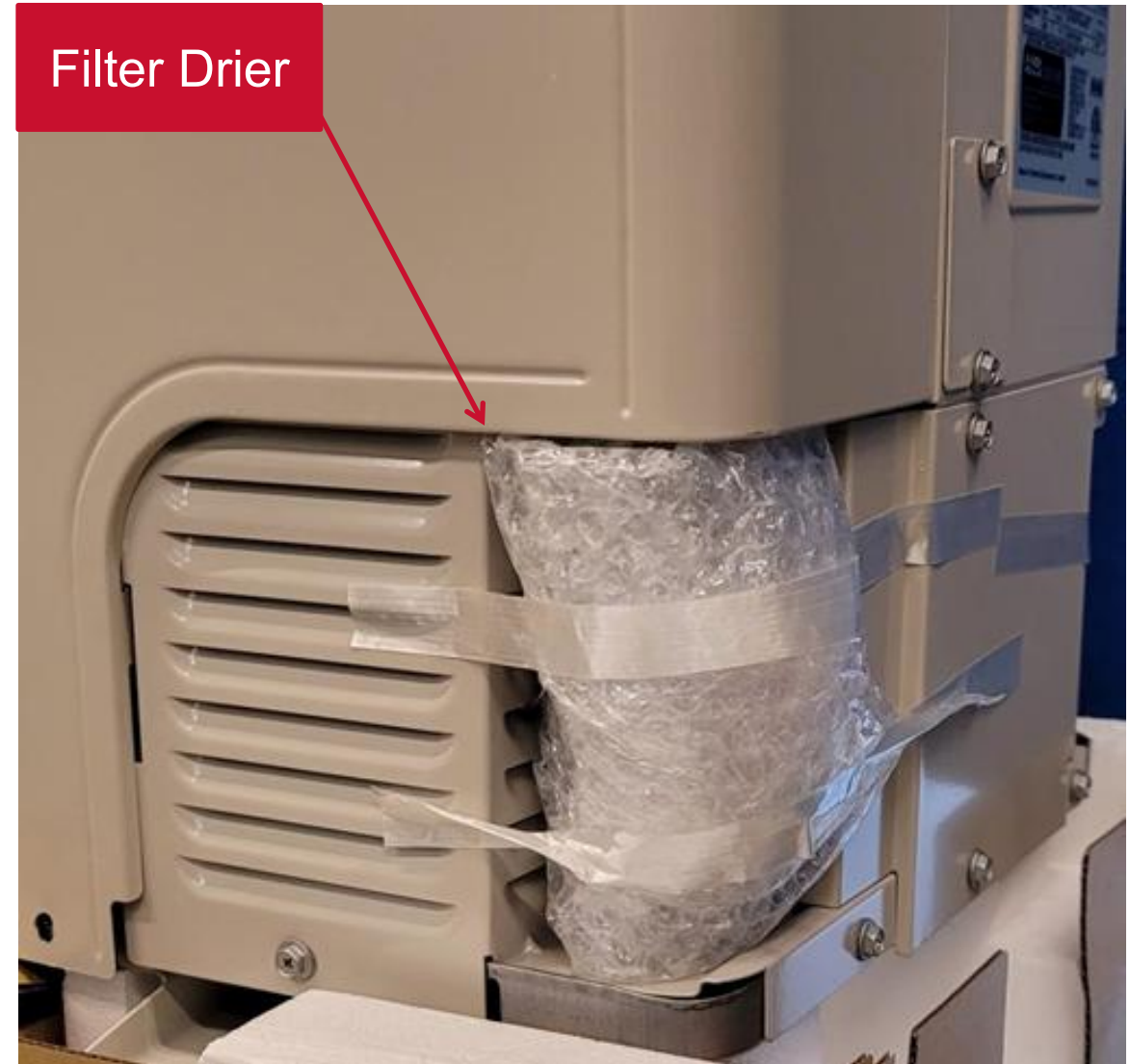

Removing Transport Bracket on Double Fan Models

- A yellow transport bracket and washer are attached to the leg of the compressor to protect the unit during transportation and must be removed before starting the system.

1. Open the sound-proof cover do not remove it from the compressor.
2. Remove the securing nut.
3. Remove the transport bracket as shown in the diagram.
4. Retighten the securing nut.
5. Return the sound-proof cover as it was.

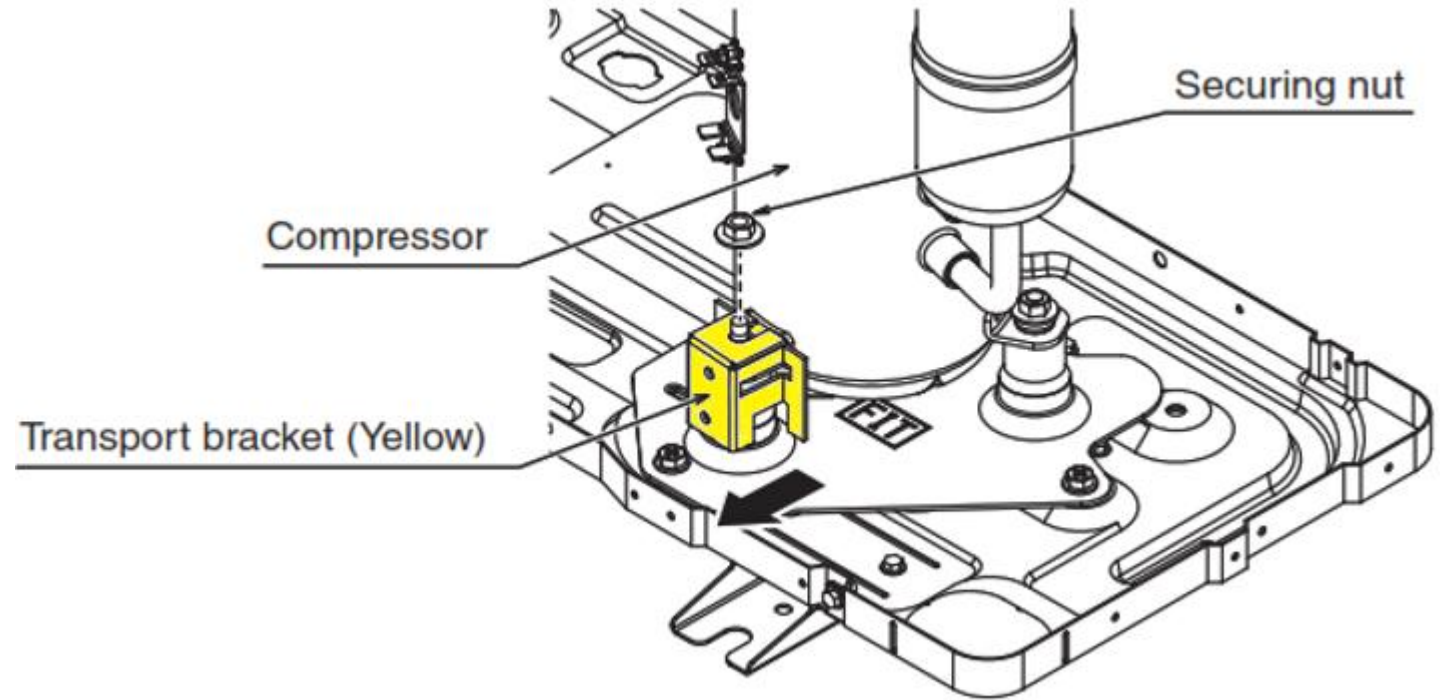

Agenda

Pre-Installation

Installation

Commissioning

Piping Diagram – Large Chassis HP

- Thermistor locations can be utilized to plot data that is identified on the D-Checker.

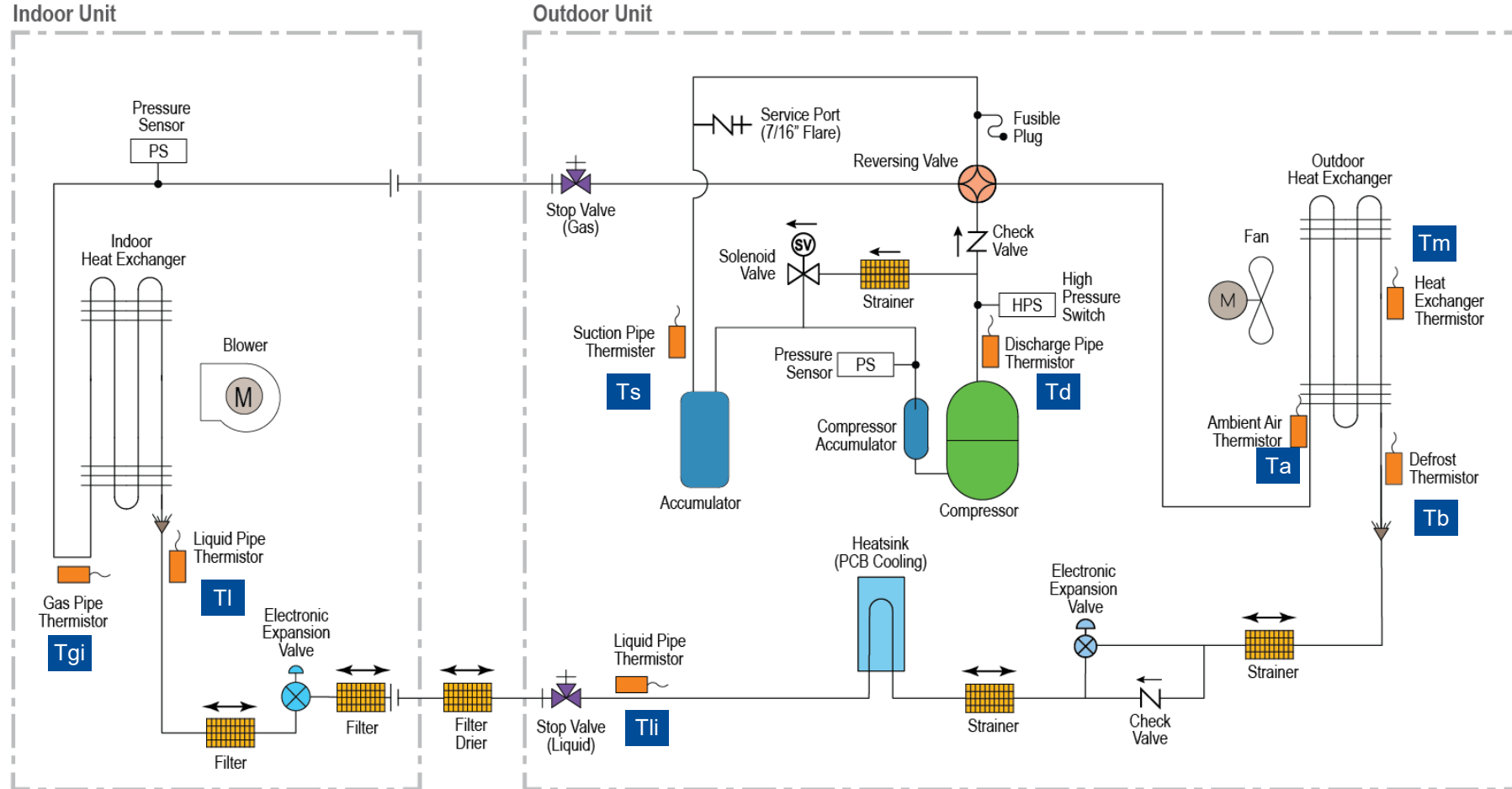

Refer to the service manual for piping diagrams

Piping Diagram –Double Fan Model HP

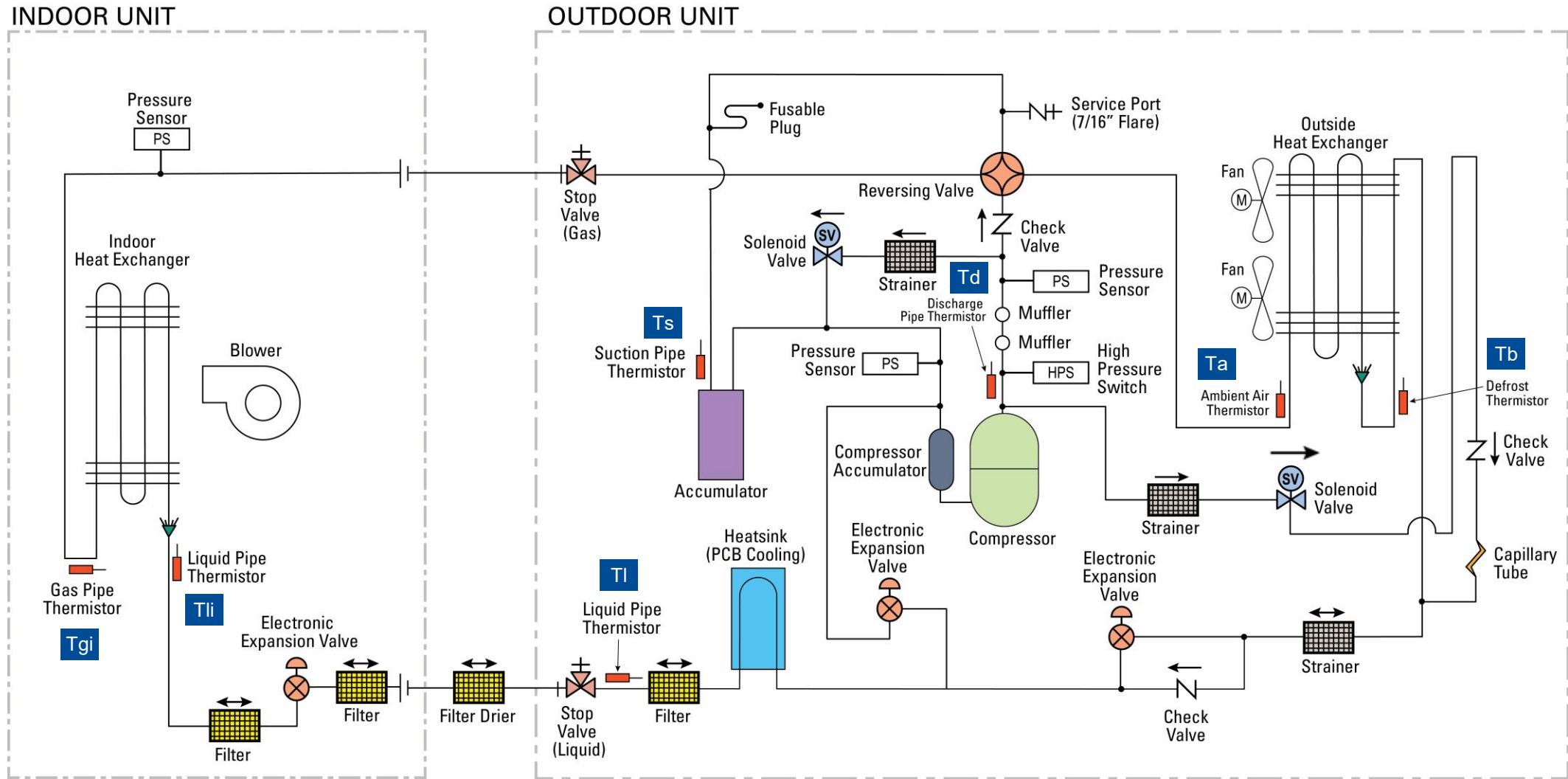

Refer to the service manual for piping diagrams

Insulating Refrigerant Lines

- The gas line must always be insulated between the indoor and outdoor units to prevent condensation from forming.
- The liquid line must be insulated if more than 50' of liquid line will pass through an area that may reach temperatures 30°F or higher than the outdoor ambient temperature.
 - Insulation must be installed in a manner which protects the tubing from damage and contamination.
 - Insulation with 3/8" wall thickness is recommended. In severe conditions (hot, high humidity areas) 1/2" insulation may be required.



Piping Support

- Tighten brackets so that they hold pipes in place but still allow for expansion.
- If hanging line set from a joist or rafter, use metal strapping or heavy nylon wire ties that are securely anchored.
 - Applications (>80'), refrigerant tubing is prone to transmit noise and vibration to the adjoining structure. Use adequate vibration-isolating hardware when mounting line set to structural members.

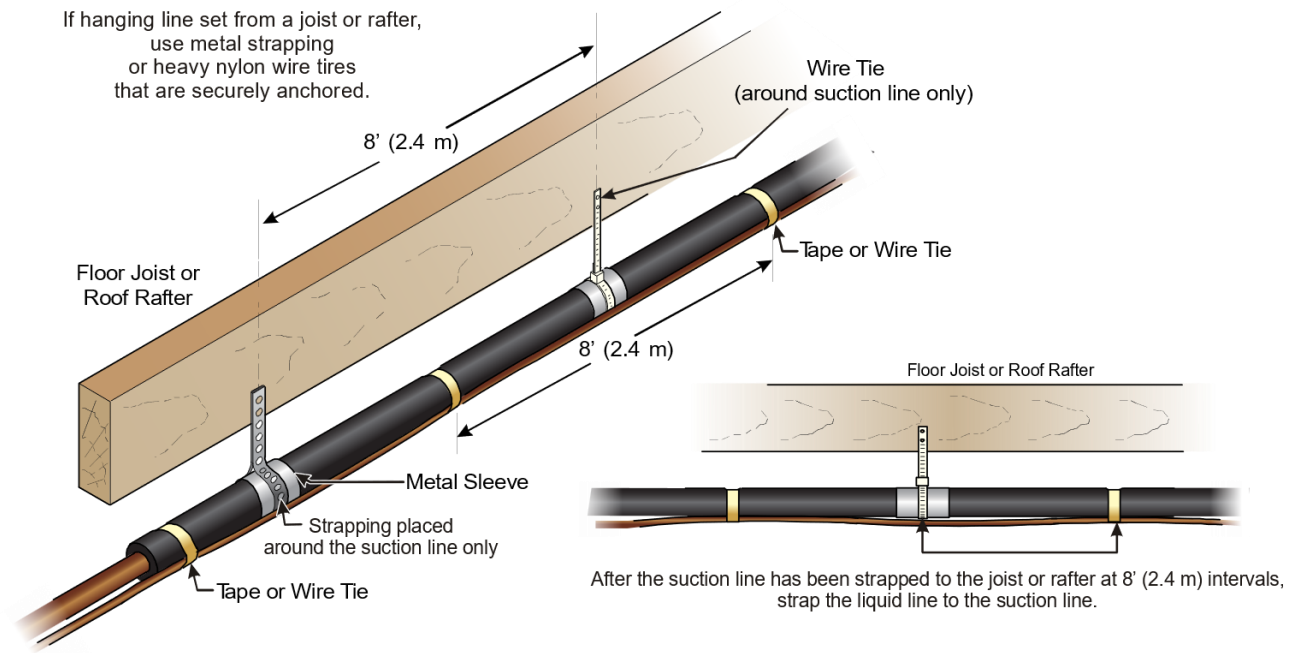
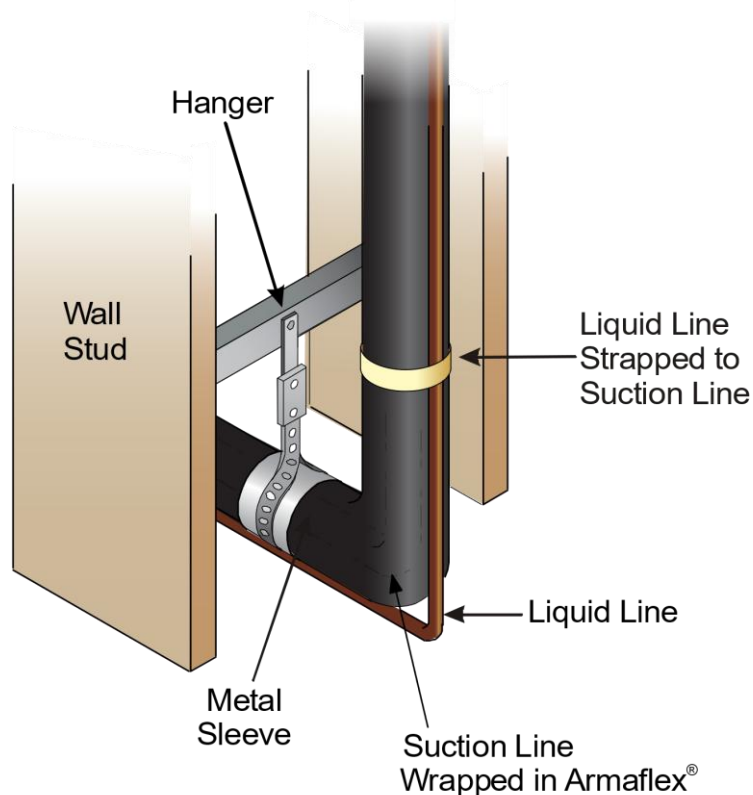

Existing Refrigerant Lines

- Drain as much residual compressor oil from existing line sets, and traps.
 - Pay close attention to low areas where oil may collect.
- If changing refrigerant or using existing refrigerant lines, you **MUST** flush the existing refrigerant lines.
 - Use a professional flushing agent to remove any excess oil or debris from the prior HVAC system.

Note: Legacy oil drainage and passive nitrogen flush recommended.



Refrigerant Piping Requirements

Outdoor Unit Above Indoor Unit

- Max. line set equivalent length of 125 ft.
 - Includes pressure losses of any elbows, bends etc.

Type of Elbow Fitting	Inside Diameter		
	3/4"	7/8"	1-1/8"
90° Short Radius	1.7'	2'	2.3'
90° Long Radius	1.5'	1.7'	1.6'
45° Radius	0.7'	0.8'	1'

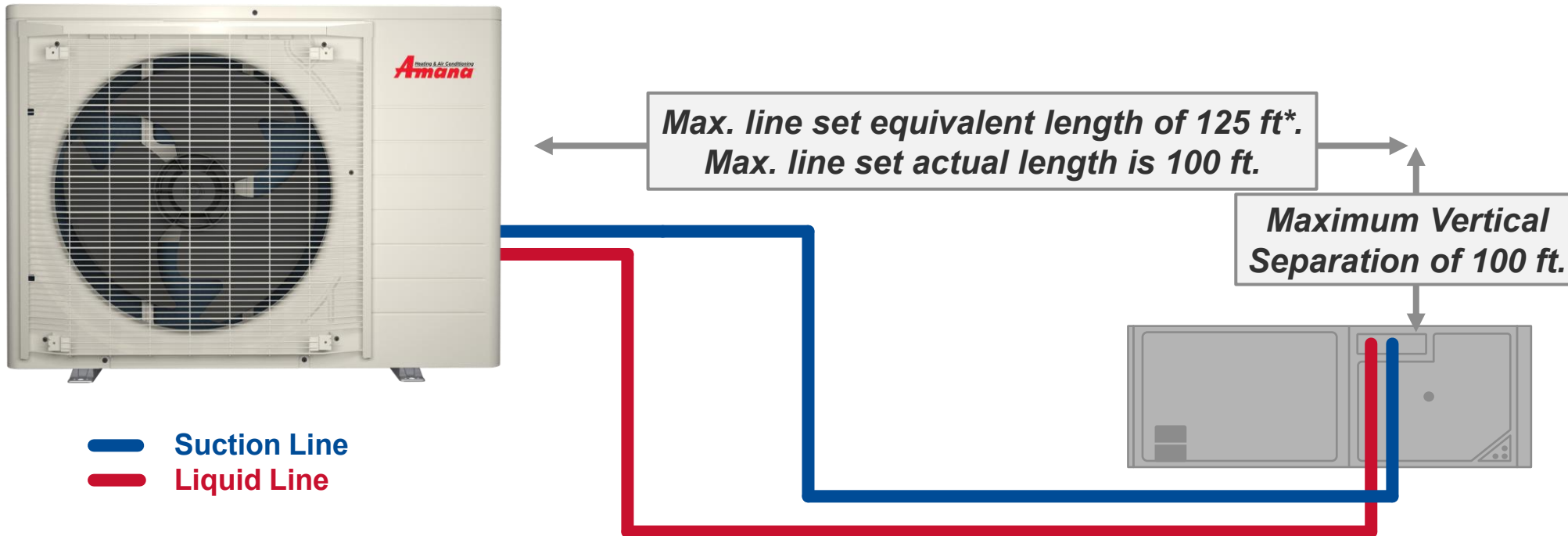

Refrigerant Piping Requirements

Outdoor Unit Below Indoor Unit

- Requires an inverted loop in the suction line near the connection to the indoor unit (prevents liquid migration to the outdoor unit from the indoor unit)
 - The top of the loop must be slightly higher than the top of the coil.
- Max. line set equivalent length of 125 ft.
 - Includes pressure losses of any elbows, bends, etc.

Type of Elbow Fitting	Inside Diameter		
	3/4"	7/8"	1-1/8"
90° Short Radius	1.7'	2'	2.3'
90° Long Radius	1.5'	1.7'	1.6'
45° Radius	0.7'	0.8'	1'

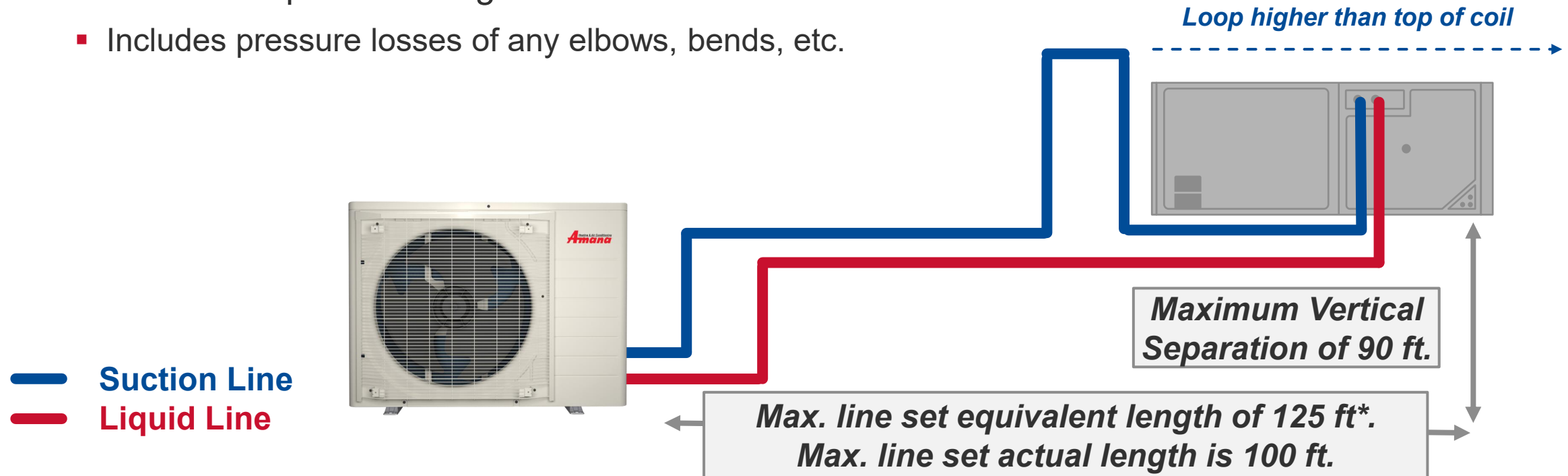

Refrigerant Piping Requirements Double Fan Models

Outdoor Unit Above Indoor Unit

- Max. line set equivalent length includes pressure losses of any elbows, bends, etc.



Type of Elbow Fitting	Inside Diameter		
	3/4"	7/8"	1-1/8"
90° Short Radius	1.7'	2'	2.3'
90° Long Radius	1.5'	1.7'	1.6'
45° Radius	0.7'	0.8'	1'

Cond Unit Tons	Max Line Set Length (ft.)	
	Equivalent A	Actual B
2.0	187.5'	150'
3.0	187.5'	150'
5.0	125'	100'

— Suction Line
— Liquid Line

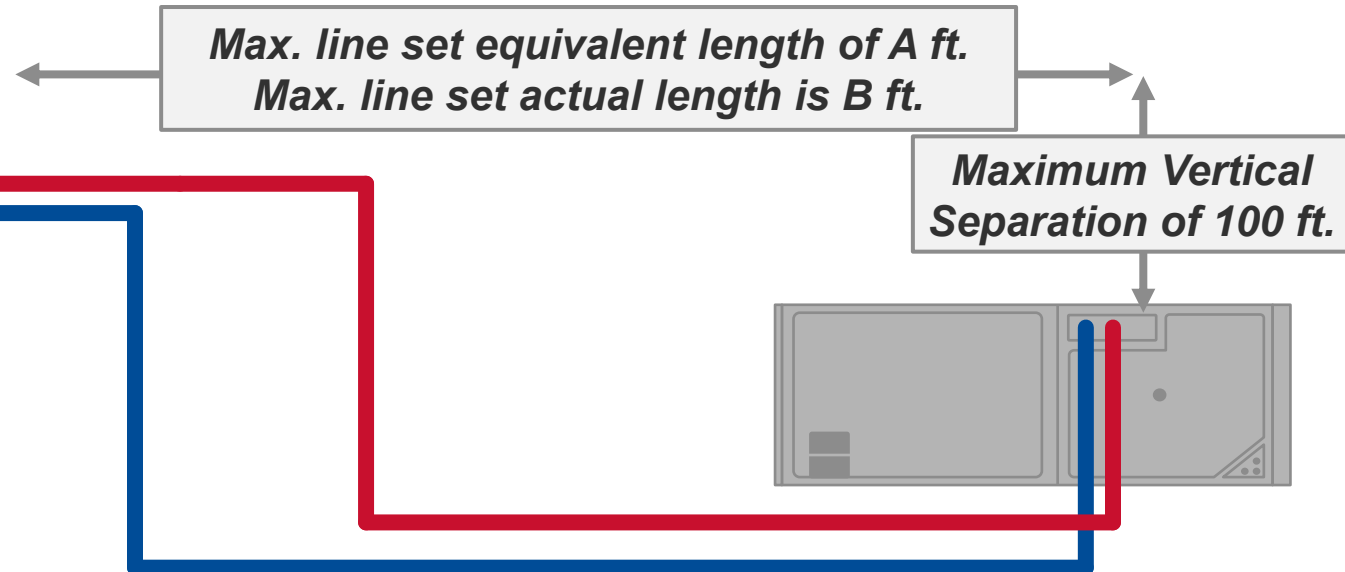

Refrigerant Piping Requirements Double Fan Models

Outdoor Unit Below Indoor Unit

- Max. line set equivalent length includes pressure losses of any elbows, bends, etc.

Type of Elbow Fitting	Inside Diameter		
	3/4"	7/8"	1-1/8"
90° Short Radius	1.7'	2'	2.3'
90° Long Radius	1.5'	1.7'	1.6'
45° Radius	0.7'	0.8'	1'

Cond Unit Tons	Max Line Set Length (ft.)	
	Equivalent	Actual
	A	B
2.0	187.5'	150'
3.0	187.5'	150'
5.0	125'	100'

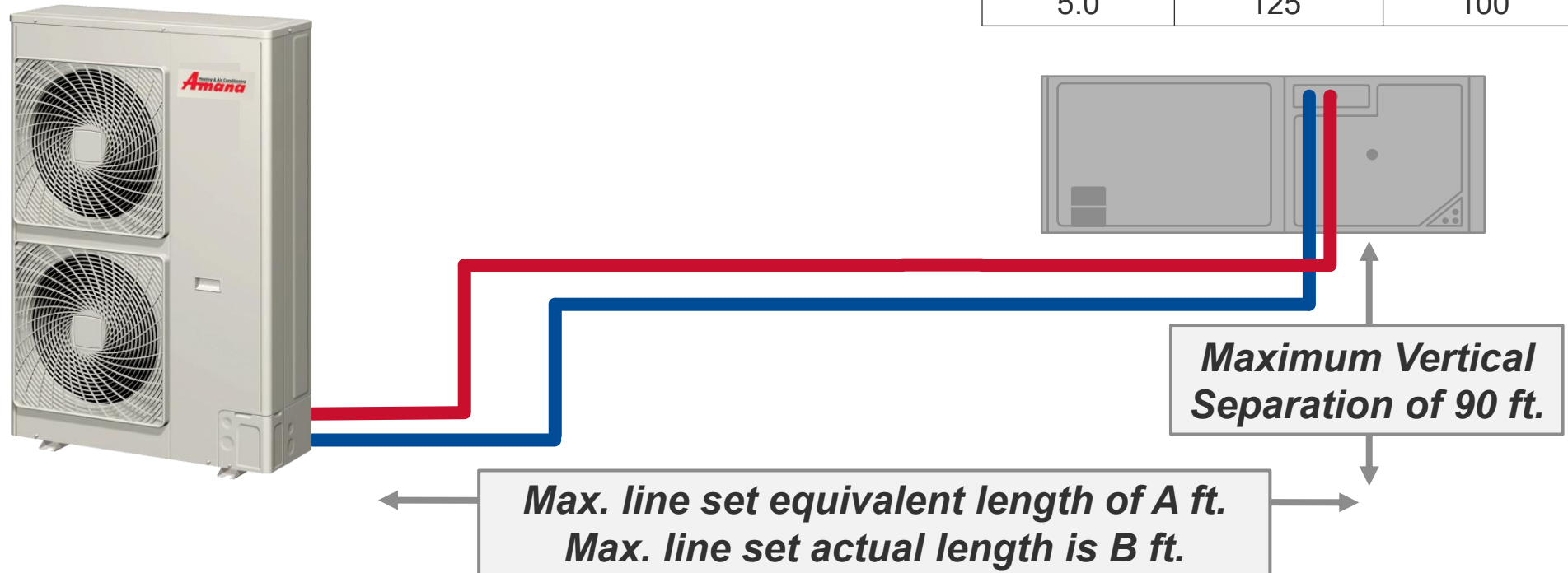

— Suction Line
— Liquid Line

Connecting Refrigerant Piping to Double Fan Models

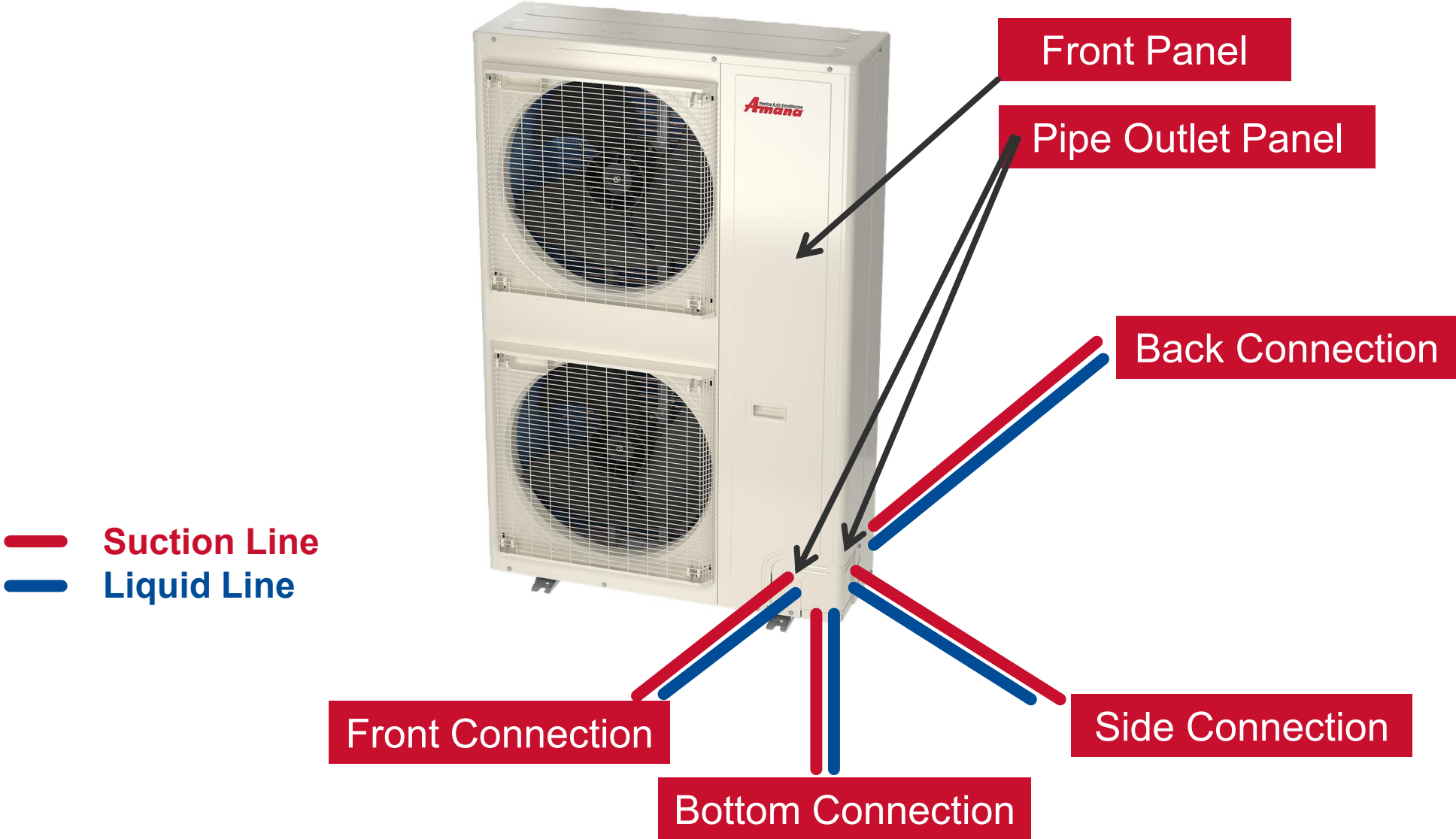

Connecting Refrigerant Piping to Double Fan Models

Back Connection (Recommended)

- Knock out the back connection knockout hole
 - After knocking out the knockout hole, it is recommended to apply repair paint to the edge and the surrounding surfaces to prevent rust.
- Connection from the stop valves to the field piping can be done by using the supplied Field connection piping kit.
- Ensure that the field connection piping does not come in contact with other piping, bottom frame or side panels of the unit.

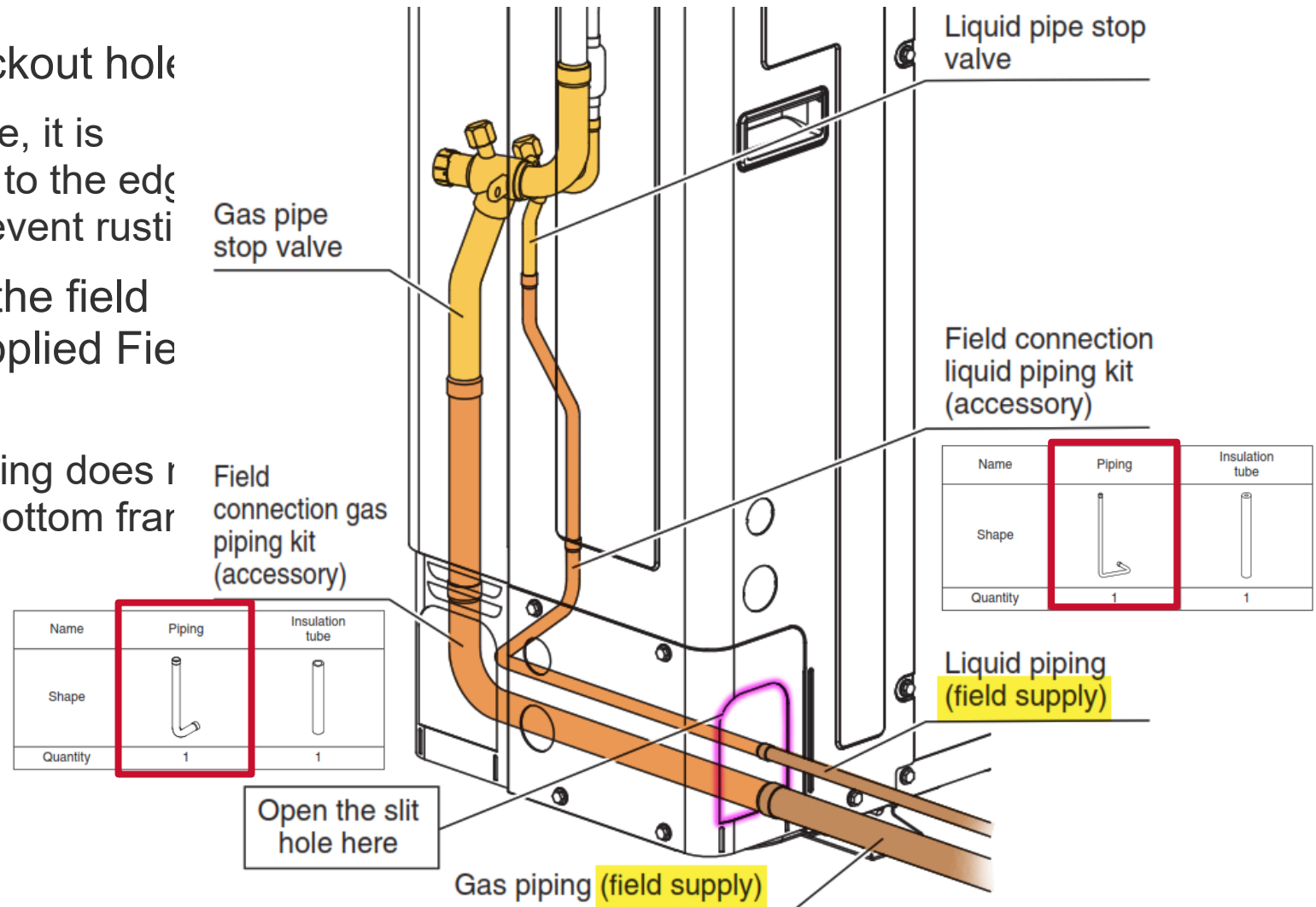

Connecting Refrigerant Piping to Double Fan Models (con't)

Back Connection (Recommended)

- Insulate the Liquid and Gas piping using the supplied insulation.
 - Supplied Gas Line insulation will not reach to the stop valve and must be completed with field supplied insulation.
- After piping work is complete seal the knockout hole with field supplied putty.

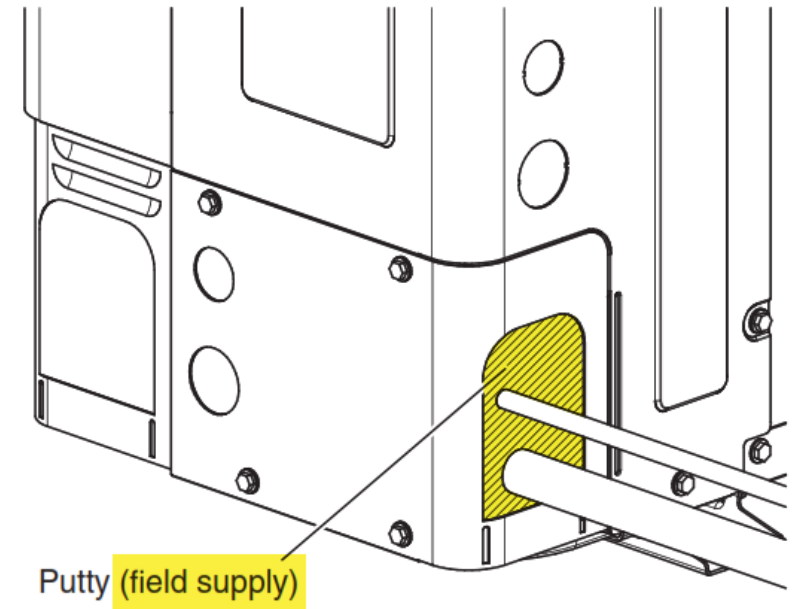
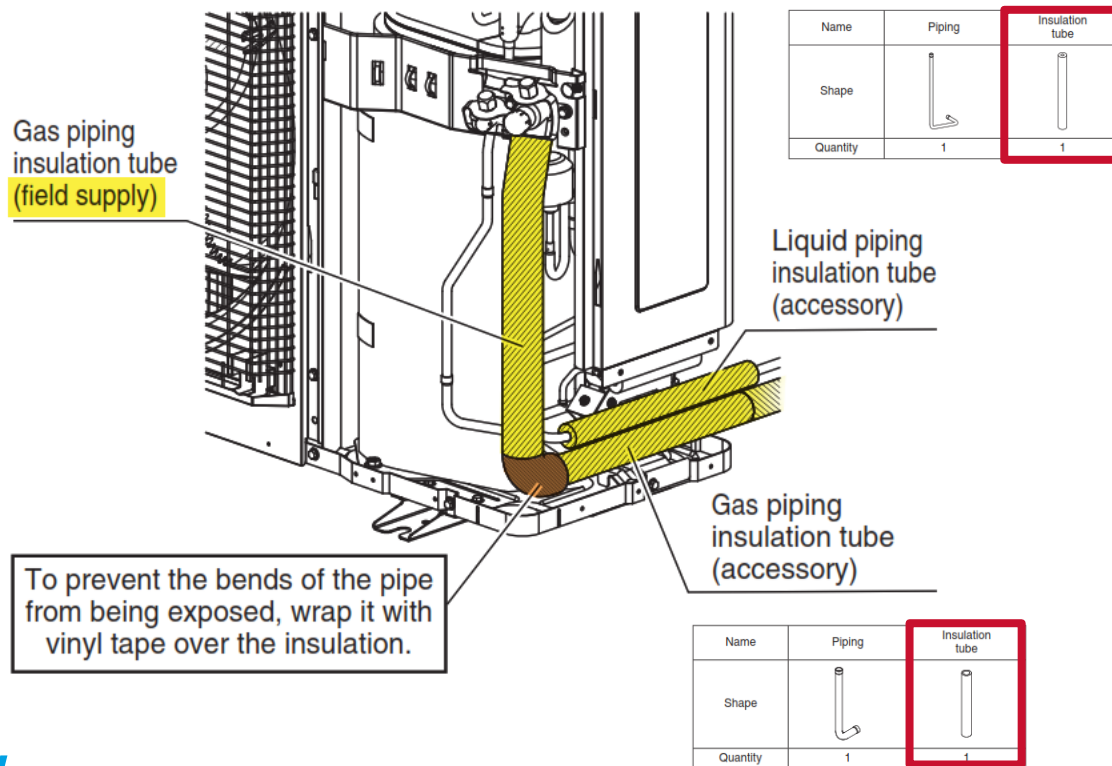

Connecting Refrigerant Piping to Double Fan Models

- Remove the valve cover and make sure that the stop valves are fully closed.
- Be careful when removing pinched piping, piping may be under pressure.
- Cut off the lower part of the smaller pinched piping just above the brazing point or mark with an appropriate tool such as pipe cutters.

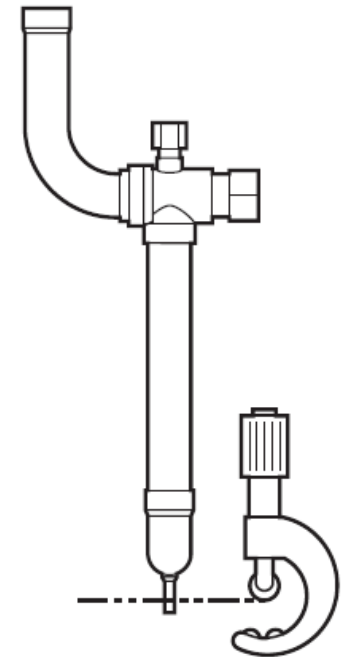
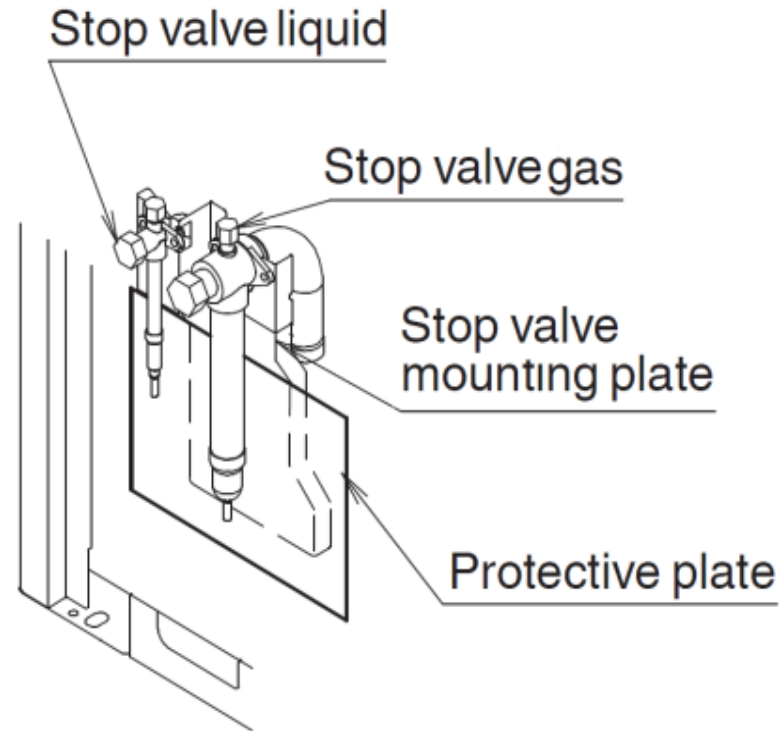
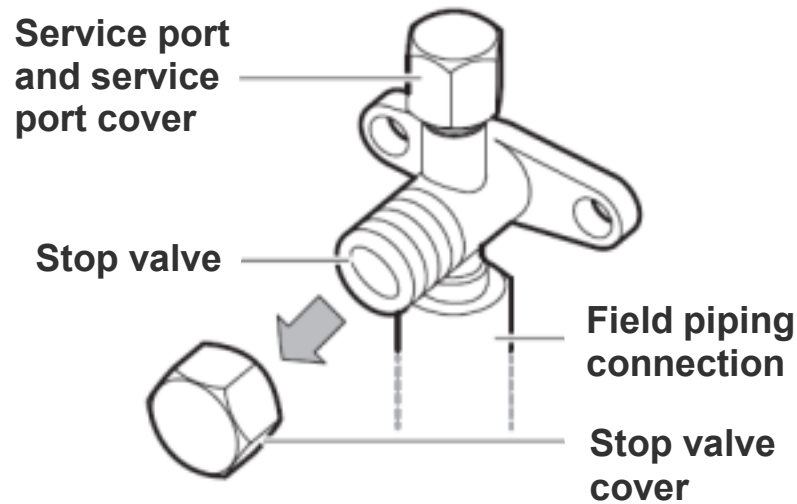

Preparation For Brazing

- REMOVE Schrader cores from service valves before brazing tubes to the valves.
 - Use a brazing alloy of 2% minimum silver content, (15% preferred) and DO NOT use flux.
 - Wrap valves with a wet rag or heat gel to prevent damage to valve.
 - If the bi-flow filter drier paint is scratched or burned, corrosion may occur.

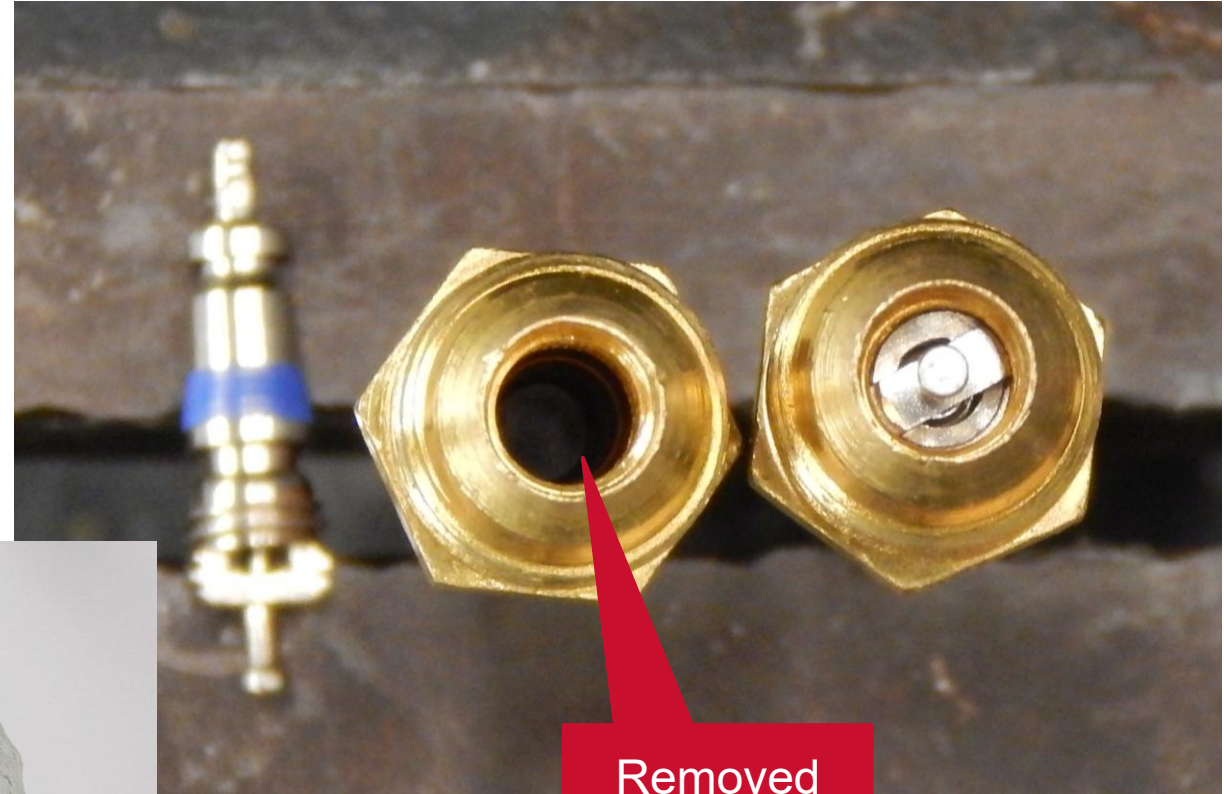

Removed
Schrader
Core

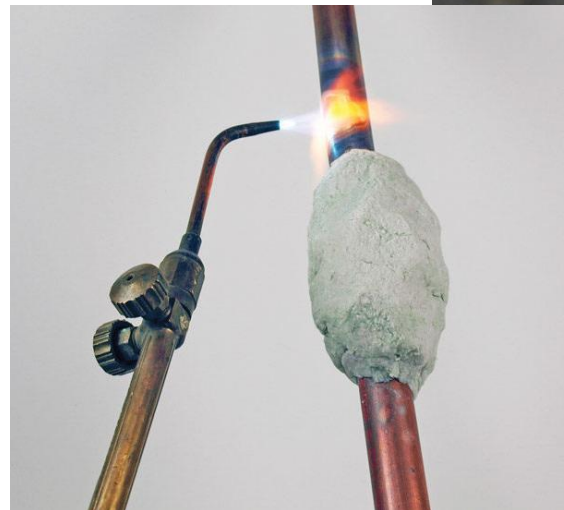

Brazing

Brazing With Nitrogen

- Dry nitrogen must be used during brazing to prevent oxidation formation.
 - Step 1: Leave opposite end of tubing open, so that nitrogen can exit during brazing.
 - Step 2: Set nitrogen regulator to 20 psig. to purge the line set for 15-30 seconds.
 - Step 3: Set nitrogen regulator between 1.5 to 3.0 psig. and sweep refrigerant lines while brazing.
 - Step 4: After brazing, quench the joints with water or a wet cloth to prevent overheating of the service valve and filter drier.



System Evacuation

- Some pumps come with 3/8- or 1/2-inch hose connections on the pump.
- By connecting larger vacuum rated hoses and removing the Schrader cores, evacuation will be faster and more complete.
- Attach a micron gauge to the port on the core remover.
 - With this connection, there is no need for a manifold.

REMOVE Schrader cores from service valves before evacuating

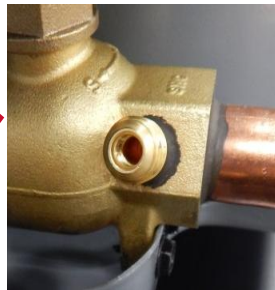

Voltage separation requirements



- Voltage separation is a requirement per UL 1995.
- **High Voltage:** Main power, compressor and fan power, power to sub boards, and power conditioners.
- **Low voltage:** All sensors, communication cables including thermostat cable.
- Maintaining wire routing after servicing any inverter air conditioner is very important.

Note: Before contacting the inverter board, power down the unit and verify that the measurement is between C+ C- in 50 vdc or less.

Low
Voltage

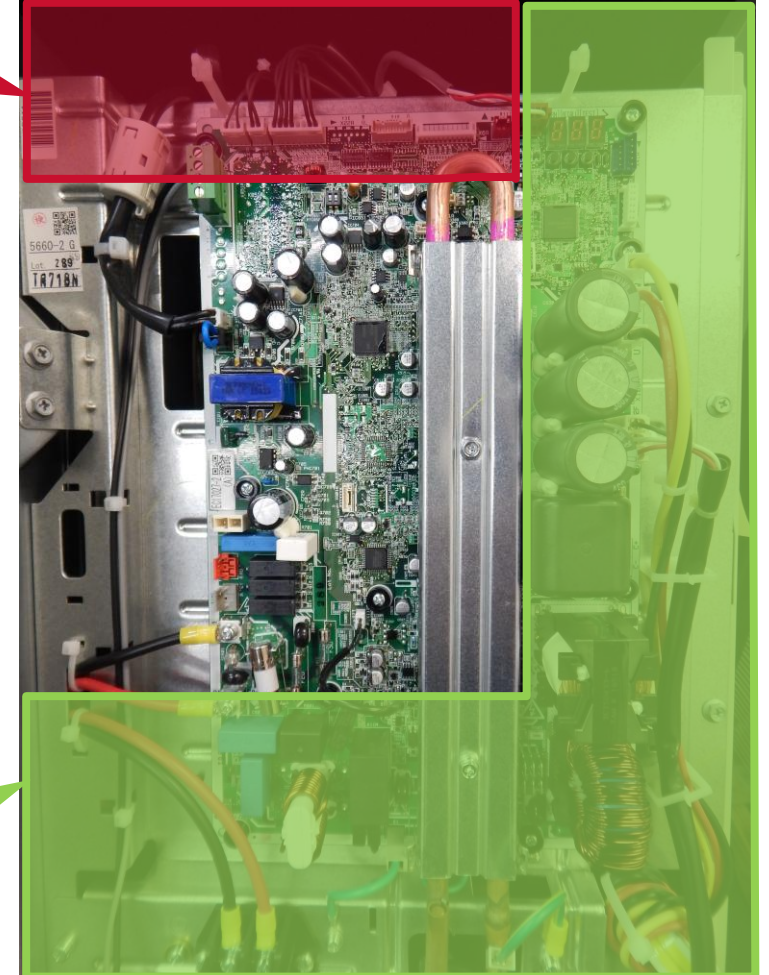

High
Voltage

PCB Small Chassis

Main PCB

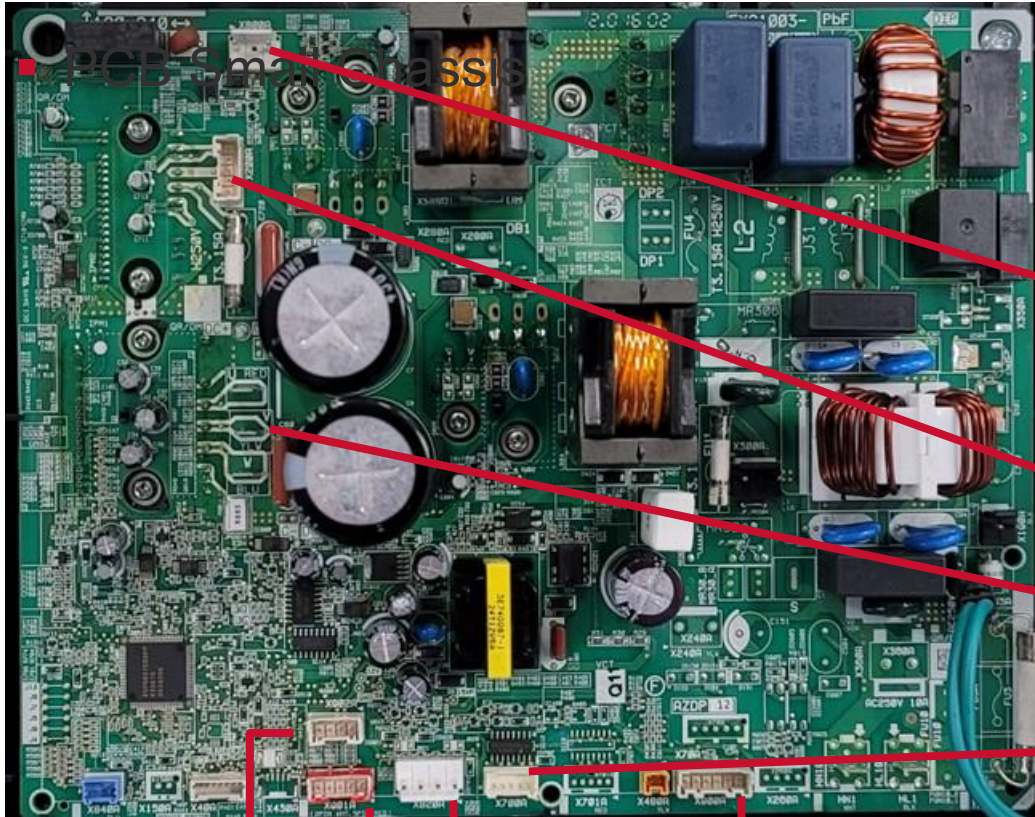

Solenoid coil
(Heat pump)



Condenser fan

Compressor
(U,V,W)

OD EEV

Pressure
sensor(low)

Ambient
thermistor

Defrost and coil
thermistor

Pressure
switch(high)

Discharge, liquid, and
suction thermistor

Service PCB

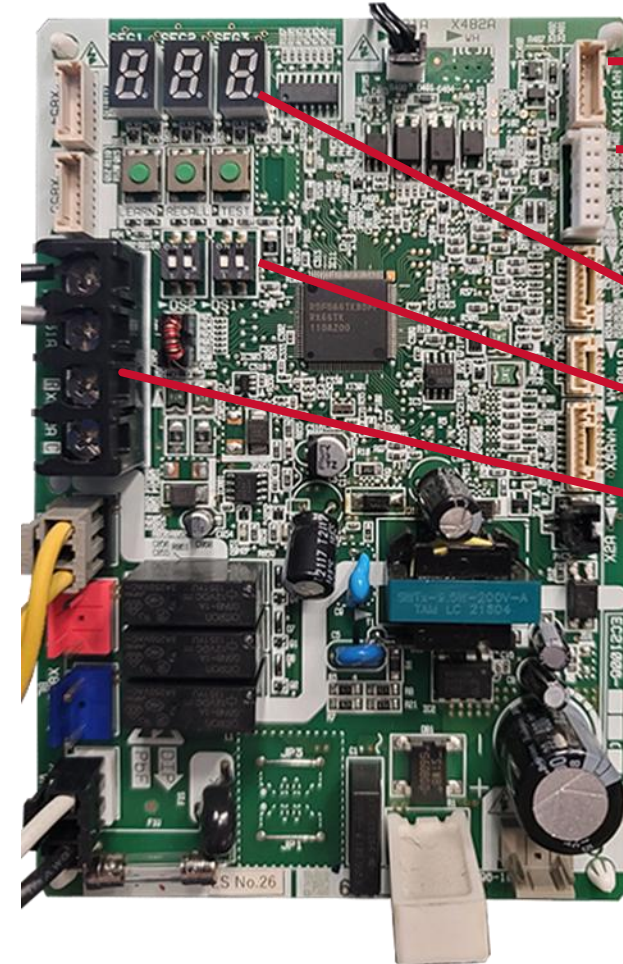

D-Checker
port

Shared data
port

7 Segment
Display

DS2/DS1

Data
connection

Smaller chassis models (1.5 - 3Ton) utilize a heat sink behind PCB.

PCB Large Chassis

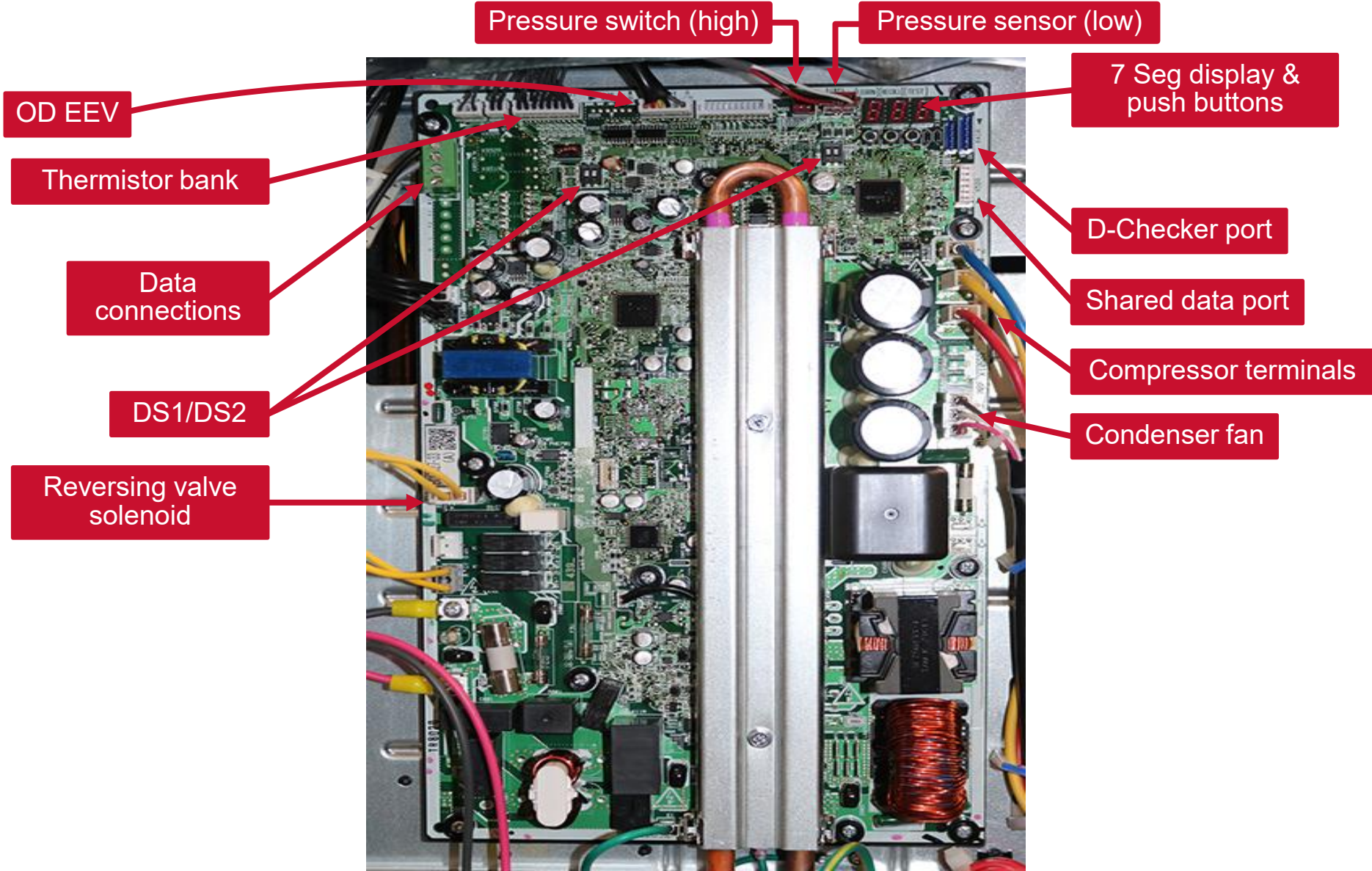

Voltage Monitor and Surge Protection

- Highly recommend the use of a voltage monitor and surge protection to protect the equipment from any voltage fluctuations or electrical surges.
 - Warranty does not cover unit damage or failure of the unit starting up due to interruption or insufficient electrical service.

Unit Type	Unit Supply Voltage (VAC)		
	Voltage	MIN	MAX
EEV Air Handler, Modular Blower	208/230	197	253
EEV Air Handler, Gas Furnace	115	103	126
EEV Cased Coil	24	22.6	25.5
Outdoor Unit	208/230	197	253



High Voltage Wiring

- The unit rating plate lists pertinent electrical data necessary for proper electrical service and overcurrent protection.
- Wires should be sized to limit the voltage drop to 2% max. from the main breaker.
- DO NOT install the switch on the unit.
 - Local codes often require a disconnect switch located near the unit.

Note: 3.5-5-ton has an optional knockout to route the high voltage wiring.



DAIKIN COMFORT TECHNOLOGIES MANUFACTURING, L.P.
 19001 KERMIER RD, WALLER, TX 77484

HEAT PUMP (OUTDOOR SECTION)

MODEL **AC6VSA2410AA**
 SERIAL NUMBER **0000000000**
 MFG. DATE **2024.7**
 NET WEIGHT **137 LBS. 62.0 KG**
 POWER SUPPLY **1~208/230V 60 HZ**



MAX OVERCURRENT PROTECTIVE DEVICE	25 A	MAXIMUM ALLOWABLE PRESURE	604 psig 4.17 MPa
MINIMUM CIRCUIT AMPACITY	22.4 A	AIR TIGHT TEST PRESSURE	604 psig 4.17 MPa
FAN MOTOR	OUTPUT 0.20 HP 0.15 kW	REFRIGERANT R32 (FACTORY CHARGED)	83 oz 2.34 kg
FAN/COMPRESSOR INVERTER DRIVE UNIT	17.60 A	PROTECTION	IPX4

**** INVERTER/CONTROLLER LIMITED TO LESS THAN 1 AMP
 SCCR kA RMS. SYMMETRICAL @600V MAX: 5**



Unitary Small HP
 AHRI Standard 210/240
Certification applies only when the complete system is listed with AHRI.

CONFORMS TO ANSI/UL
 STD. 60335-1 & 60335-2-40,
 CERTIFIED TO CSA STD.
 C22.2 NO.60335-1 &
 60335-2-40

Intertek
 5004994

ELECTRICAL CHARACTERISTICS ARE ONLY FOR OUTDOOR UNIT
 SUITABLE FOR OUTDOOR USE

ASSEMBLED IN THE USA

2P697228-13

High Voltage Wiring

Minimum Circuit Ampacity Maximum Overcurrent Protection Charts in I/O

- When using residual current operated circuit breakers, be sure to use a high-speed type (0.1 seconds or less) 200mA rated residual operating current.
- Use copper conductors only, and insulated power wiring.
- Select the power supply cable type and size in accordance with local codes.

MODEL NAME	Phase and frequency	Voltage	MCA (Min. circuit amp.)	MOP (Max. overcurrent protective device)	Communication wire selection
AXV6S*181*	1 Phase 60Hz	208/230V	12.8 A	15 A	18 AWG (typical)
AXV6S*241*			16.8 A	20 A	
AXV6S*301*			22.4 A	25 A	
AXV6S*361*			22.4 A	25 A	
AXV6S*421*			31.8 A	35 A	
AXV6S*481*			31.8 A	35 A	
AXV6S*601*			37.5 A	40 A	
AZV6S*181*	1 Phase 60Hz	208/230V	12.8 A	15 A	18 AWG (typical)
AZV6S*241*			16.8 A	20 A	
AZV6S*301*			22.4 A	25 A	
AZV6S*361*			22.4 A	25 A	
AZV6S*421*			31.8 A	35 A	
AZV6S*481*			31.8 A	35 A	
AZV6S*601*			37.5 A	40 A	
AZV7SA2410	1 Phase 60Hz	208/230V	22.4 A	25 A	18 AWG (typical)
AZV7SA3610			31.8 A	35 A	
AZV7SA4210			37.5 A	40 A	
AZV7SA4810			37.5 A	40 A	
AXV9SA2410	1 Phase 60Hz	208/230V	22.4 A	25 A	18 AWG (typical)
AXV9SA3610			31.8 A	35 A	
AXV9SA4810			37.5 A	40 A	

High Voltage Wiring

- Route power supply and ground wires through the high voltage port and terminate in accordance with the wiring diagram.
- Connect 208/230V/60Hz field wiring to the terminal block located in electrical panel.



**Terminal Block
1.5 - 3.0 Ton Units**

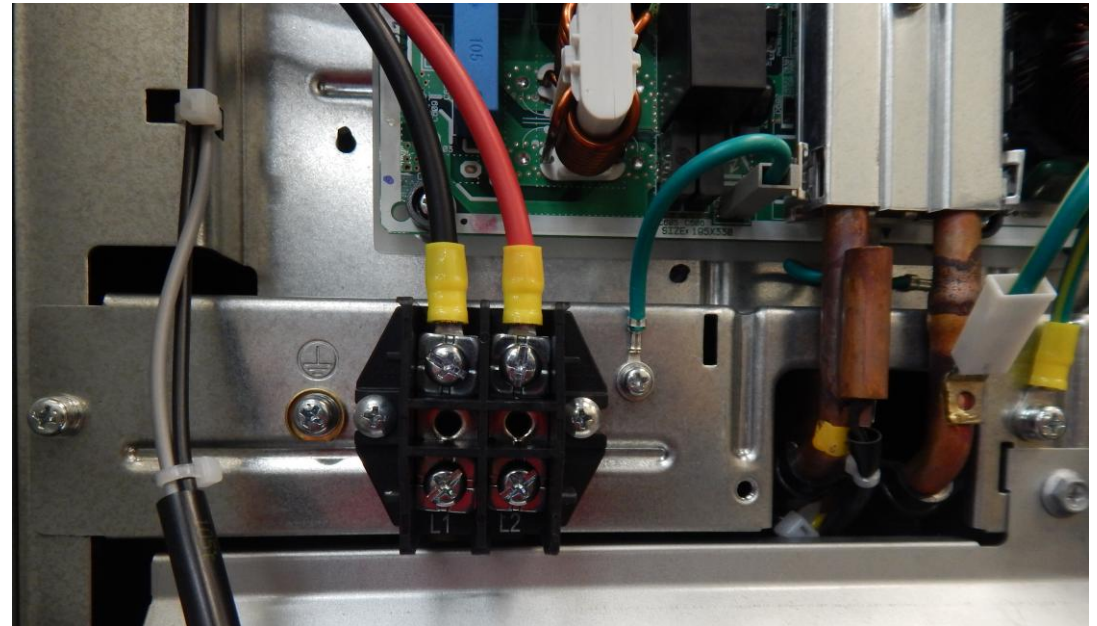

**Terminal Block
3.5 - 5.0 Ton Units**

Electrical Wiring Double Fan Models

- Route power supply and ground wires through the high voltage port and terminate in accordance with the wiring diagram.
 - Connect 208/230V/60Hz field wiring to the terminal block located in electrical panel.
- Route control wires through the low voltage port and terminate in accordance with the wiring diagram.

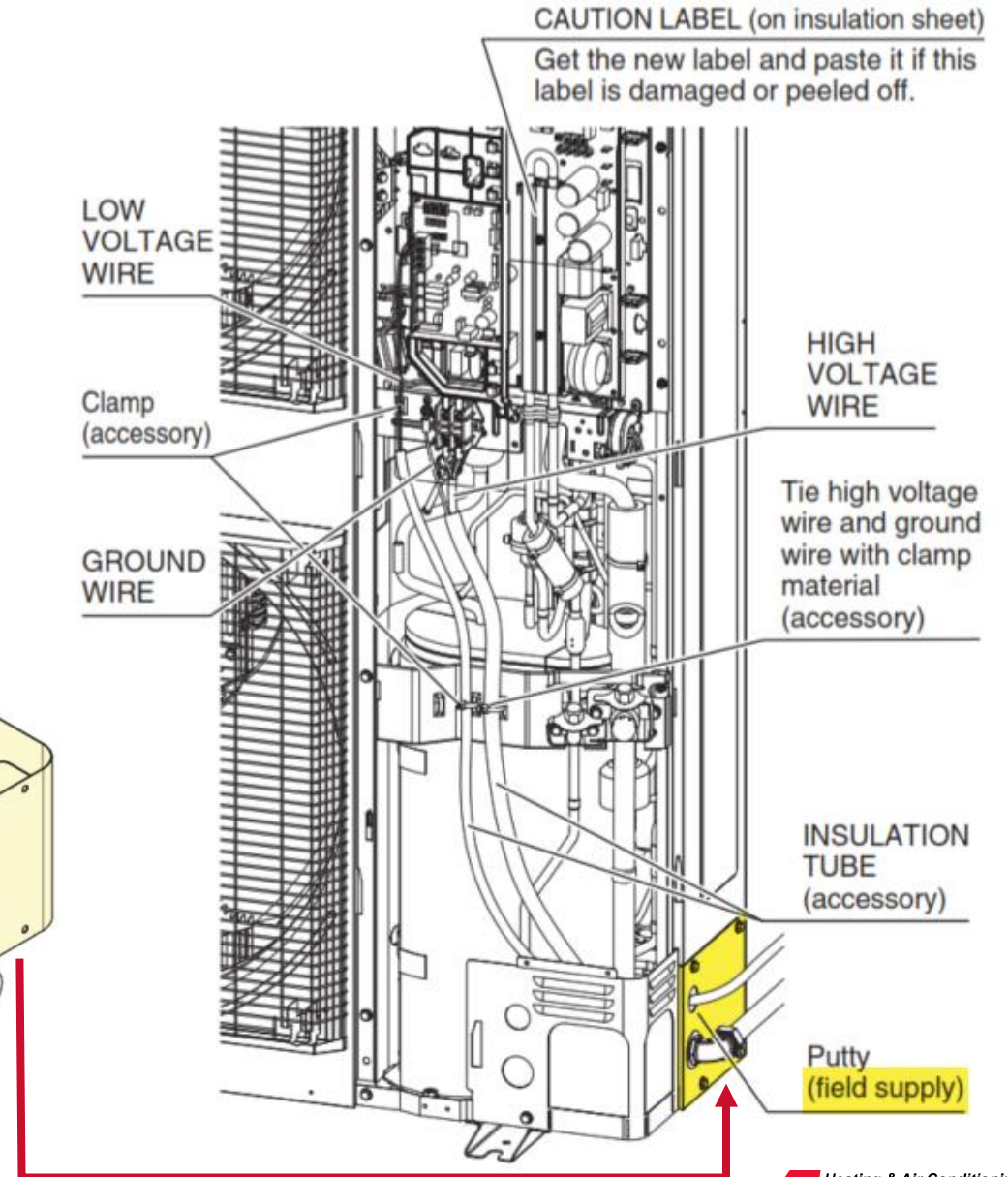
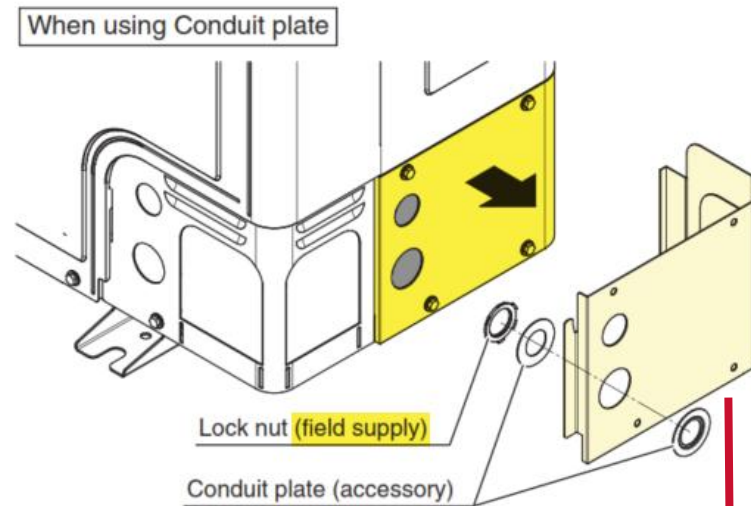

- The Amana Smart Thermostat are the approved thermostats for the Amana S system.

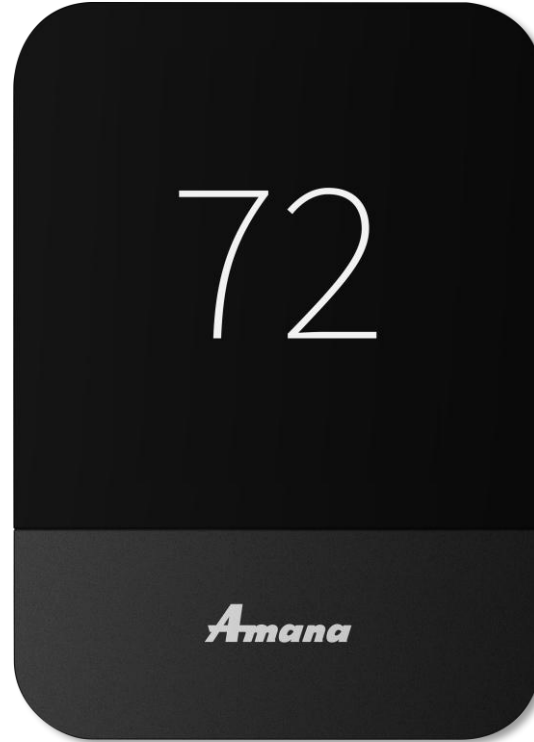

Low Voltage Wiring

Communicating Wiring Detail

- If low voltage requirements are not met:
 - Check/eliminate wiring connections
 - Crossed wires, loose bent, broken wires, etc.
 - Replace wiring
 - 18 AWG stranded is recommended
 - Move DS1 switches on outdoor PCB to the opposite position.

Amana Smart Thermostat

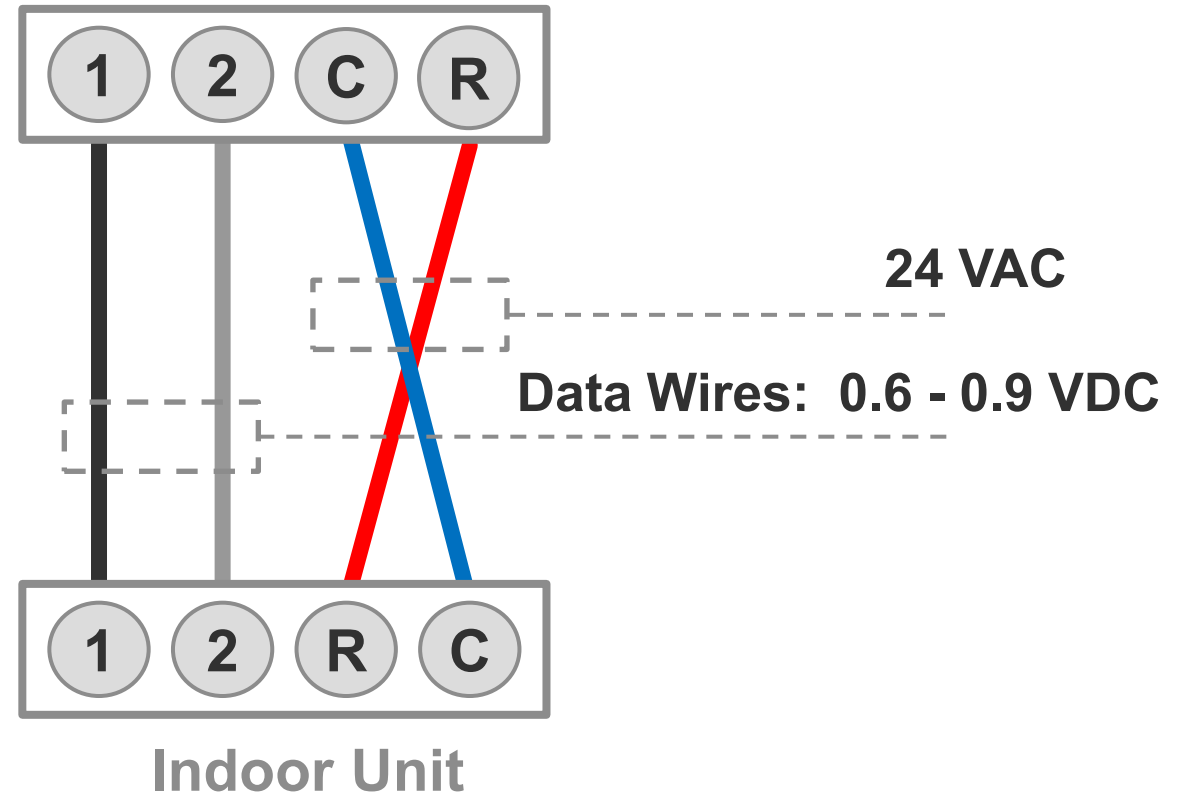

Wiring Detail When Paired With an Air Handler

- Minimum 18 AWG.
- Max 125' between communicating thermostat and indoor units.
- Max 250' between outdoor and indoor units.
- Four wires from indoor unit and coil PCB to thermostat.
- Two wires to outdoor unit.

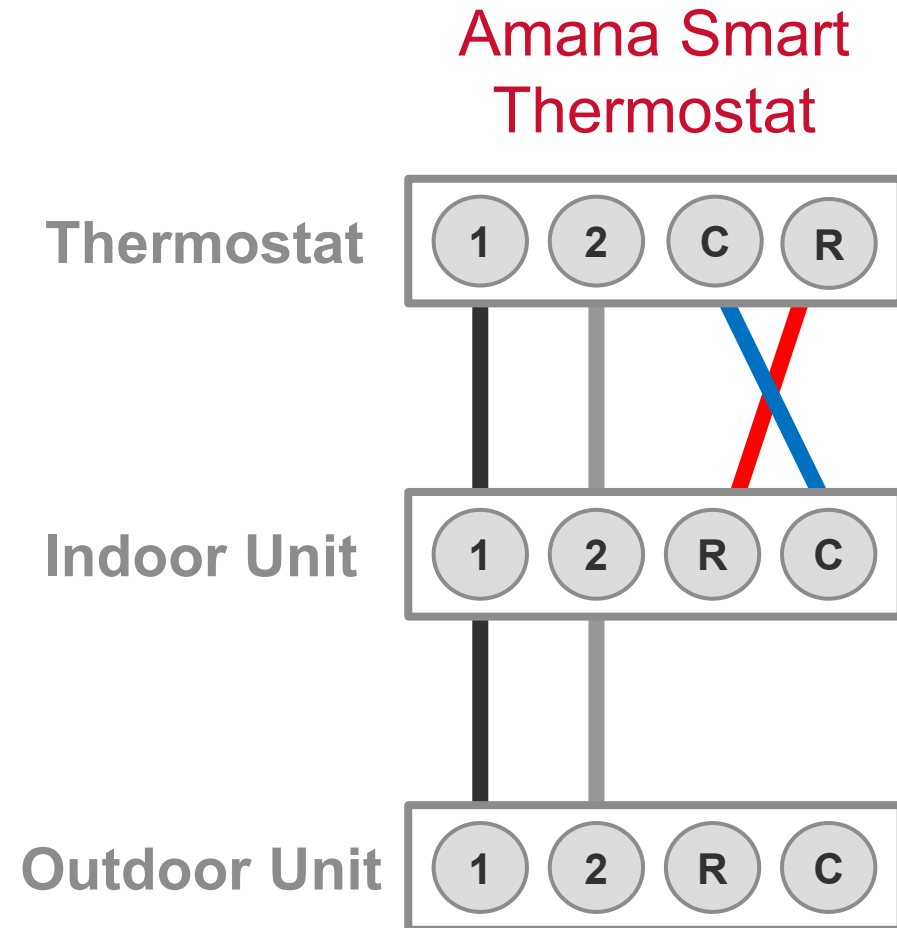

Low Voltage Wiring Non-A2L furnace

- The leak detection sensor must be wired directly to the Non-A2L Furnace Integration Kit and installed as a pass-through to the non-A2L furnace control board.

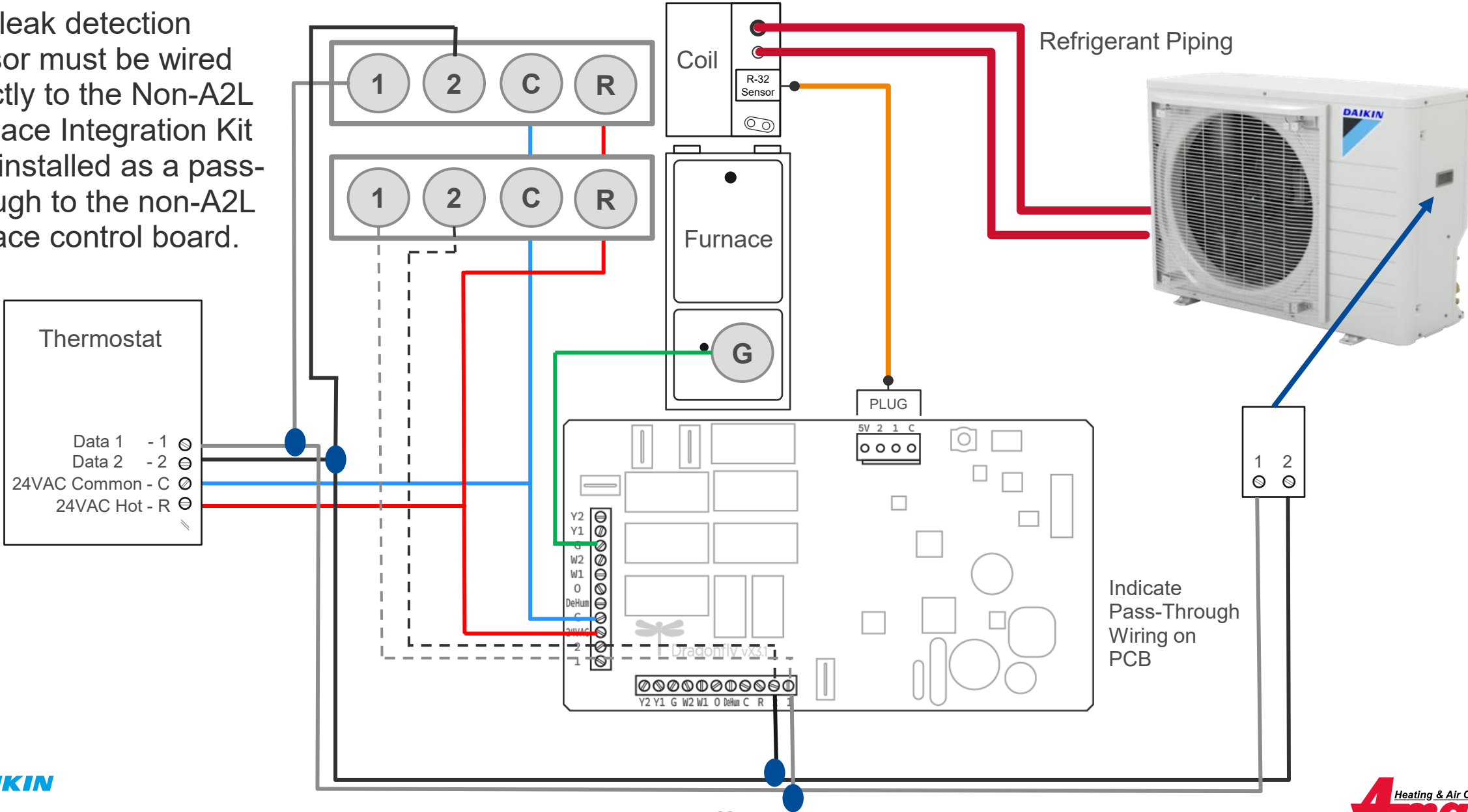

EWC UT-3000 Zone Control



- The UT-3000 controls up to three zones (single board).
 - Up to five zones (twinned) using 24V power open/close motorized dampers.
- EWC Zoning complies with Manual Zr (ANSI/ACCA 11 Manual Zr – 2018)
- When paired with EWC you must set lockout temperatures from the UT-3000 Zone Control Board menus.
- You must set Zone Weights from the UT-3000 Zone Control. Default Settings are as follows:
 - 3 Zone: 70% / 15% / 15%
 - 2 Zone: 60% / 40%

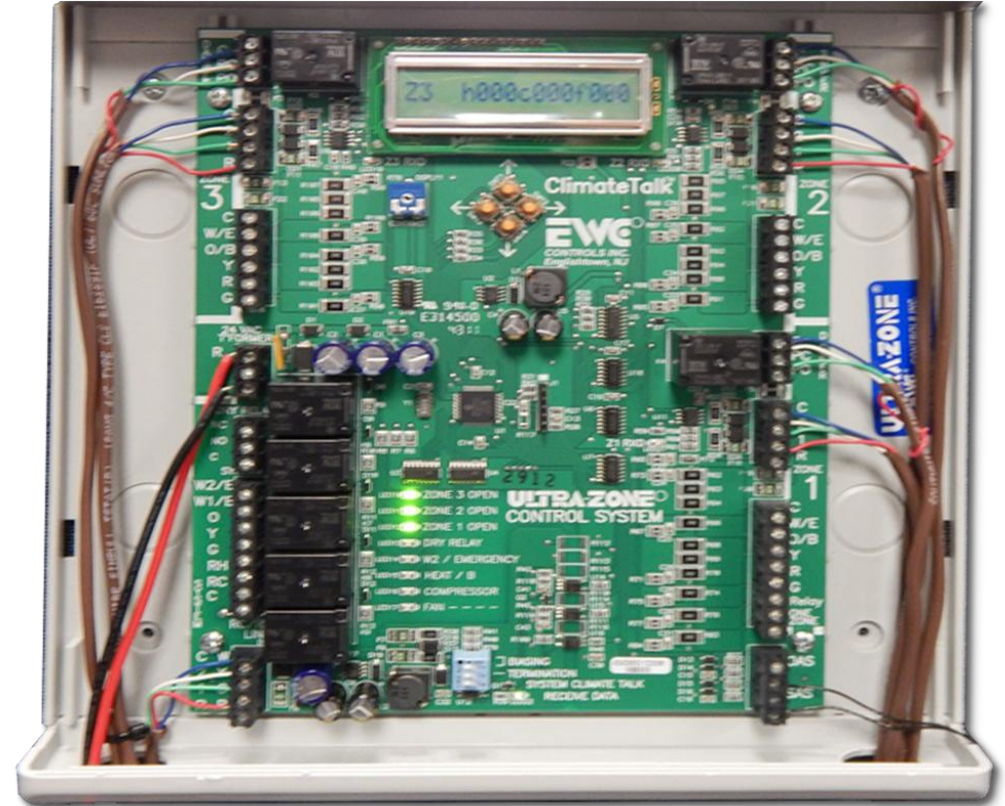

Copyright EWC Controls, Inc. 02/09/2012

Communicating Thermostats In All Zones

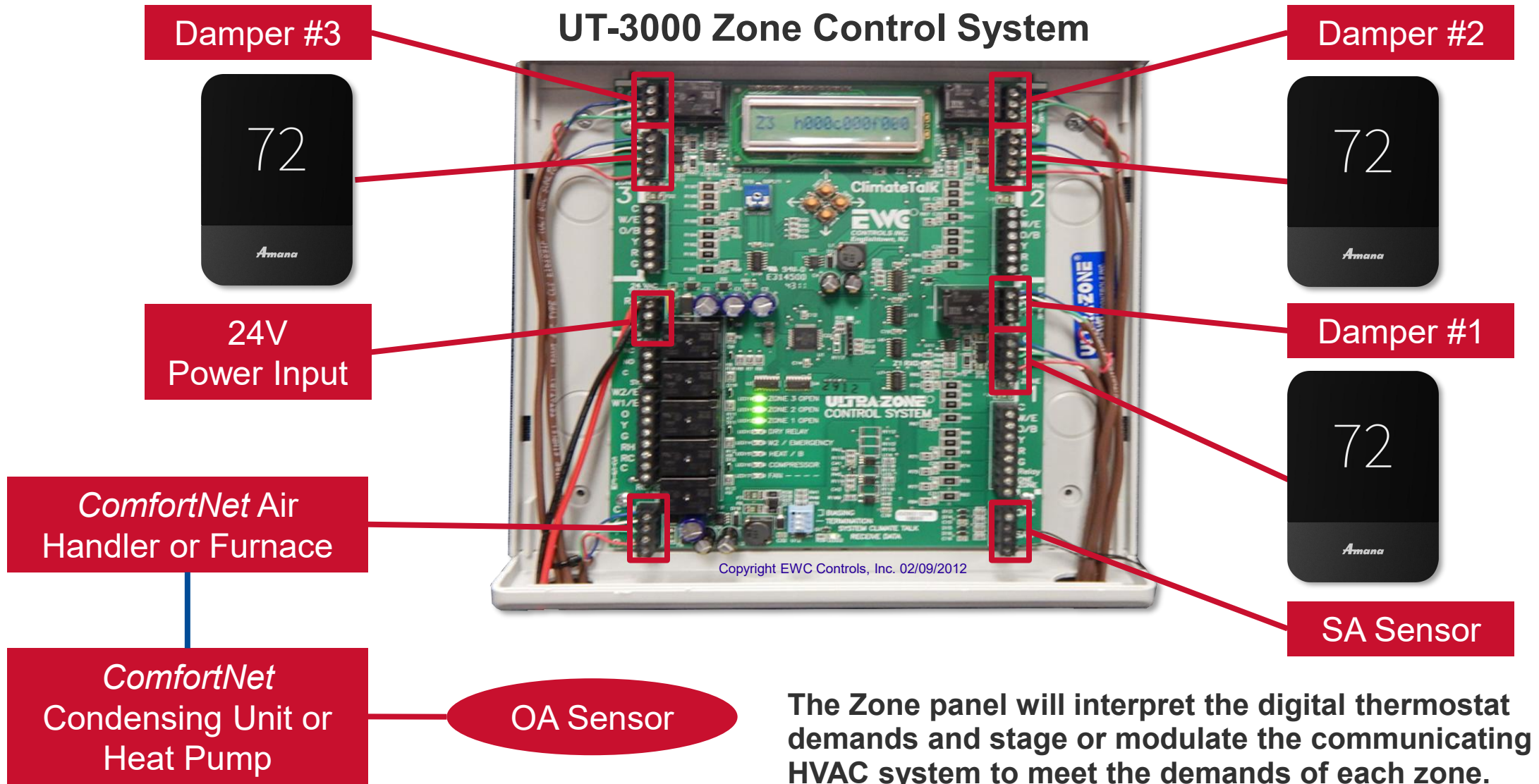

EWC UT-3000 Zone Control + New Distributed Air Pressure Controller (DAPC)

- The DAPC module can monitor the system static pressure and send the UT-3000 “Open & Close” damper commands.
- When the static pressure gets too high, the DAPC will modulate the closed zone dampers towards the open position to control the static pressure.
- DAPC’s default static pressure set-point (0.5”wc)
 - Static pressure set-point can be adjusted from the DAPC module. (0.15”wc - 1.5”wc)
- Customize and let the DAPC discover the actual non-zoned static pressure of your system to adopt that value as the static pressure set-point.

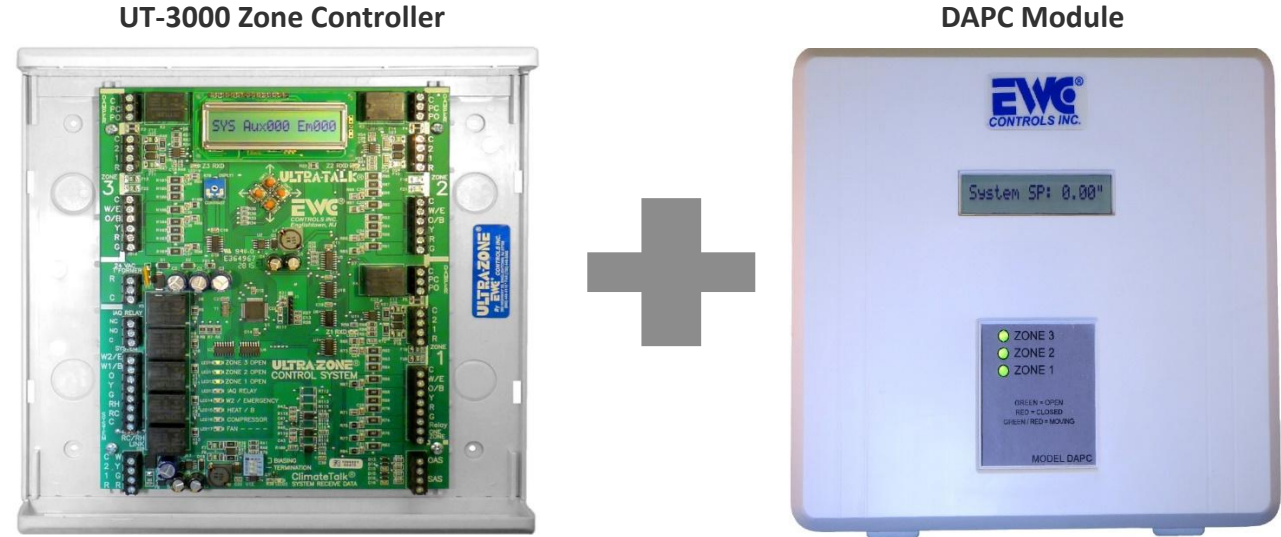

Add Equipment Zone Board (Zoning Mode & Circulation Selection)

- Zoning Mode will be automatically turned ON & Circulation Selection will be automatically turned OFF when adding an EWC Zone Board through Equipment setup- Add Equipment- Zone Board.
 - Zoning Mode allows the system to run with lower indoor airflow compared to normal operation when the cooling or heating demand is low.
 - Circulation Selection can be turned ON and OFF to avoid automatically increasing the indoor CFM by circulation control
 - When ON the system may increase indoor CFM to circulate indoor air when the outdoor control detects a low evaporative temperature.
 - When OFF the indoor CFM will not increase even if the outdoor detects a low evaporative temperature. This is recommended for zoning applications.

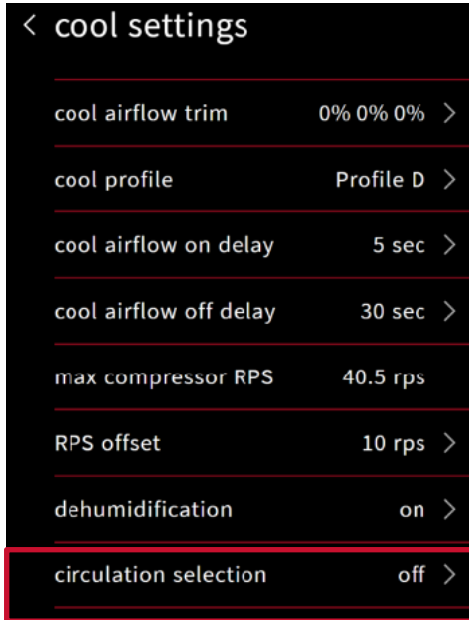
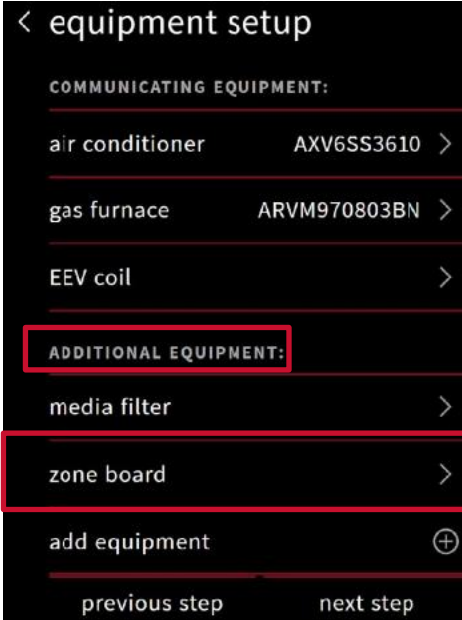
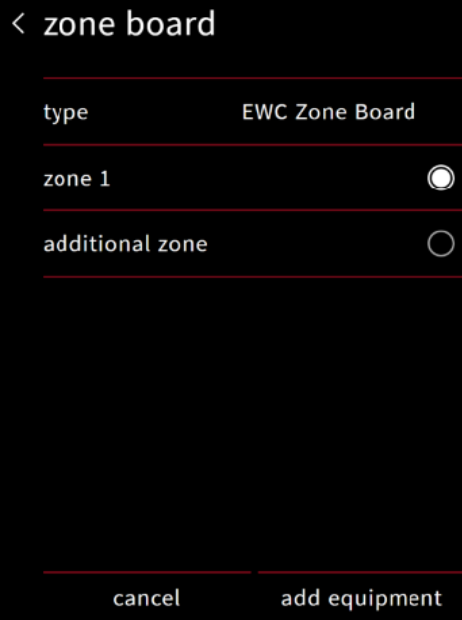
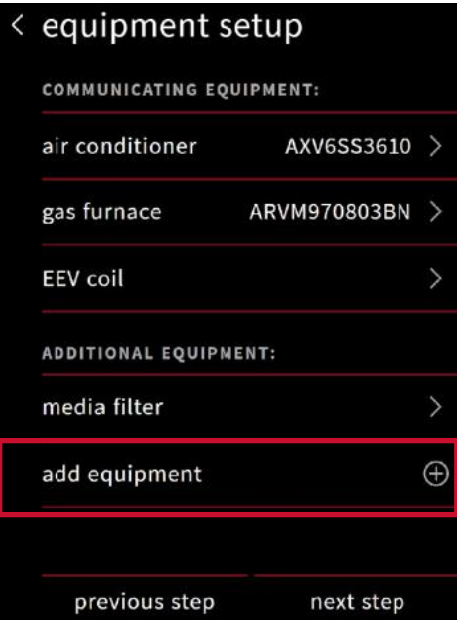

Zoning control accessory board

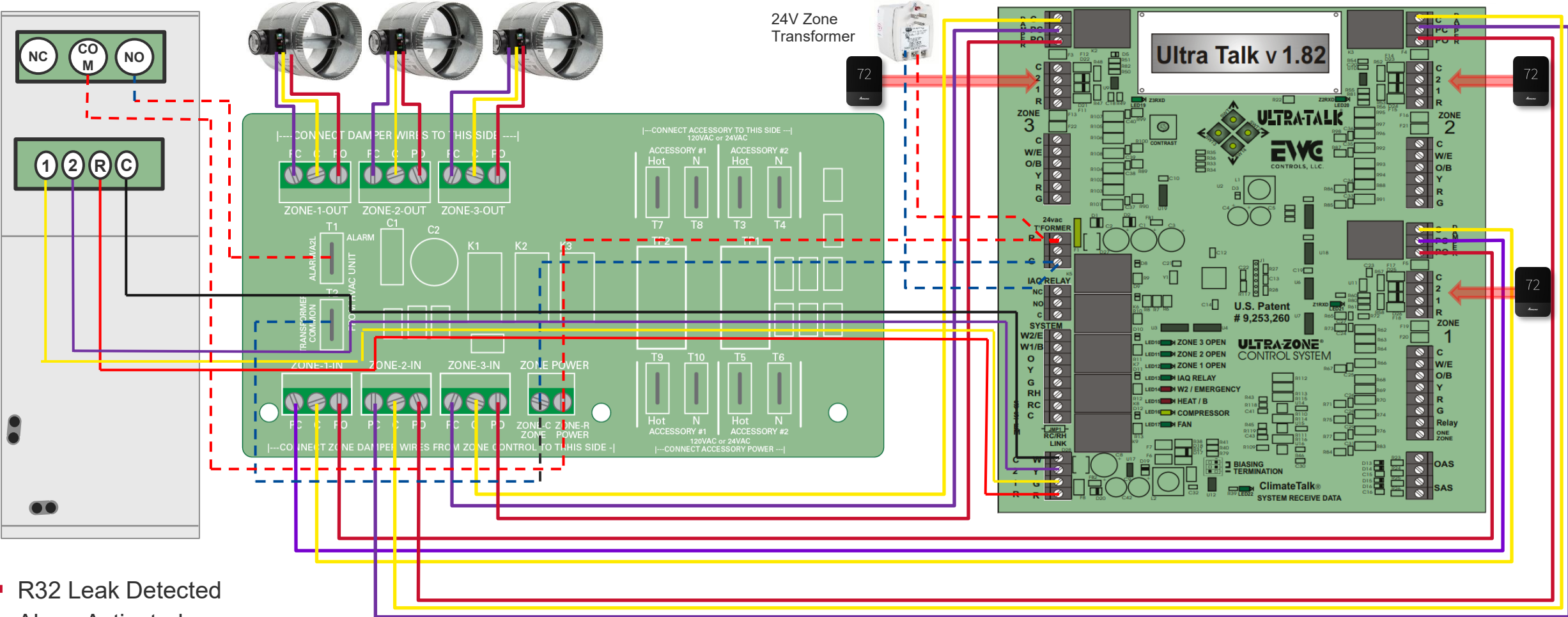

- R32 Leak Detected
- Alarm Activated
- All Relays on Zone Mitigation Board switch
- Signals coming from Zoning Board to control dampers are disconnected from dampers
- 24VAC from Zone Transformer is applied to Power Open (PO) outgoing terminals

- All Dampers open and remain powered open
- Mitigation Mode Ends, Relays switch back and zoning board can control dampers directly again





Calculate Refrigerant Charge

- The outdoor unit is shipped with a predetermined factory charge level.
- The installer **MUST** measure the new or existing line set length and diameter for the best charging calculation.
- Charging tables are provided in the I/O based on indoor coil and line set length and diameter.

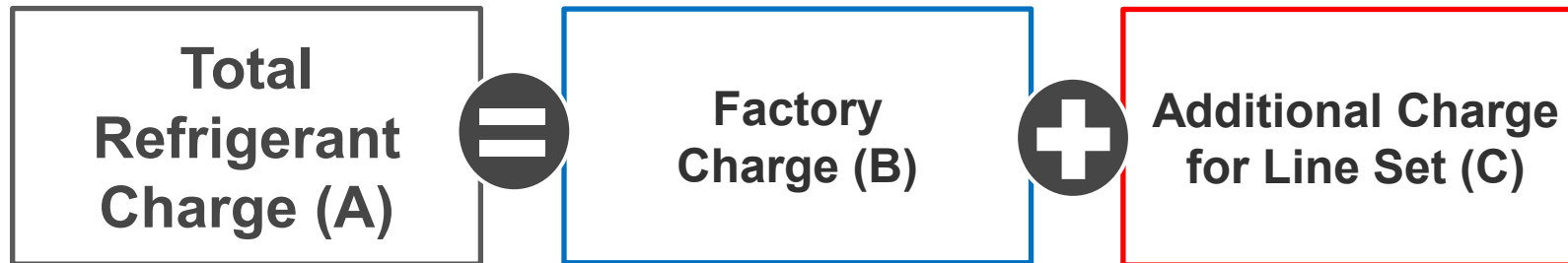

Note: Beyond your calculated charge, not more than 0.5lb. (8 oz.) of refrigerant must be added to the system to achieve the target sub-cooling. It is recommended to add 1 oz. refrigerant each time and let the system stabilize for 10 minutes.

Single Fan Models Charge table

Charge Table for Total Refrigerant (A)

AC/HP	Total/Additional refrigerant (oz.)																							
	1.5 ton S-series										2.0 ton S-series													
Indoor Unit type	CAPEA, CHPEA, AHVE																							
Liquid Pipe Diameter(inch)	1/4"				5/16"				3/8"				5/16"				3/8"							
Suction Pipe Diameter(inch)	5/8"		3/4"		5/8"		3/4"		5/8"		3/4"		5/8"		3/4"		5/8"		3/4"					
Actual Line Set Length(ft.)	(A)	(C)	(A)	(C)	(A)	(C)	(A)	(C)	(A)	(C)	(A)	(C)	(A)	(C)	(A)	(C)	(A)	(C)	(A)	(C)				
15 or less	n/a		n/a		n/a		n/a		73*	0	73	0	n/a				n/a		73*	0	73	0		
20	n/a		74*	1	n/a		75	2	76	3	76	3	n/a				75	2	76	3	76	3		
25	n/a		75	2	76	3	77	4	78	5	78	5	76	3	77	4	78	5	78	5	78	5		
30	76*	3	77	4	78	5	80	7	81	8	83	10	78	5	80	7	81	8	83	10	83	10		
35	77*	4	78	5	80	7	82	9	83	10	87	14	80	7	82	9	83	10	87	14	87	14		
40	79	6	79	6	82	9	84	11	86	13	90	17	82	9	84	11	86	13	90	17	90	17		
45	80	7	80	7	83	10	86	13	89	16	94	21	83	10	86	13	89	16	94	21	94	21		
50	81	8	82	9	85	12	89	16	91	18	97	24	85	12	89	16	91	18	97	24	97	24		
55	82	9	83	10	87	14	91	18	94	21	99	26	87	14	91	18	94	21	99	26	99	26		
60	83	10	84	11	89	16	93	20	96	23	102	29	89	16	93	20	96	23	102	29	102	29		
65	84	11	85	12	90	17	95	22	99	26	106	33	90	17	95	22	99	26	106	33	106	33		
70	85	12	87	14	92	19	98	25	102	29	109	36	92	19	98	25	102	29	109	36	109	36		
75	86	13	88	15	94	21	100	27	104	31	112	39	94*	21	100*	27	104	31	112	39	112	39		
80	88	15	89	16	96	23	102	29	107	34	115	42	n/a				107	34	115	42	115	42		
85	89	16	90	17	97	24	104	31	109	36	119	46					109	36	119	46	119	46	119	46
90	90	17	92	19	99	26	106	33	112	39	122	49					112	39	122	49	122	49	122	49
95	91	18	93	20	101	28	109	36	115	42	125	52					115	42	125	52	125	52	125	52
100	92	19	94	21	103	30	111	38	117	44	128	55					117	44	128	55	128	55	128	55

Factory Charge (B)
Standard Diameter
 (For replacement installation)

*: Offered in HP models only.





Calculate Refrigerant Charge

- The outdoor unit is shipped with a predetermined factory charge level.
- The installer **MUST** measure the new or existing line set length and diameter for the best charging calculation.
- Charging tables are provided in the I/O based on line set length and allowable line set diameter.

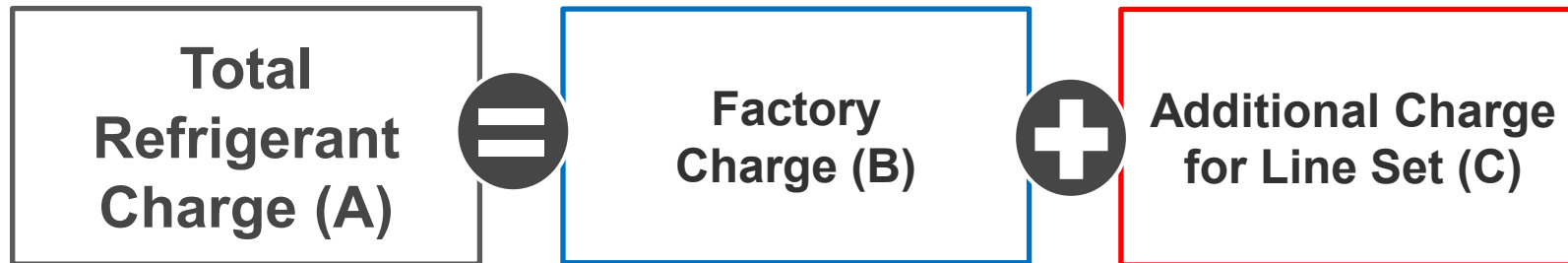

Note: Beyond your calculated charge, not more than 0.5lb. (8 oz.) of refrigerant must be added to the system to achieve the target sub-cooling. It is recommended to add 1 oz. refrigerant each time and let the system stabilize for 10 minutes.

Double Fan Models Charge Table

- Find the allowable line set combinations listed in the Installation Manual and verify line set selection based on tonnage of ODU.
- Go to charging chart in the Installation Manual and charge the system based on line set length and verified allowable line set diameter.

Cond Unit Tons	Allowable line set diameter					
	Liquid		Suction			
	5/16"	3/8"	5/8"	3/4"	7/8"	1-1/8"
2.0	X	X	X	X		
3.0	X	X		X	X	
5.0		X			X	X

Liquid Pipe Diameter(inch)	Total/Additional refrigerant (oz.)													
	5/16"						3/8"							
	5/8"		3/4"		7/8"		5/8"		3/4"		7/8"		1-1/8"	
Vapor Pipe Diameter(inch)	(A)	(C)	(A)	(C)	(A)	(C)	(A)	(C)	(A)	(C)	(A)	(C)	(A)	(C)
Actual Line Set Length(ft.)	(A)	(C)	(A)	(C)	(A)	(C)	(A)	(C)	(A)	(C)	(A)	(C)	(A)	(C)
15 or less	162	0	162	0	162	0	162	0	162	0	162	0	162	0
20	164	2	164	2	164	2	165	3	165	3	165	3	165	3
25	166	4	166	4	166	4	167	5	168	6	168	6	168	7
30	167	5	168	6	168	6	170	8	170	8	171	9	172	10
35	169	7	170	8	170	8	173	11	173	11	174	12	175	13
40	171	9	171	10	172	10	175	14	176	14	177	15	178	16
45	173	11	173	11	174	12	178	16	179	17	180	18	181	20
50	175	13	175	13	176	14	181	19	182	20	183	21	185	23
55	176	14	177	15	178	16	184	22	184	22	186	24	188	26
60	178	16	179	17	180	18	186	24	187	25	188	27	191	29
65	180	18	181	19	182	21	189	27	190	28	191	30	194	33
70	182	20	183	21	184	23	192	30	193	31	194	32	198	36
75	184	22	185	23	187	25	194	32	196	34	197	35	201	39
80	185	23	187	25	189	27	197	35	198	36	200	38	204	42
85	187	25	189	27	191	29	200	38	201	39	203	41	207	46
90	189	27	190	29	193	31	202	41	204	42	206	44	211	49
95	191	29	192	30	195	33	205	43	207	45	209	47	214	52
100	193	31	194	32	197	35	208	46	210	48	212	50	217	55
105	194	32	196	34	199	37	211	49	212	50	215	53	N/A	
110	196	34	198	36	201	39	213	51	215	53	218	56		
115	198	36	200	38	203	41	216	54	218	56	221	59		
120	200	38	202	40	205	43	219	57	221	59	224	62		
125	202	40	204	42	207	45	221	59	224	62	227	65		
130	203	41	206	44	209	47	224	62	226	64	230	68		
135	205	43	208	46	211	49	227	65	229	67	233	71		
140	207	45	209	48	213	51	229	68	232	70	236	74		
145	209	47	211	49	215	53	232	70	235	73	239	77		
150	211	49	213	51	217	55	235	73	238	76	242	80		

Factory Charge (B)

- Determine the following info using the I/O, assuming liquid line is 3/8" and suction line is 3/4". (All 90's are Long Radius in this example.)



AZV6SA241A

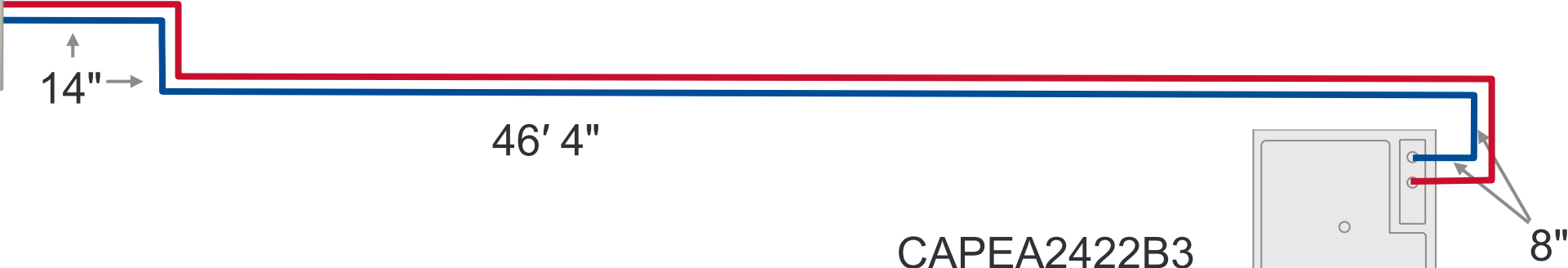

Line set total length 54' 2"

Line set vertical elevation 1' 10"

CAPEA2422B3

Factory charge 73 oz

Additional charge 26 oz

Total charge 99 oz

Target Subcooling 8°F

Type of Elbow Fitting	Inside Diameter		
	3/4"	7/8"	1-1/8"
90° Short Radius	1.7'	2'	2.3'
90° Long Radius	1.5'	1.7'	1.6'
45° Radius	0.7'	0.8'	1'



Agenda

Pre-Installation

Installation

Commissioning

- Start-up screen is displayed upon powering the thermostat.
- The welcome screen displays preferences to choose from.
- Version of the thermostat is displayed on the equipment type screen.
- Selecting setup options allows you to factory reset the thermostat.

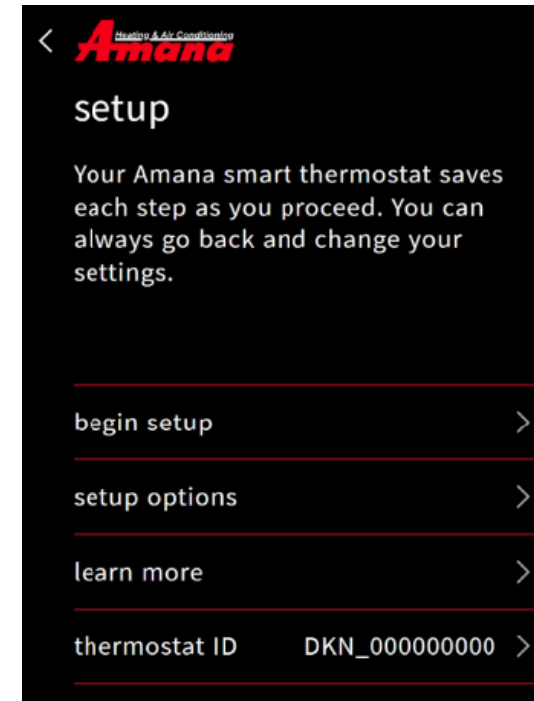
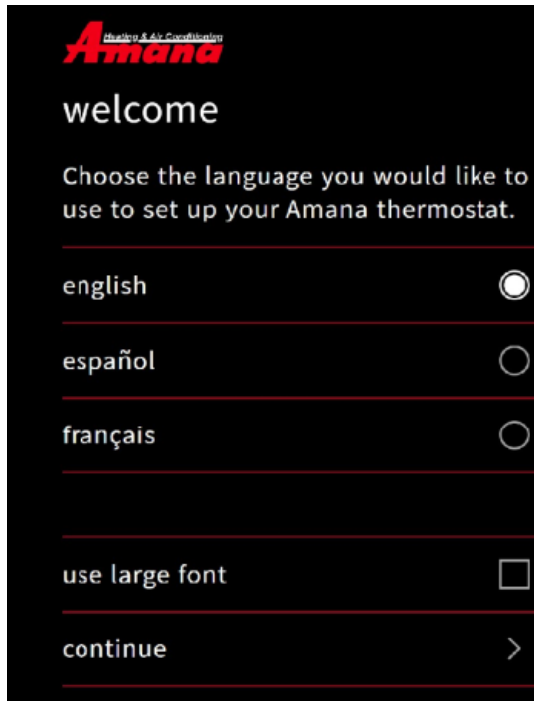

Commissioning

- Begin set-up walks installers through the entire commissioning process to ensure the system is configured properly and ready for the homeowner to use.
 - Enables random access to any setting.
 - Remembers settings as they are entered.
 - Individual may stop and restart as needed.
- The screens are populated based on the model numbers of the equipment, matched to a database of device configuration settings.

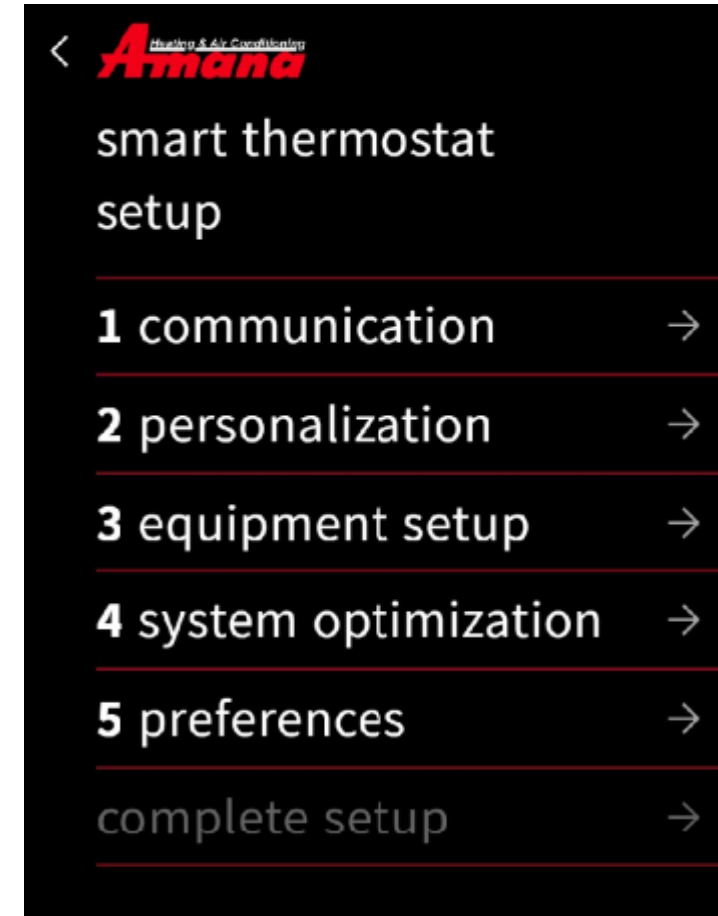
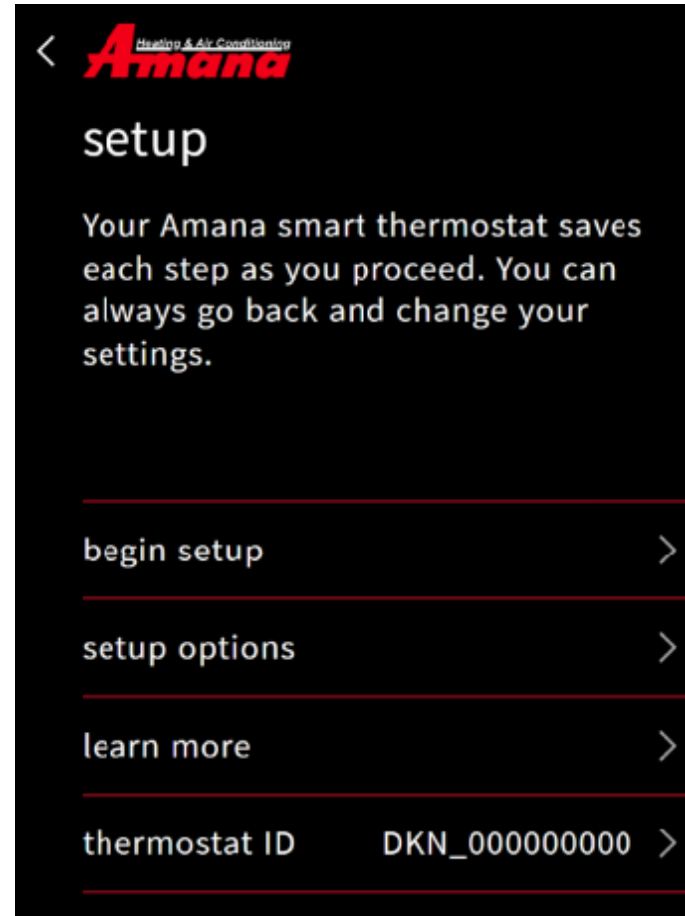



Start-up

- Tapping begin set-up starts the five step set-up process:
 - Communication
 - Personalization
 - Equipment Set-up
 - System Optimization
 - Preferences
- Note: All steps must be completed and reviewed before completing set-up to ensure the system is configured properly and ready for the homeowner to use.

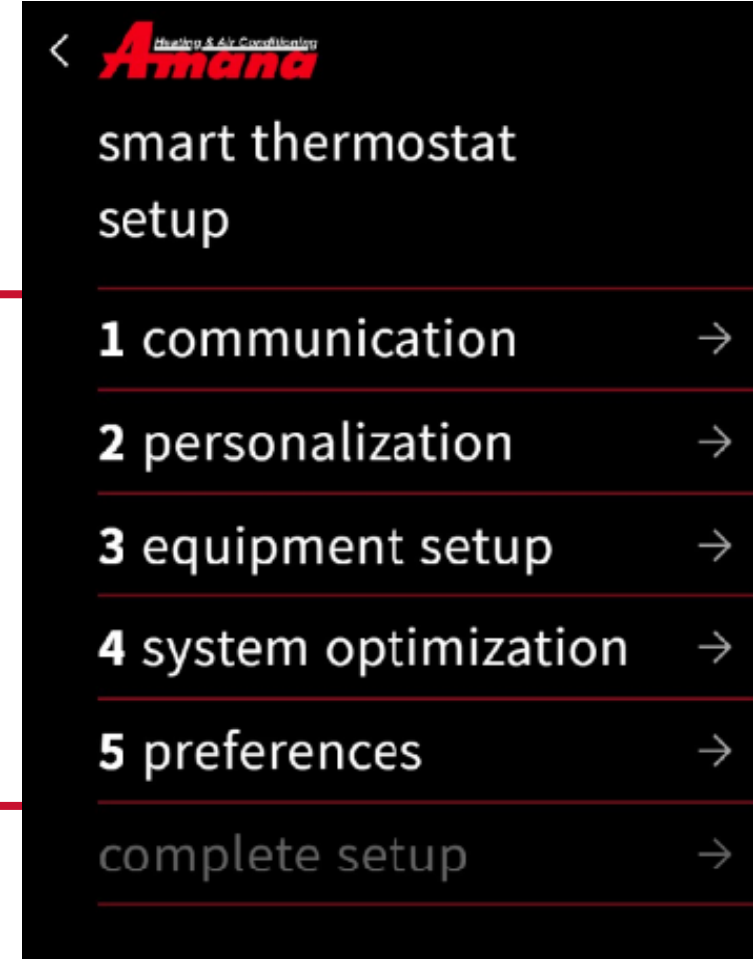

For detailed menu settings

www.amana-hac.com

Full Set-up

Step 1 - Communication

- Configures Communication Networks.
- Select home Wi-Fi to search for networks.
- With Wi-Fi configured, the system can check the software version and update software to the latest version automatically.
- Note:
 - Wireless router must be password protected.
 - Compatible with 5Ghz routers which supports 2.4Ghz
 - Equipment type displays the equipment selected on start up.

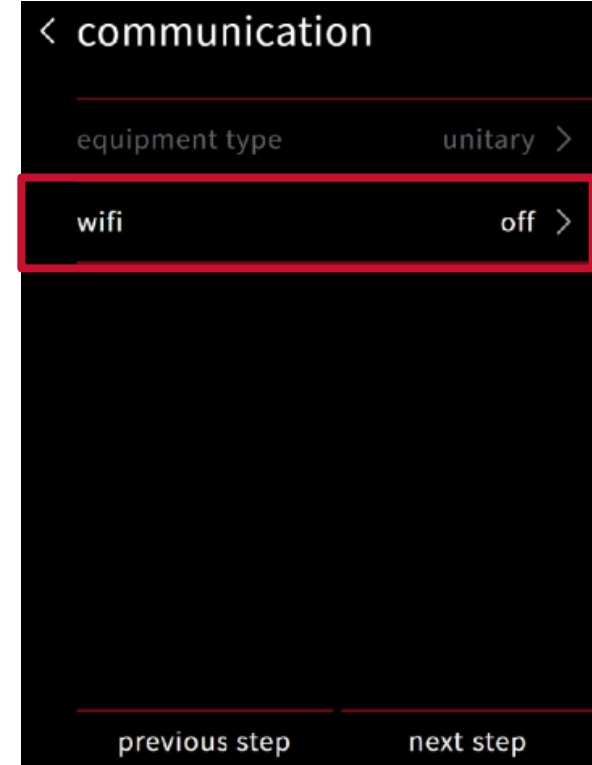
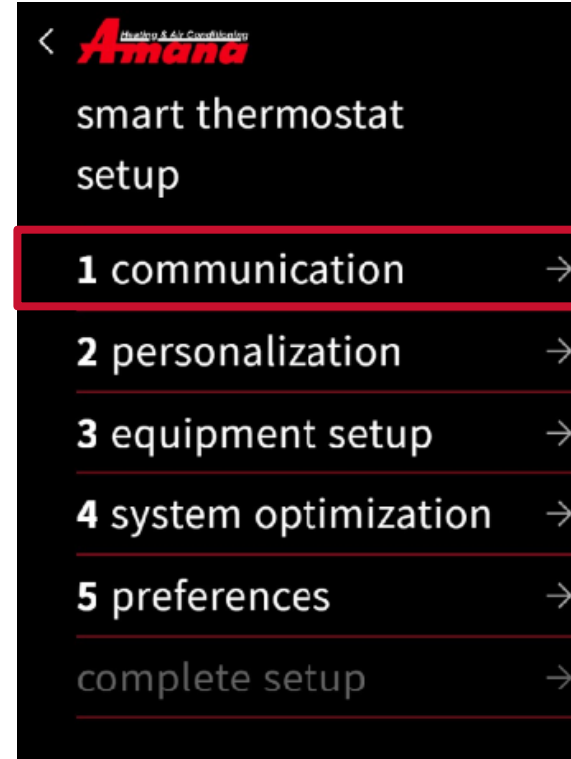

Thermostat must be updated to version 3.5.4 or later for R-32 software compatibility.

Full Set-up

Step 2 - Personalization

- Tapping the personalization tab allows you to edit default information.
- Personalization displays:
 - Language.
 - Large font selection.
 - Date & Time.
 - If Wi-Fi is connected, date & time are set automatically.
 - Thermostat Name.
 - Degree Units.

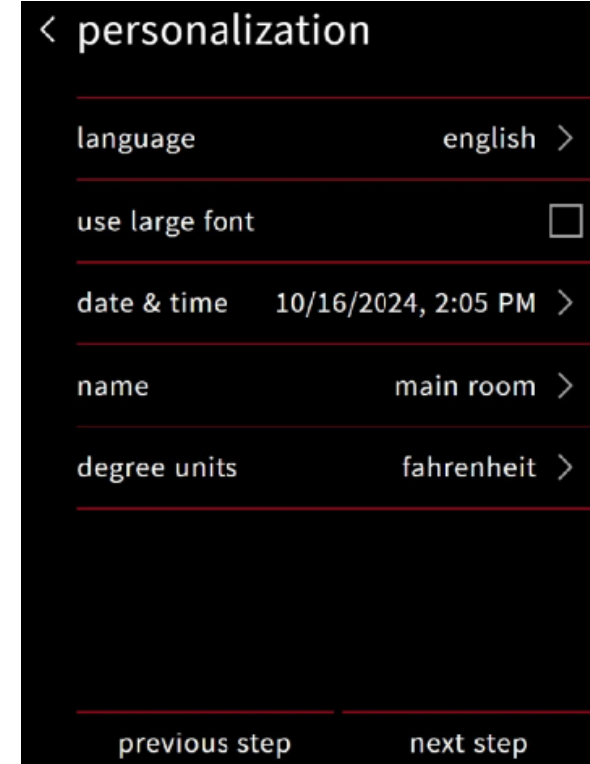
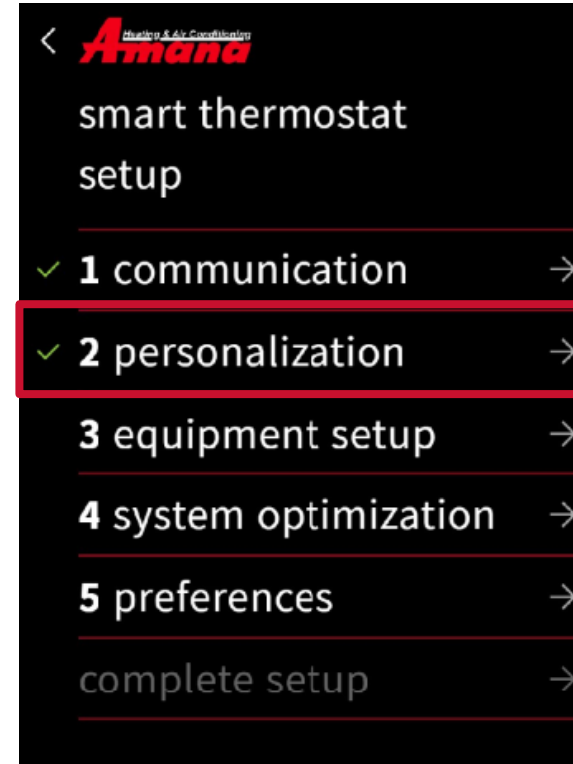

Full Set-up

Step 3 - Equipment Set-up

- Displays equipment found by searching the communication network, or by adding/removing equipment and accessories from the preset list.
- The unit that is identified determines the list of configurations that will be displayed.
 - View unit Specifications.
 - Configure
 - Cool settings
 - Heat Settings
 - Heat Pump Settings
 - Humidifier Relay
 - Heater Kit

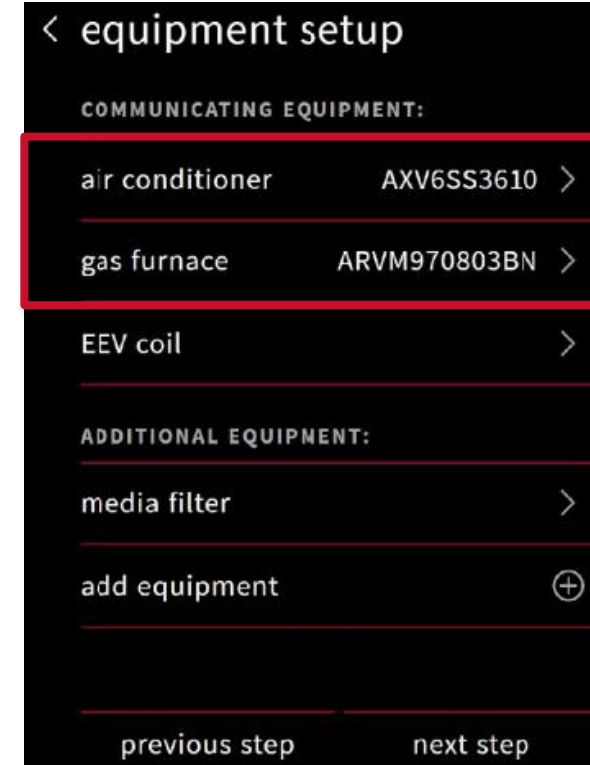
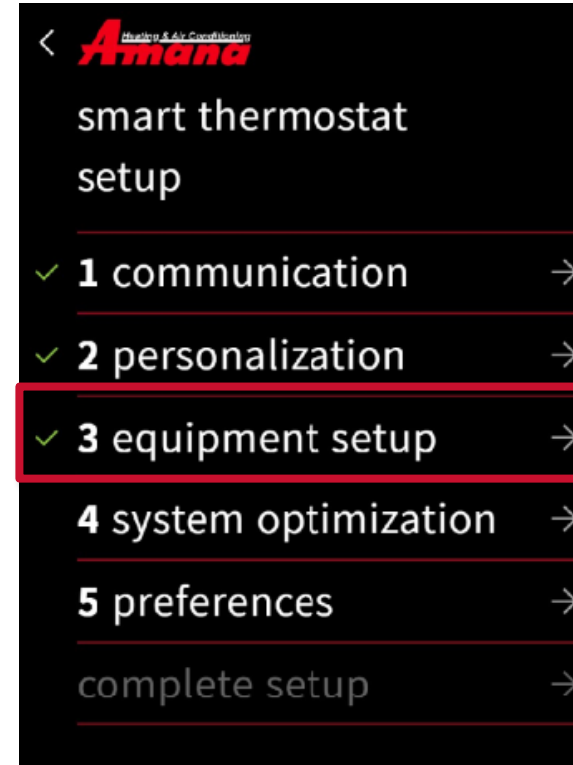

Cool Settings

Cool Airflow Trim

- Airflow may be adjusted from -15% to Max
 - High airflow is adjusted from -15% to +15%
- Adjusting your intermediate and low airflow trim settings lower can help improve dehumidification.
 - Before adjusting airflow trim settings, verify duct system and airflow requirements before adjusting these settings.
- Refer to IO manual for restricted airflow combinations.

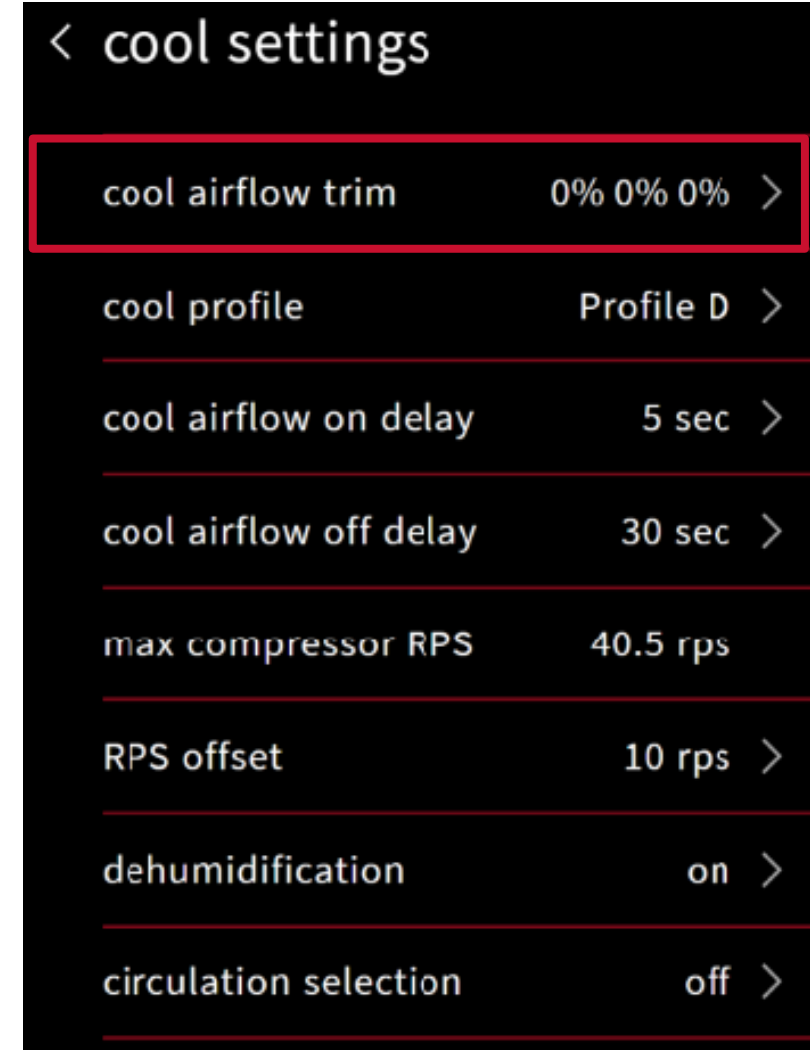

Cool Settings

Cool Profile

- The System offers several custom ON/OFF ramping profiles for cooling.
- These profiles may be used to enhance cooling performance and increase comfort level.

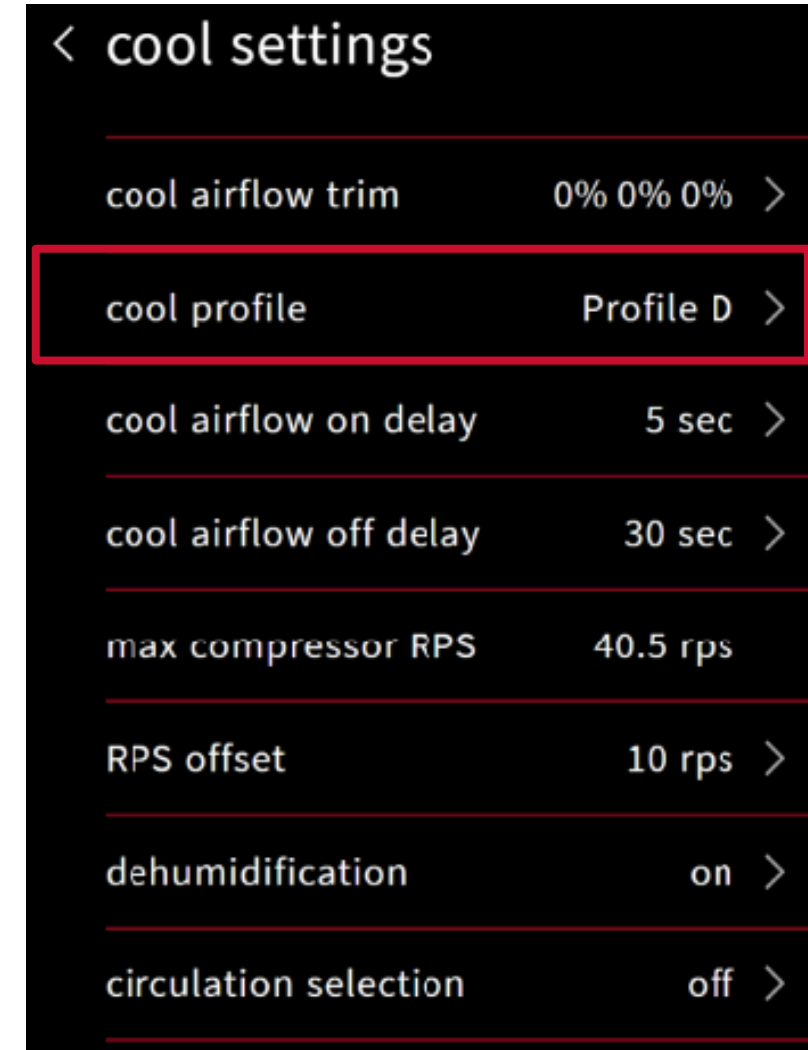

Cool Settings

Dehumidification

- The thermostat reads the indoor humidity level.
 - Target humidity setpoint is adjusted once setup has been completed.
- The thermostat controls the humidity level of the conditioned space using the cooling system.
- Dehumidification is engaged whenever a cooling demand is present and humidity levels are above the target level.
 - Circulating fan output is reduced
 - System run time increases
- Dehumidification demand is controlled based on humidity differential between set point and detected.
- If room temperature is 2°F higher than set temperature, dehumidification demand will be sent to prioritize to room temperature control.

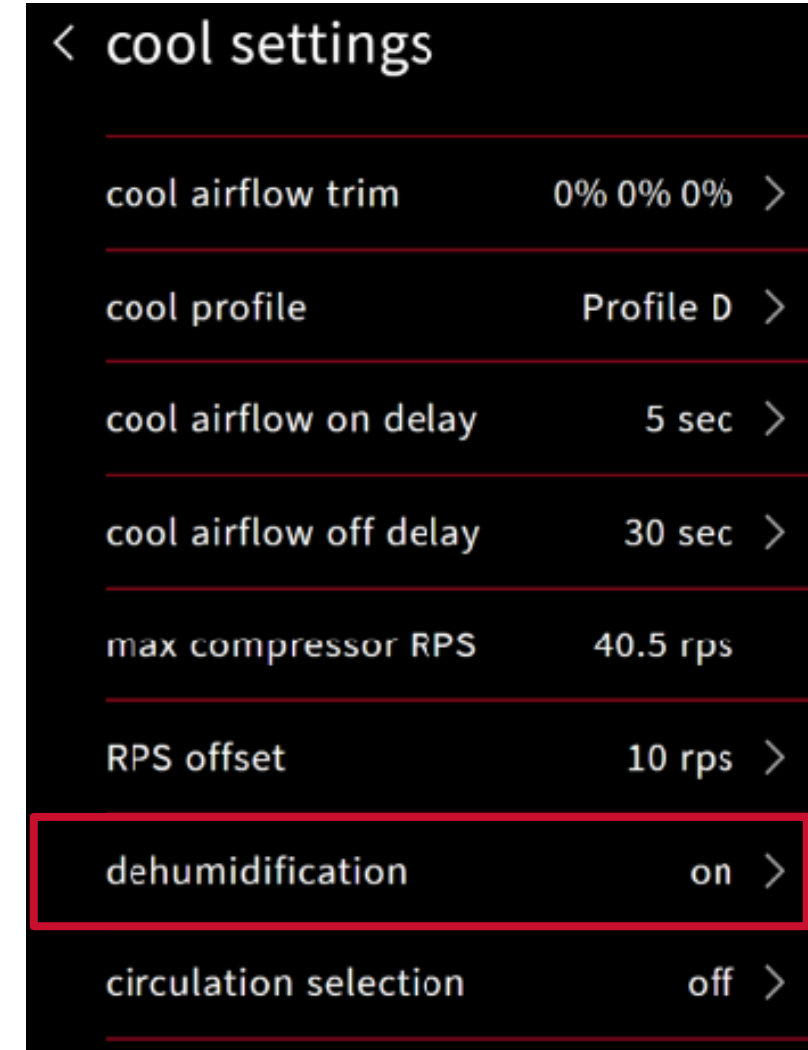

Dehumidification Performance

- The performance can be improved by changing the dehumidification profile in cool settings to “A”, “B” or “C”.
 - The setting can be changed from the dehumidification setting menu at any time when required.
- The minimum compressor speed will be locked depending on the selected profile.
- This operating range limitation will be unlocked when the humidity reaches the set value.
- There must be a call for cooling and a demand for dehumidification.

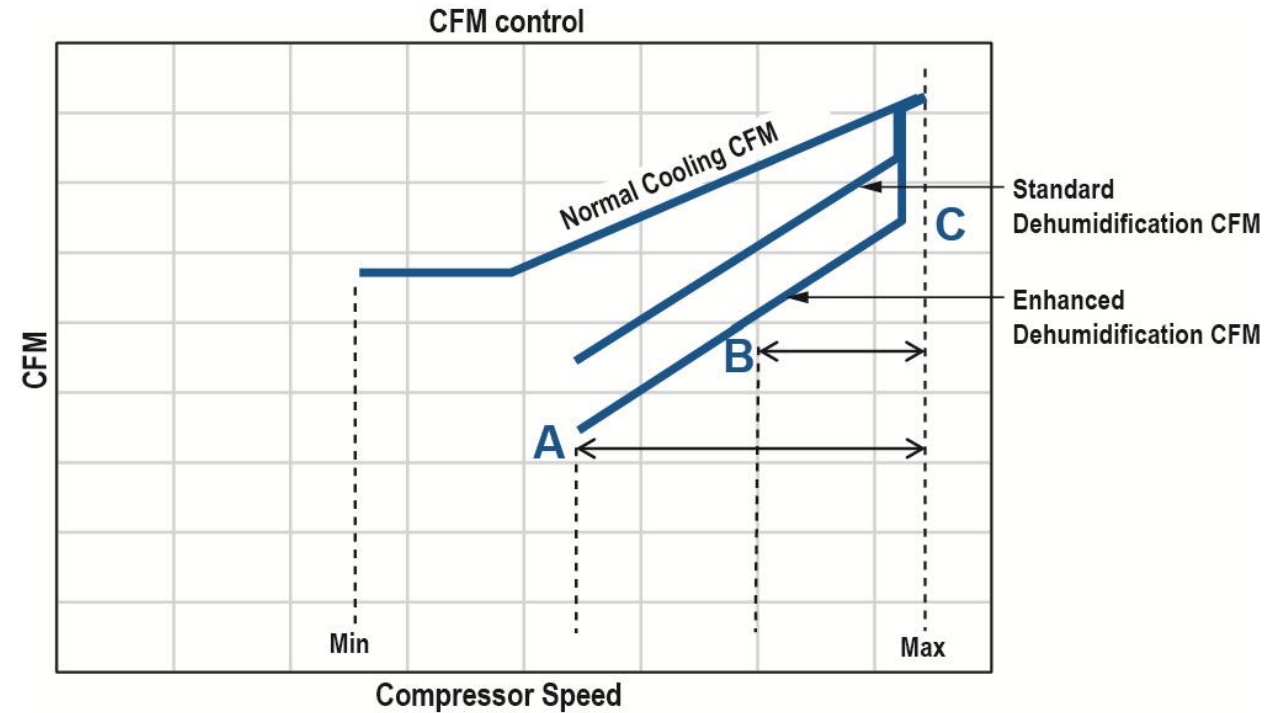

Dehumidification Levels			
STANDARD	A	B	C
Improves dehum by lowering airflow	Max dehum with wide compressor and airflow range	Moderate dehum with reduced compressor and airflow range	Min dehum, compressor fixed at 100%, airflow @70%

Heat Settings

Heat Airflow Trim

- User can change the airflow trim at high, intermediate and low compressor speed.
- Airflow may be adjusted from -15% to +15%
- Refer to IO manual for restricted airflow combinations.
- Note: Lower heating speeds will reduce electrical consumption, lower operating sound levels of the blower, and increase the outlet air temperature delivered to the home.

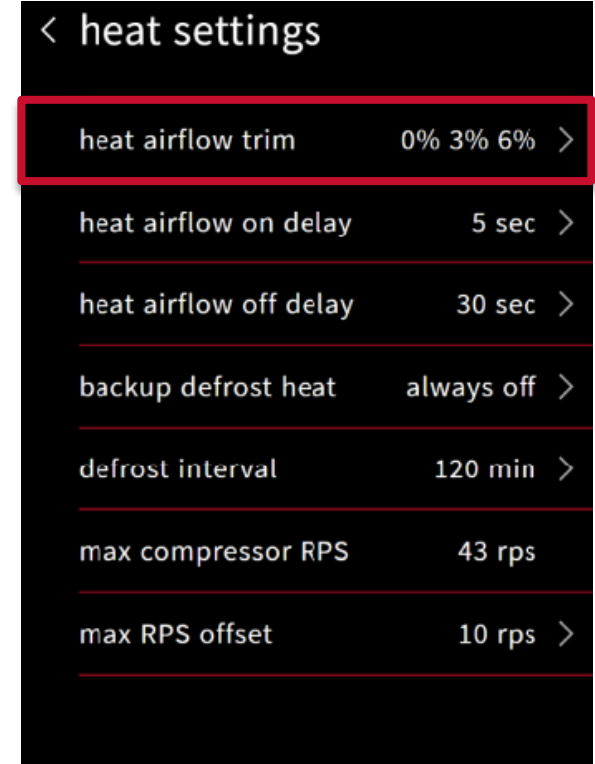
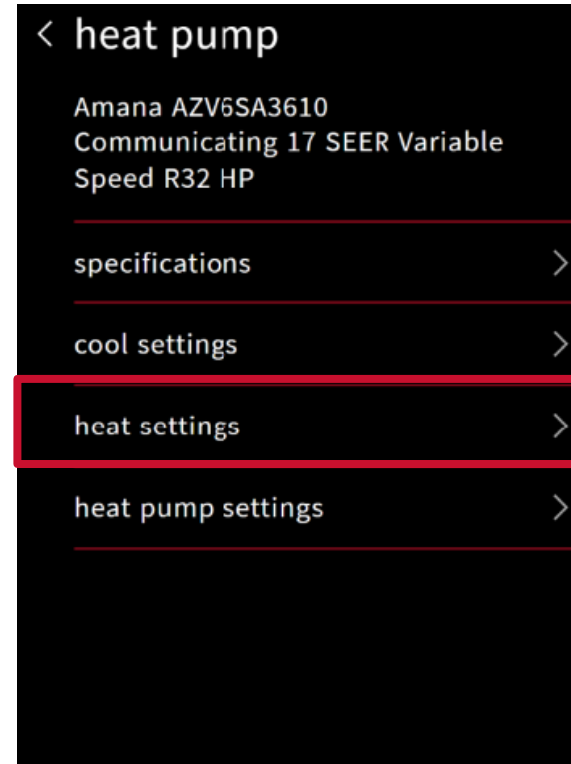

Heat Settings (Heat Pump)

- Defrost heat
 - You can select the outdoor temperature for backup heat to activate during defrost. (At or below 30°F- 65°F or ON/OFF).
- Defrost interval
 - Every 30, 60, 90 or 120 minutes is selected from the thermostat menu.
- If defrost sensor drops below freezing temp. during the selected interval, ODU PCB initiates defrost cycle.
 - The ODU fan motor and compressor will de-energize.
 - The reversing valve switches from heating to cooling operation.
 - ODU PCB communicates to energize back up heat if enabled.
 - The coil and defrost sensor temperatures are monitored every 5 seconds.
 - When the coil temperature reaches 54°F and the defrost sensor temperature is greater than 43°F for 30 seconds, defrost operation is terminated.



Defrost Operation

Intelligent Defrost

- If it takes longer than 5 minutes to reach target coil temperature, then the initial time interval you selected will be shortened for entering the next defrost mode.
- If it takes less than 5 minutes during the defrost mode to reach the target coil temperature, then it will lengthen the interval before entering the next defrost mode.

Intelligent Defrost



Auxiliary Heat Logic

- Aux (Electric Strip Heat) and backup gas heat can engage above lockout temperature in the following conditions:
 - The space temperature is approximately 4° lower than the set point.
 - There is a demand between 110% - 200% from the system.
- For Dual Fuel operation only, you can select to prioritize efficiency or comfort
 - Selecting prioritize efficiency, the selected balance point will be a hard lockout.
 - Heat pump operation above balance point.
 - Furnace operation below balance point.
 - Selecting prioritize comfort will cause the system to run with the logic listed above.

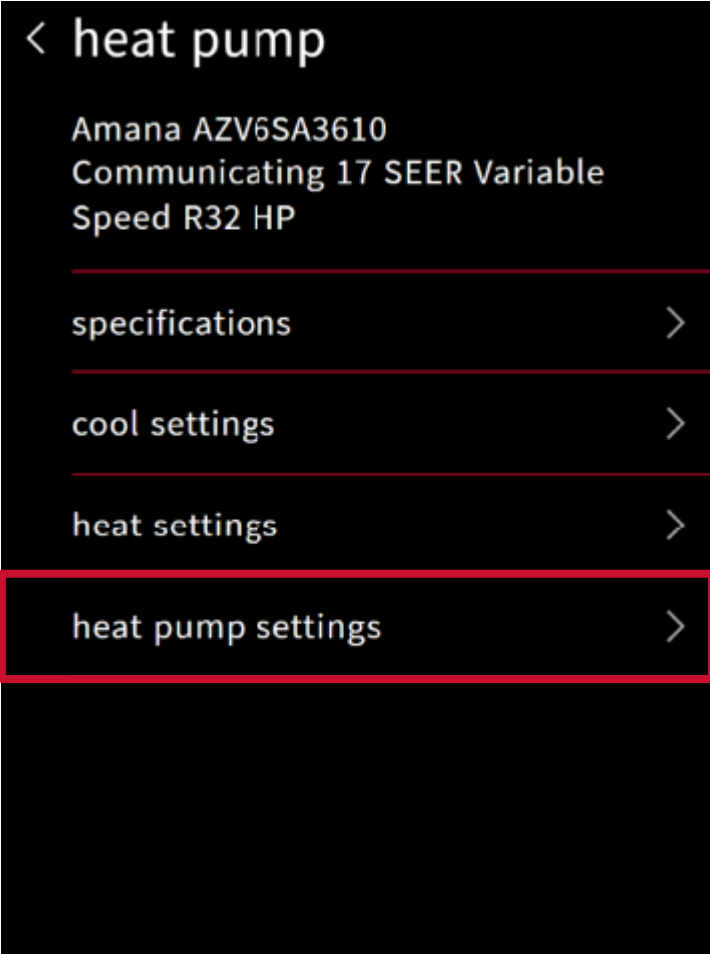

Electric Strip Heat

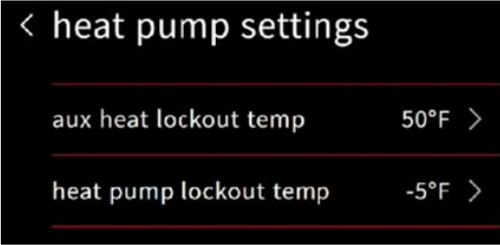

Dual Fuel

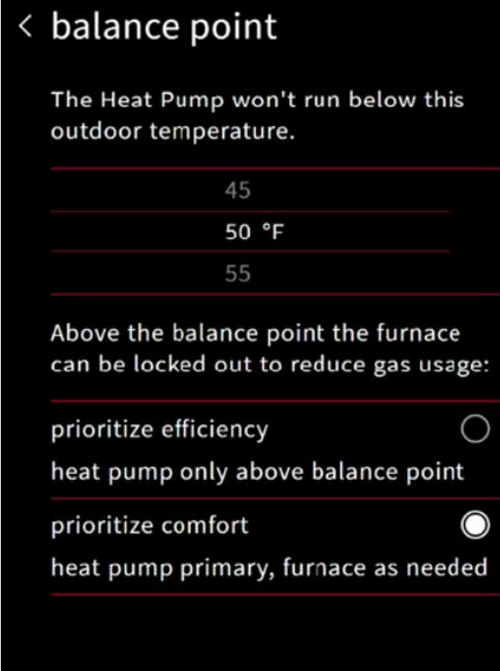

Add Equipment

- The Amana Smart thermostats are compatible with multiple accessories.
 - Aux heat source
 - Humidifier
 - Dehumidifier
 - You can install the aux heat source, humidifier, and dehumidifier by using aux terminals.
 - UV Bulb
 - Electronic Filter
 - HEPA filter
 - EWC Zone Board
 - D24V Gateway

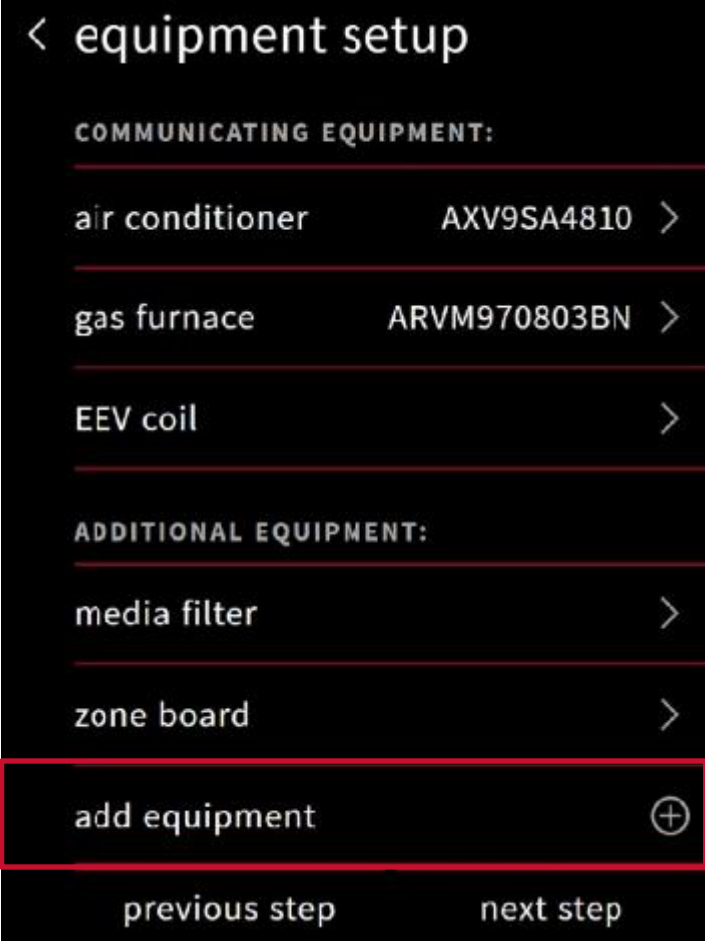

Zoning control accessory board Air Handler (120 VAC Accessory)

- R-32 Leak Detected
- Alarm Activated
- All Relays on Zone Mitigation Board switch
- Power to accessory is removed
- Mitigation Mode Ends, Relays switch back and accessory has power again
- Terminals are designated
 - TB11(CTL-COM)
 - TB12 (CTL-NO)
 - TB13 (CTL-NC)

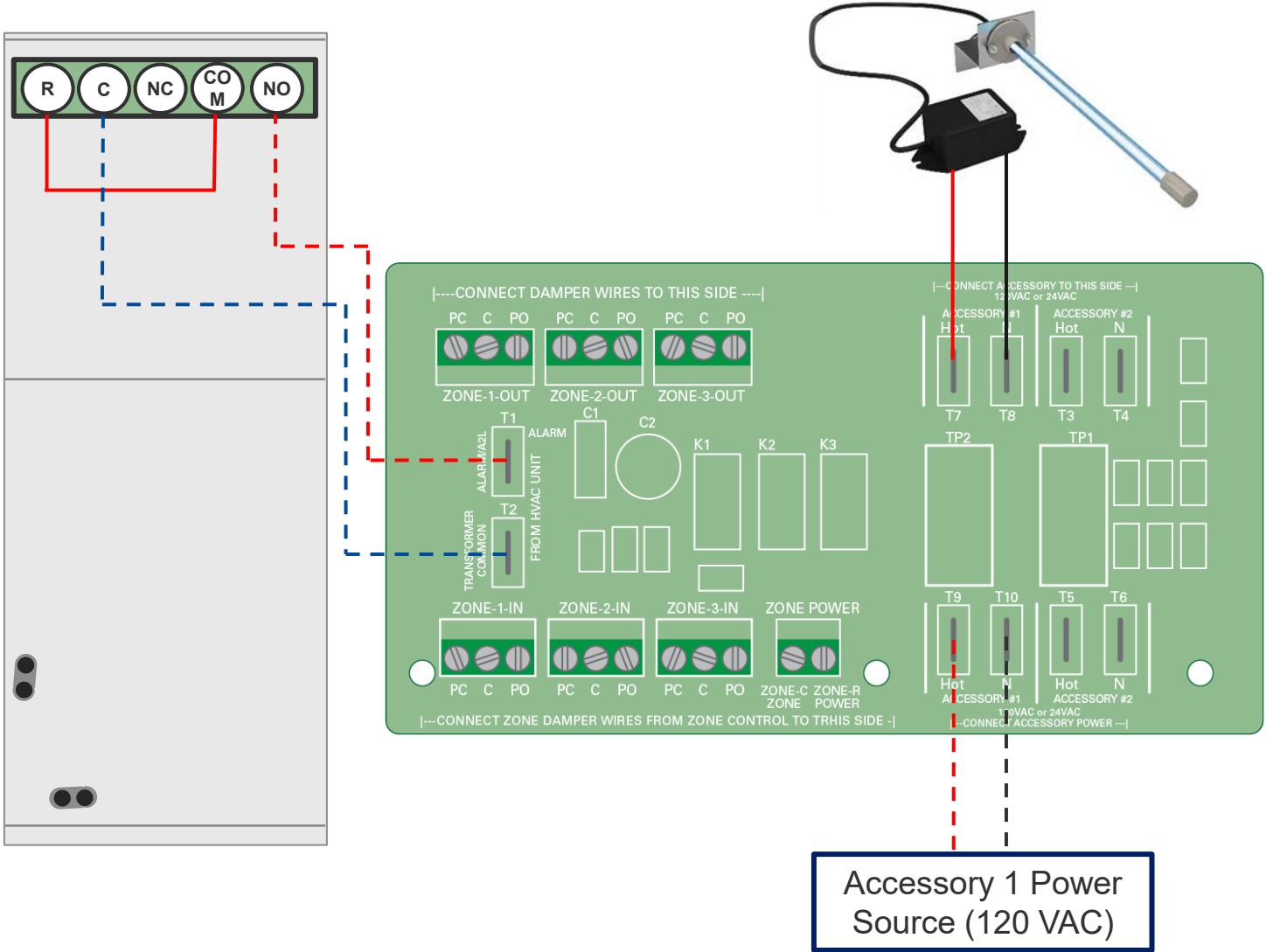

Zoning control accessory board DFVE using Aux Contacts on Daikin One 24VAC Accessory

- R-32 Leak Detected
- Alarm Activated
- All Relays on Zone Mitigation Board switch
- Power to accessory is removed
- Mitigation Mode Ends, Relays switch back and accessory has power again
- Terminals are designated
 - TB11(CTL-COM)
 - TB12 (CTL-NO)
 - TB13 (CTL-NC)

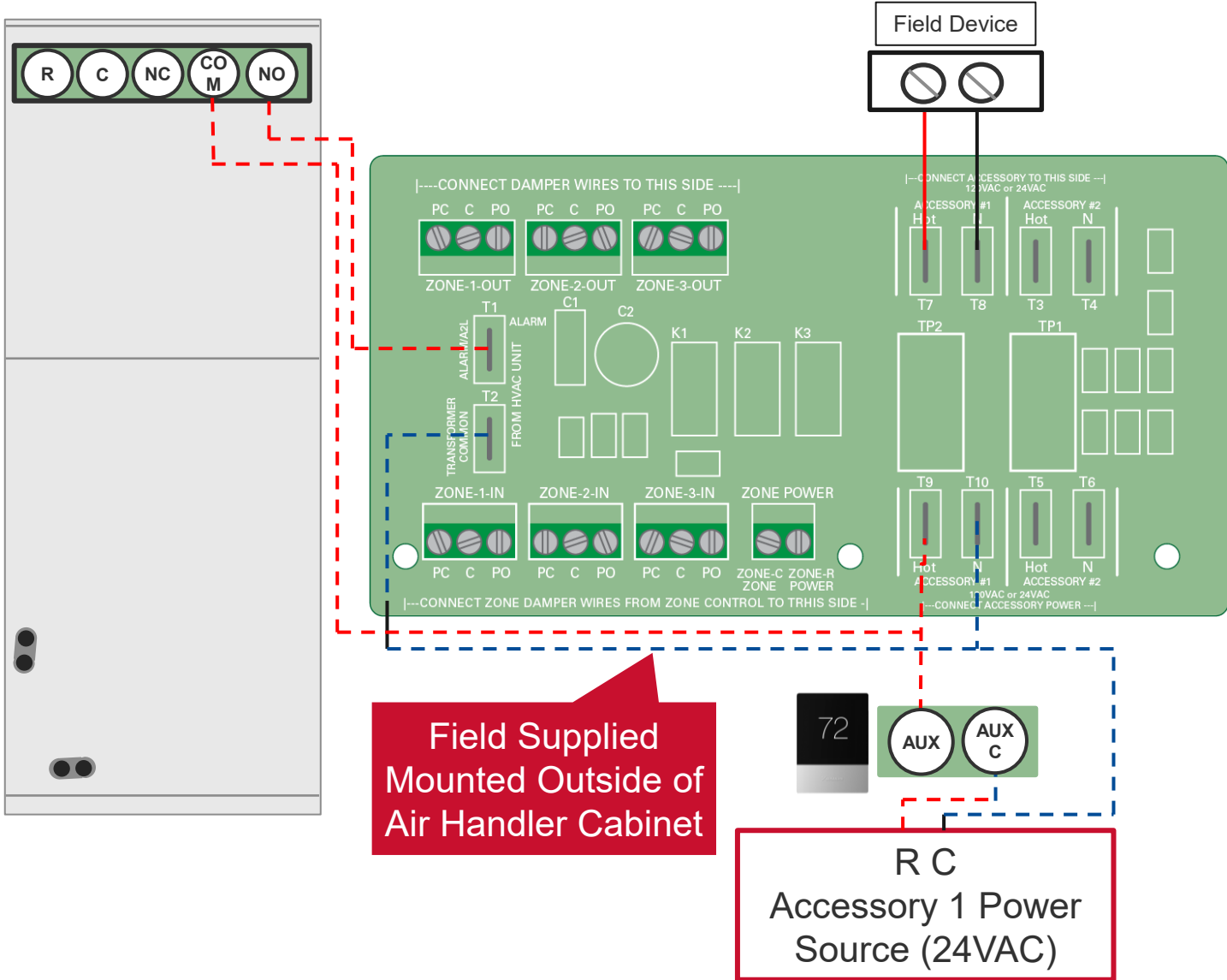

Auxiliary heat source

- Selecting add equipment will allow you to configure an auxiliary heat source.
- This is not for set up of Heater Kit for backup electric heat.

Examples: Boiler, Duct heater, Boiler with hot water coil

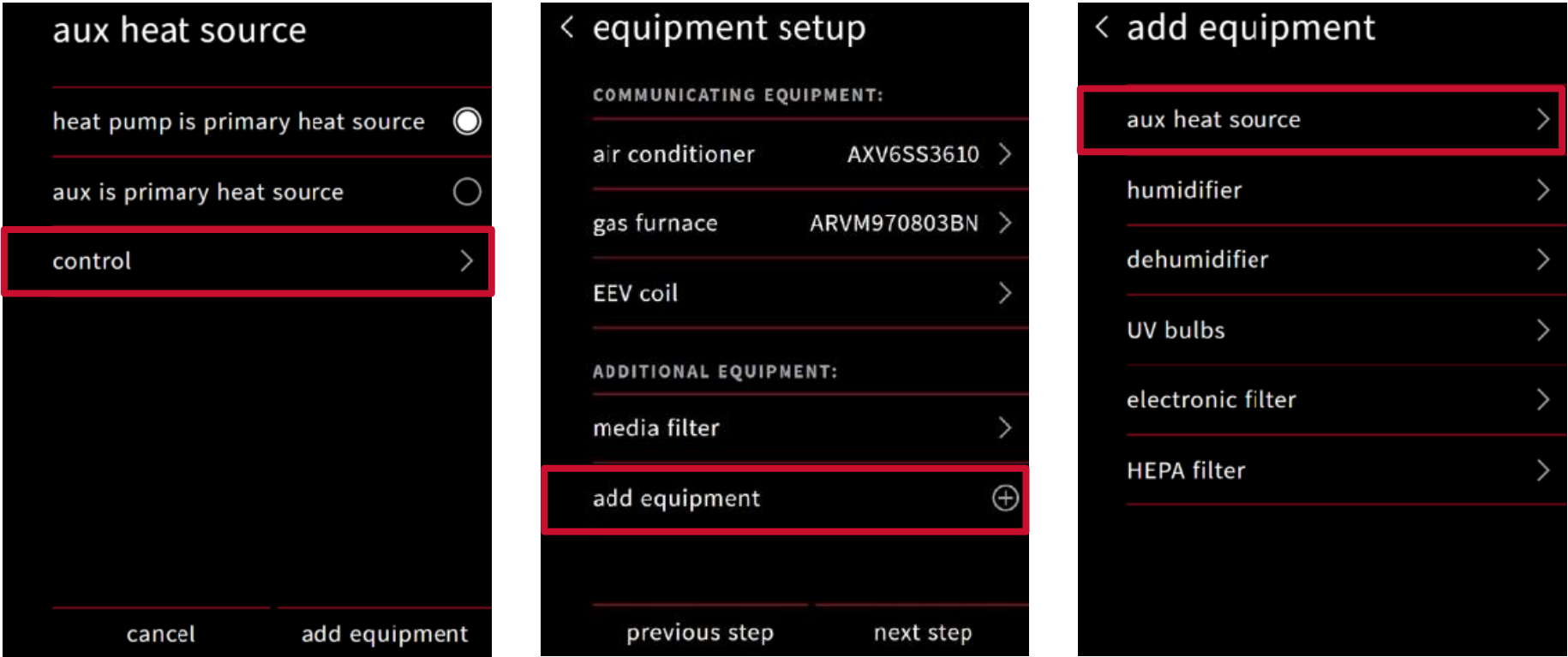

Aux heat source is the only control option for an AC only outdoor unit.

Aux Heat Setup on Amana Stat

Secondary Heat Settings

- The control section will allow you to adjust settings such as lockouts and secondary heat activation temperature.

***Emergency Heat mode will appear as a system mode when connected to heat pump units and can be used to directly turn on the aux heat source if enabled.**

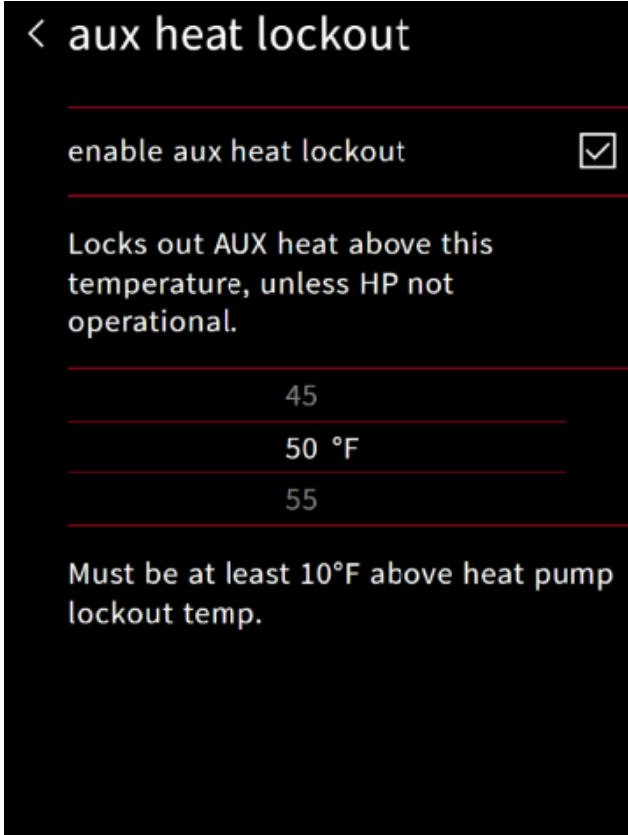
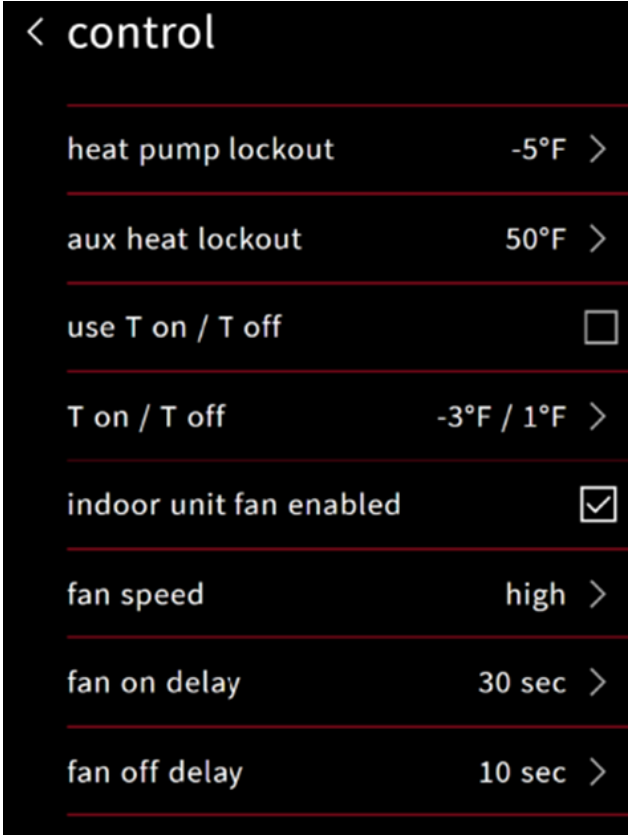

T on/T off Control

- T on and T off provide an alternative control method to have the main AC/heat pump control the aux heat source using its PI control algorithm.
- T on/T off is the only control option for AC- only outdoor units
 - If the indoor unit is a gas furnace, or is an air handler with a heater strip, these heat sources will be controlled around the heat setpoint by the demand-based algorithm.
 - The aux heat source will be controlled independently.

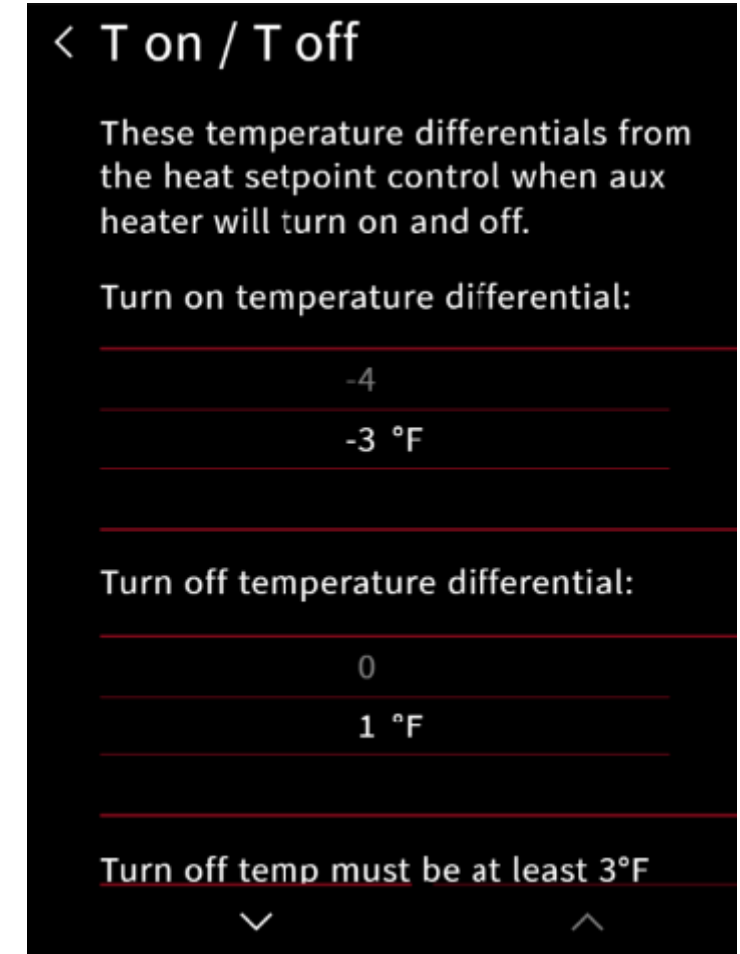

Aux Heat Control

- When heat pump is the primary heat source:
 - Heat pump lockout temperatures are adjustable from -20°F to 65°F in 5°F increments. (default 15°F)
 - Auxiliary heat lockout temperatures are adjustable from -10°F to 75°F in 5°F increments. (default 50°F)

Auxiliary heat demand:

- T on differential is adjustable from -7°F to -3°F in 1°F increments (default -3°F)
- T off differential is adjustable from -4°F to 1°F in 1°F increments (default 1°F)

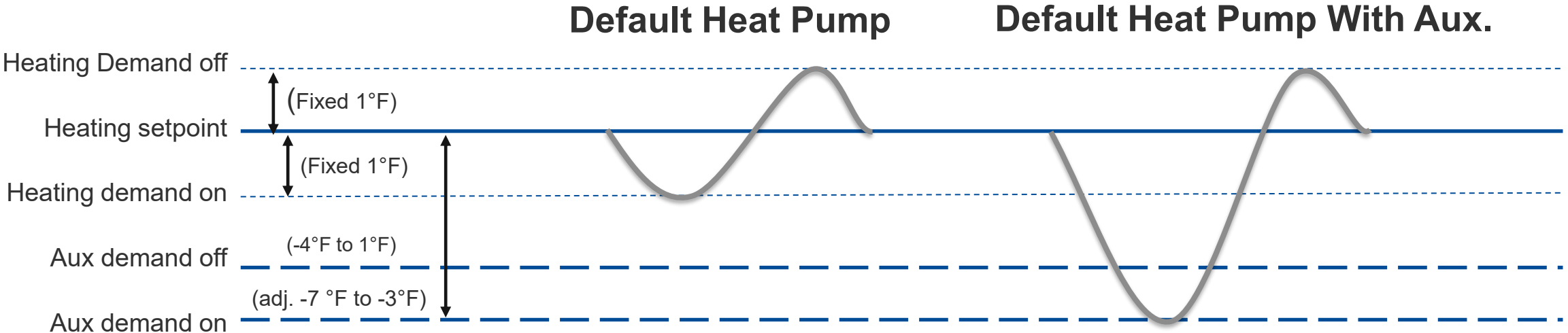

Aux Heat Control

- When auxiliary heat is the primary heat source:
 - Heat pump lockout temperatures are adjustable from -20°F to 65°F in 5°F increments. (default 15°F)
 - Setpoint differential can be set at -9°F, -7°F, -4°F, and -2°F. (default -2°F)

Heat pump demand:

- T on differential can be set at -1°F or -2°F. (default -1°F)
- T off differential is fixed at 1°F.

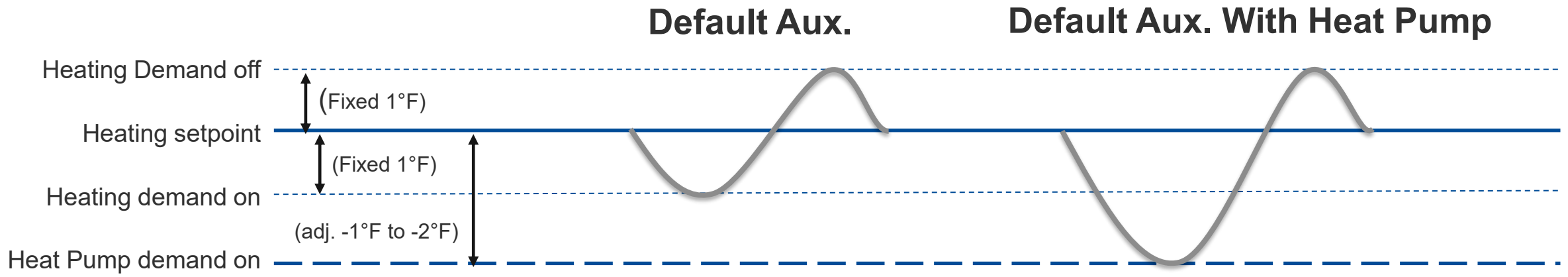

Zoning control accessory board Air Handler (24VAC Accessory)

- R-32 Leak Detected
- Alarm Activated
- All Relays on Zone Mitigation Board switch
- Power to accessory is removed
- Mitigation Mode Ends, Relays switch back and accessory has power again
- Terminals are designated
 - TB11(CTL-COM)
 - TB12 (CTL-NO)
 - TB13 (CTL-NC)

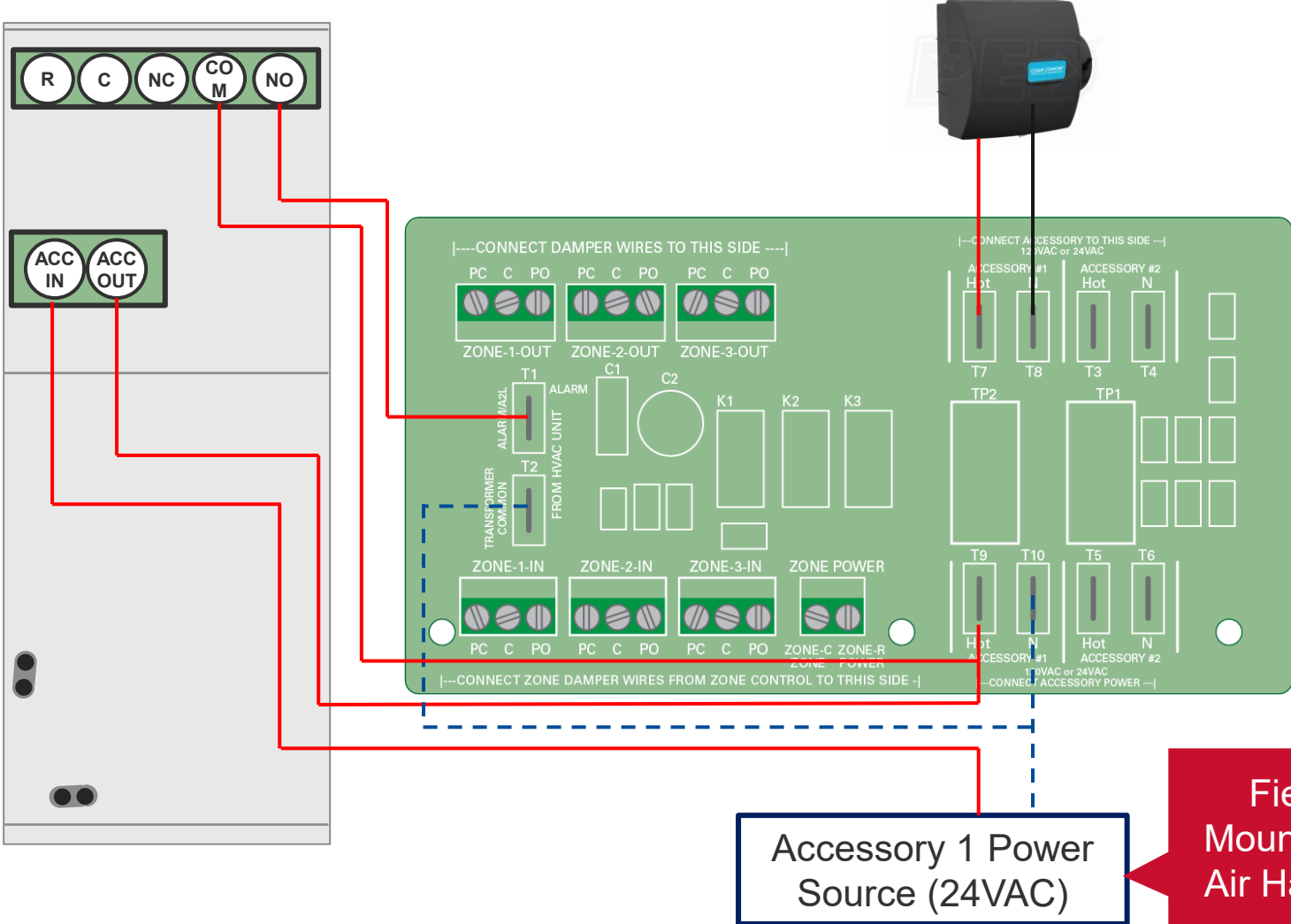

Humidifier Relay

2 Stage Furnaces (non A2L)

- Connect humidifier to powered contact on HUM terminal (120 Volt).
 - In equipment setup, select the gas furnace to turn on the heat/humidifier relay.
 - Set the desired humidity setpoint under the comfort tab in the settings after completing the setup.
- The AUX terminals only need to be setup if the control wiring for the humidifier is run directly to the Daikin One thermostat.

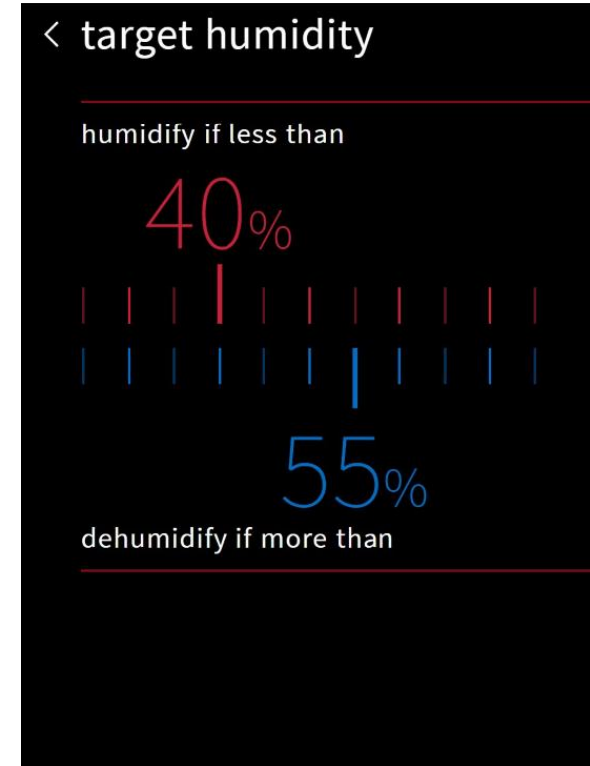
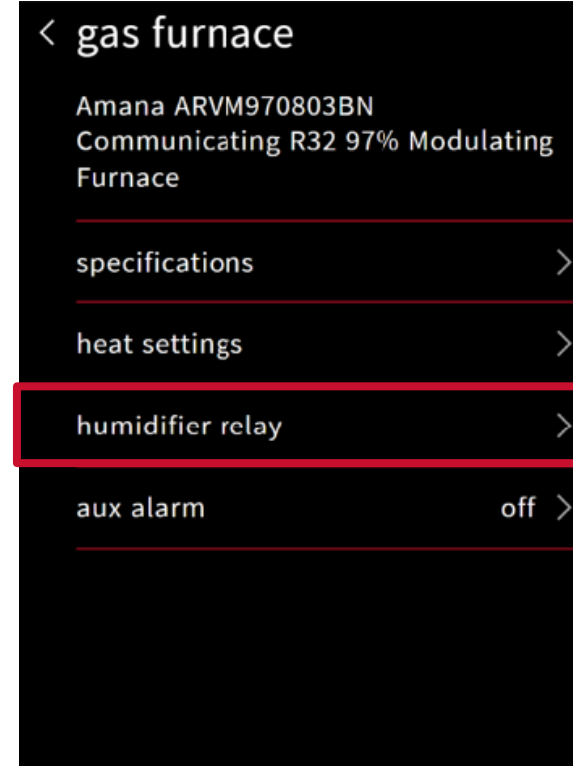

Humidifier Relay

Modulating Furnaces (non A2L)

- Connect humidifier to the dry contacts (HUM1 and HUM2) on furnace PCB.
- Set the desired humidity setpoint under the comfort tab in the settings after completing the setup.

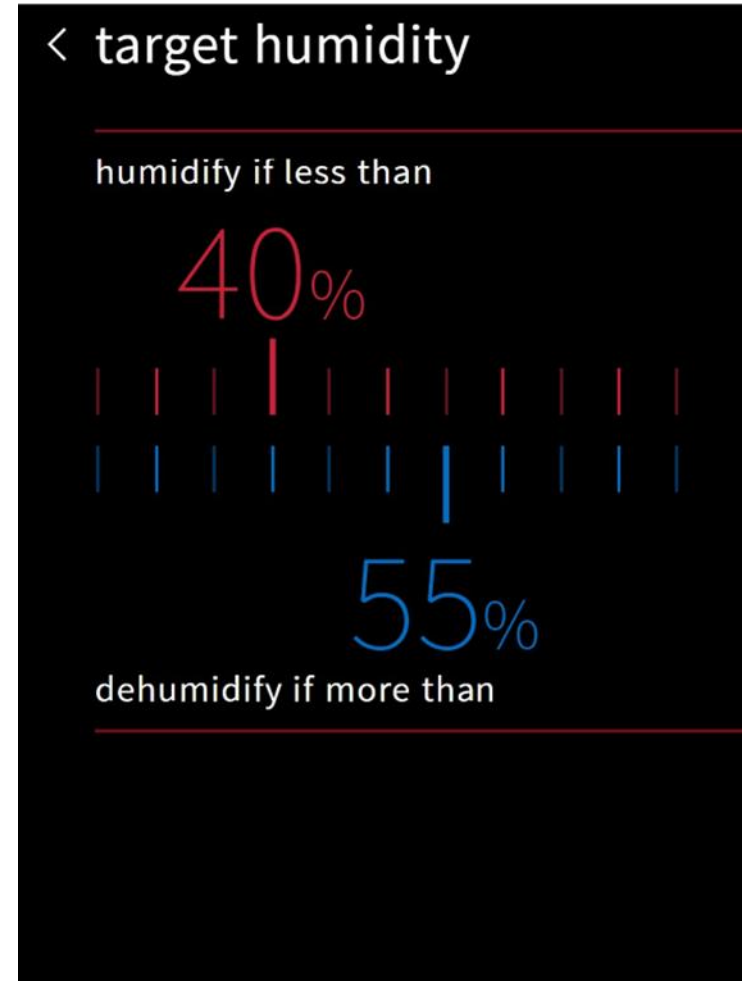

Humidifier/EAC Example

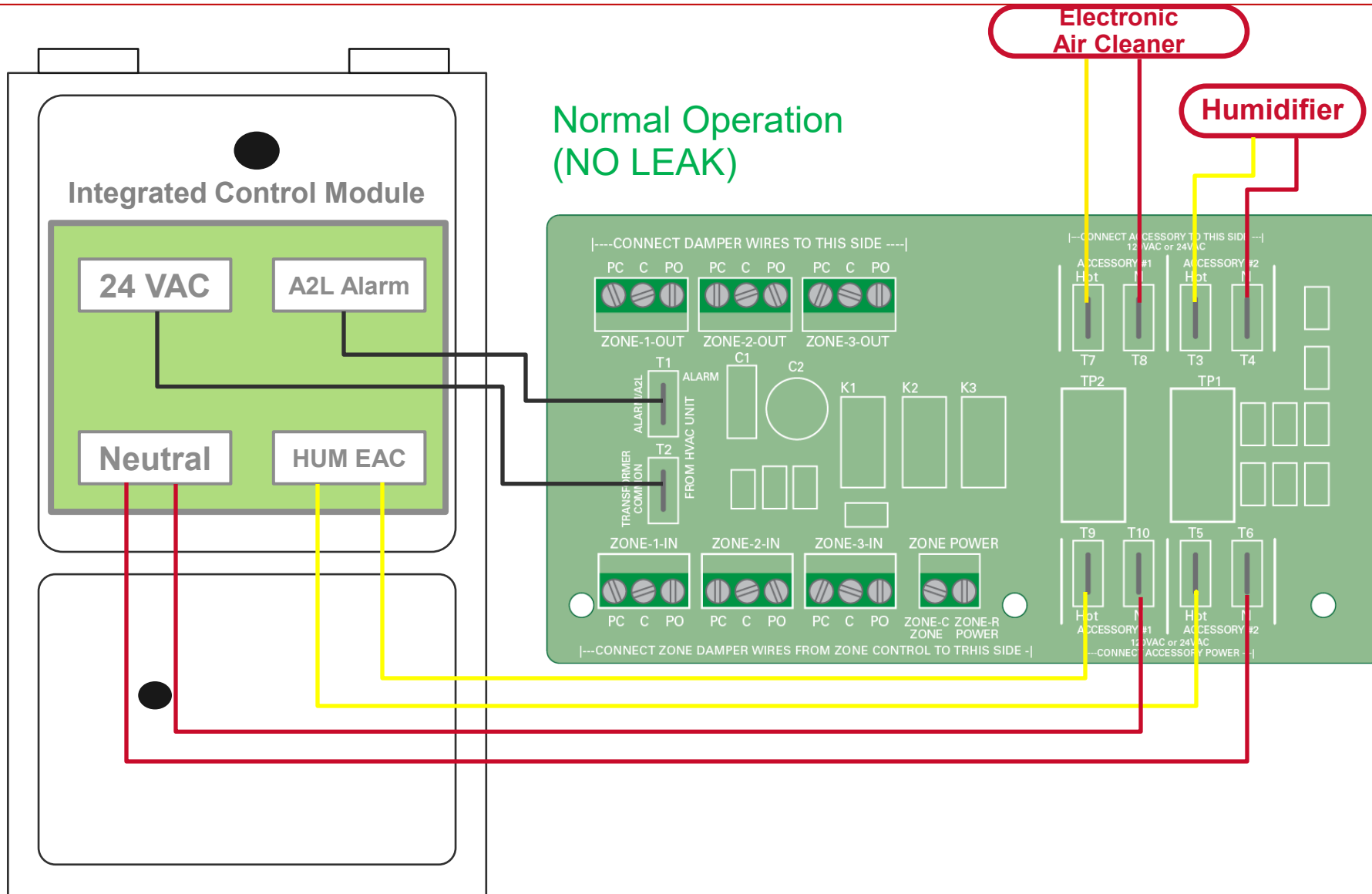

Normal Operation
(NO LEAK)

Accessory Power: ON

- R-32 Leak Detected
- Alarm Activated
- All Relays on Zone Mitigation Board switch
- Power to accessory is removed
- Mitigation Mode Ends, Relays switch back and accessory has power again.

Auxiliary Alarm

Air Handlers

- The control is equipped with two Auxiliary Alarm terminals.
 - Alarm terminals (TB4 and TB5) are typically utilized in series with a condensate switch but could also be used with compatible CO2 sensors or fire alarms.
- The auxiliary alarm switch is normally close.
 - Opens when the alarm occurs.
- Note: Errors will be maintained in the equipment's fault history.

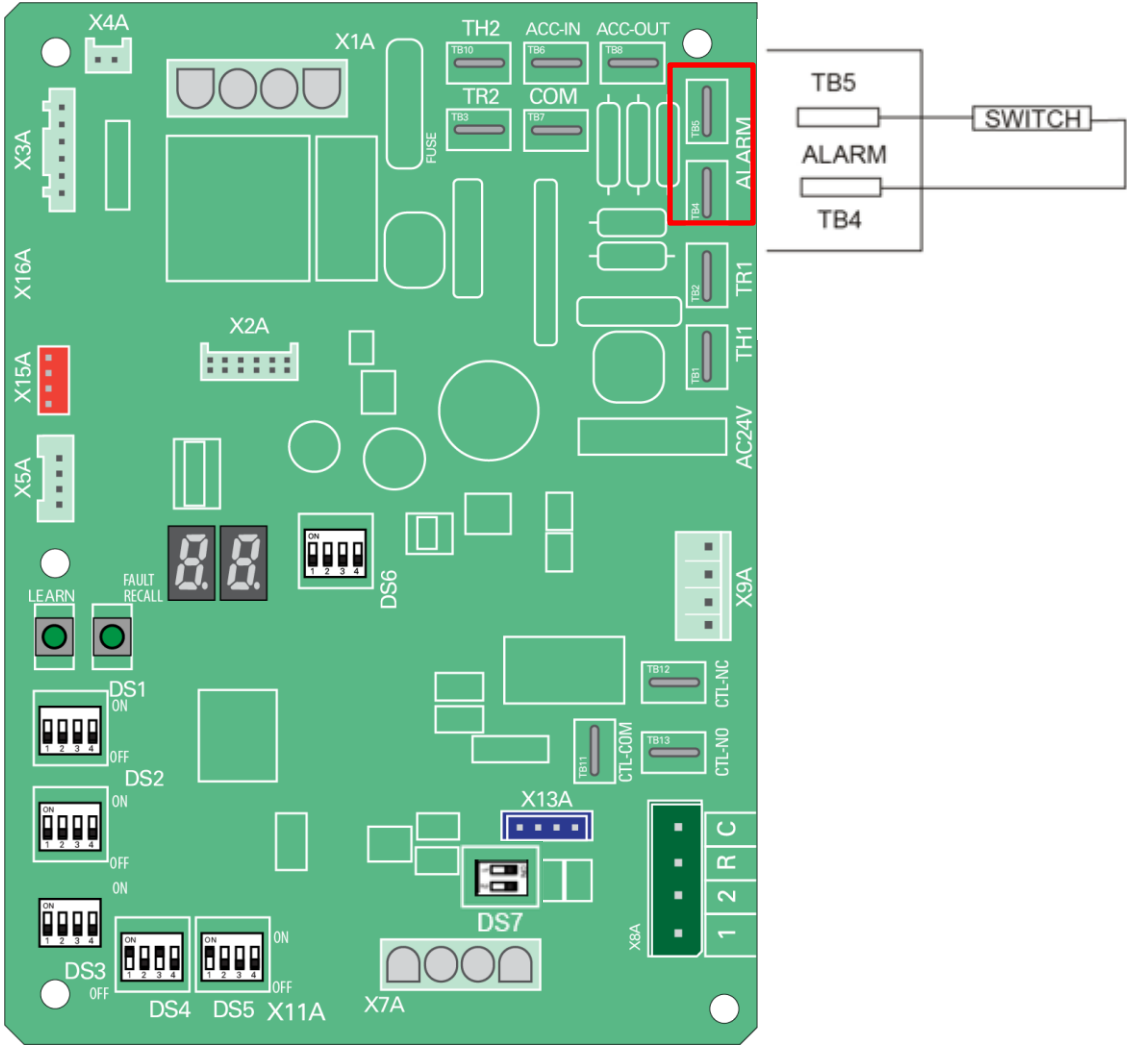

Auxiliary Alarm

Gas Furnace 24VAC Auxiliary Alarm Switch (communicating set up ONLY)

- Primarily to be used for a condensate switch input.
 - Must remove jumper prior to adding the condensate switch.
- AUX switch is normally closed
 - Opens when the water level in the evaporator coil base pan has reached an undesirable level
- The Aux alarm will respond by turning off the outdoor unit and display EEF on the LED display.
- If the AUX switch is detected closed for 30 seconds, normal operation resumes, and error message no longer displayed.
- In the Amana Smart Thermostat dealer edit menu, under 'equipment set up', select the furnace and then select 'add alarm'.

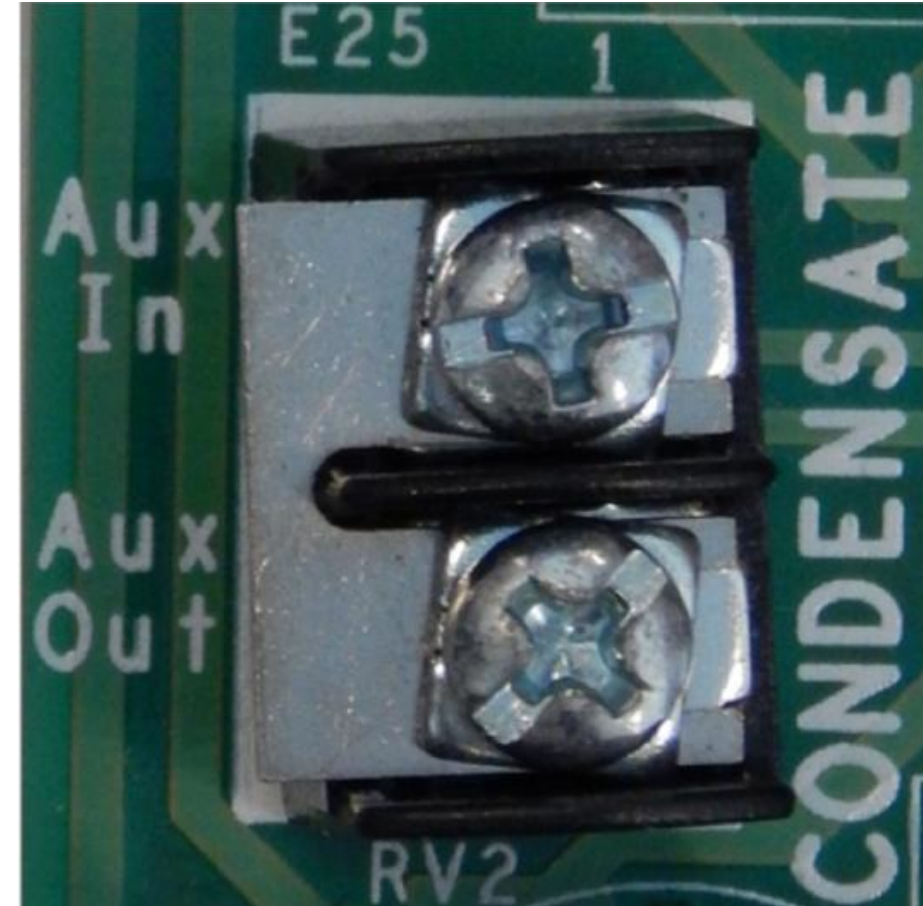

System Test

- Running system test is required for the inverter units before proceeding to complete set-up.
 - Thermostat must be calibrated.
 - The test needs to be completed without any errors.
- When the tests are completed, the run test screen is displayed.
 - System test is complete only when display code E11 notice clears from the seven-segment display on the heat pump or air conditioner.
 - System must be in OFF mode while running the test for the E11 code to clear.

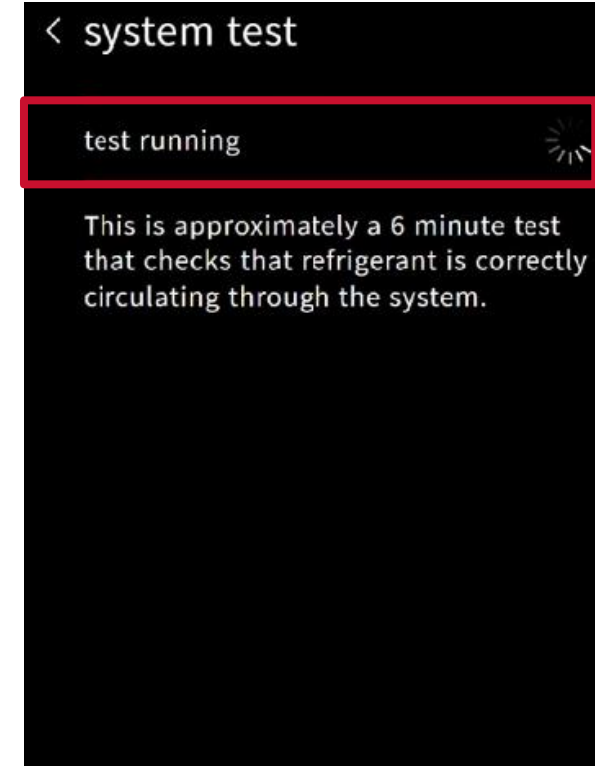
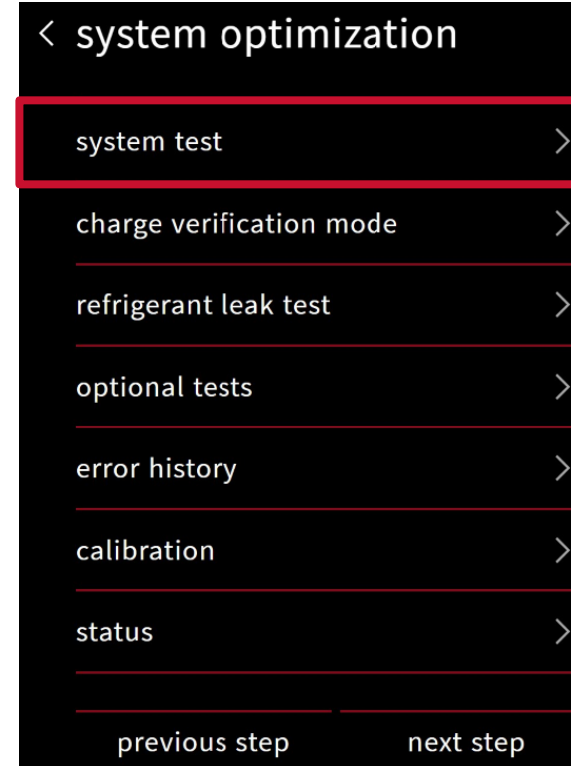

System Optimization

Charge Verification Mode

- Charge verification allows for a system operation approximately 50% capacity for 1-2 hours.
- The system will stop when the “stop test” button is pressed or once the test is complete.
 - Note: For proper charging of a system, please see equipment installation manual.

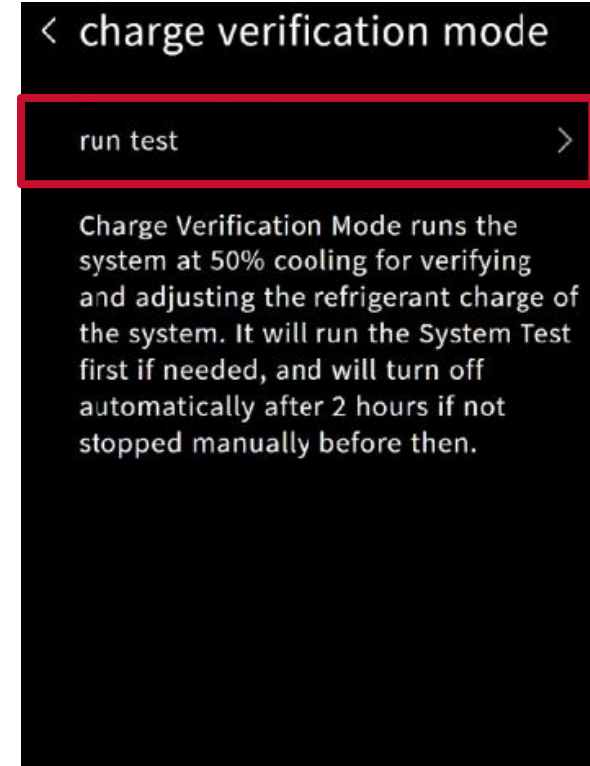
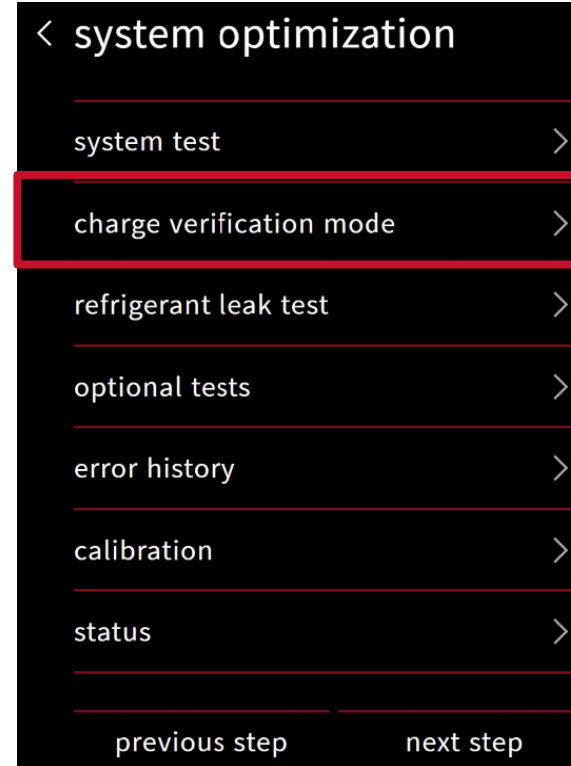

Verify Refrigerant Charge



Sub-cooling

- Before starting Charge verification test confirm indoor airflow and static are within tolerance before verifying subcooling measurement.
- If ambient is in between 65°F and 105°F and the unit is operating at 50%, Add or remove refrigerant per the chart as shown.
 - If system is not in condition after the first 20-25 minutes, a message will be displayed on the thermostat stating the reason.
- If outdoor ambient temperature is < 65°F or >105°F.
 - Thermostat display will notify of that, and Charge verification will not be allowed. Weigh in charge.
- Subcooling value displays on the 7-segment display ONLY during charge mode.

CHARGE VERIFICATION TEST charging table (S-series)

OD Ambient Temp (degF)		< 65°F	65°F to 105°F					> 105°F
			AXV6SA	AXV6SS	AZV6SA	AZV7SA	AXV9SA	
Subcooling (degF)	1.5 ton	Weigh in charge	7 ± 1°F	7 ± 1°F	7 ± 1°F	-	-	Weigh in charge
	2 ton		*8 ± 1°F	*8 ± 1°F	*8 ± 1°F	8 ± 1°F	8 ± 1°F	
	2.5 ton		8 ± 1°F	8 ± 1°F	8 ± 1°F	-	-	
	3 ton		9 ± 1°F	9 ± 1°F	9 ± 1°F	8 ± 1°F	8 ± 1°F	
	3.5 ton		-	8 ± 1°F	8 ± 1°F	10 ± 1°F	-	
	4 ton		-	8 ± 1°F	8 ± 1°F	10 ± 1°F	10 ± 1°F	
	5 ton		-	10 ± 1°F	10 ± 1°F	-	-	

Full capacity charging table (S-series)

OD Ambient Temp (degF)		< 65°F	65°F to 105°F					> 105°F
			AXV6SA	AXV6SS	AZV6SA	AZV7SA	AXV9SA	
Subcooling (degF)	1.5 ton	Weigh in charge	10 ± 1°F	10 ± 1°F	10 ± 1°F	-	-	Weigh in charge
	2 ton		12 ± 1°F	12 ± 1°F	12 ± 1°F	14 ± 1°F	14 ± 1°F	
	2.5 ton		14 ± 1°F	14 ± 1°F	14 ± 1°F	-	-	
	3 ton		13 ± 1°F	15 ± 1°F	15 ± 1°F	8 ± 1°F	8 ± 1°F	
	3.5 ton		-	8 ± 1°F	8 ± 1°F	9 ± 1°F	-	
	4 ton		-	9 ± 1°F	9 ± 1°F	9 ± 1°F	9 ± 1°F	
	5 ton		-	9 ± 1°F	9 ± 1°F	-	-	

System Optimization

Refrigerant Leak Test

- In this mode sensor will trigger an alarm all components will shut down and the blower will turn on.
- If you have a Zone Accessory board, ensure all the zone dampers open and any accessories turn off.

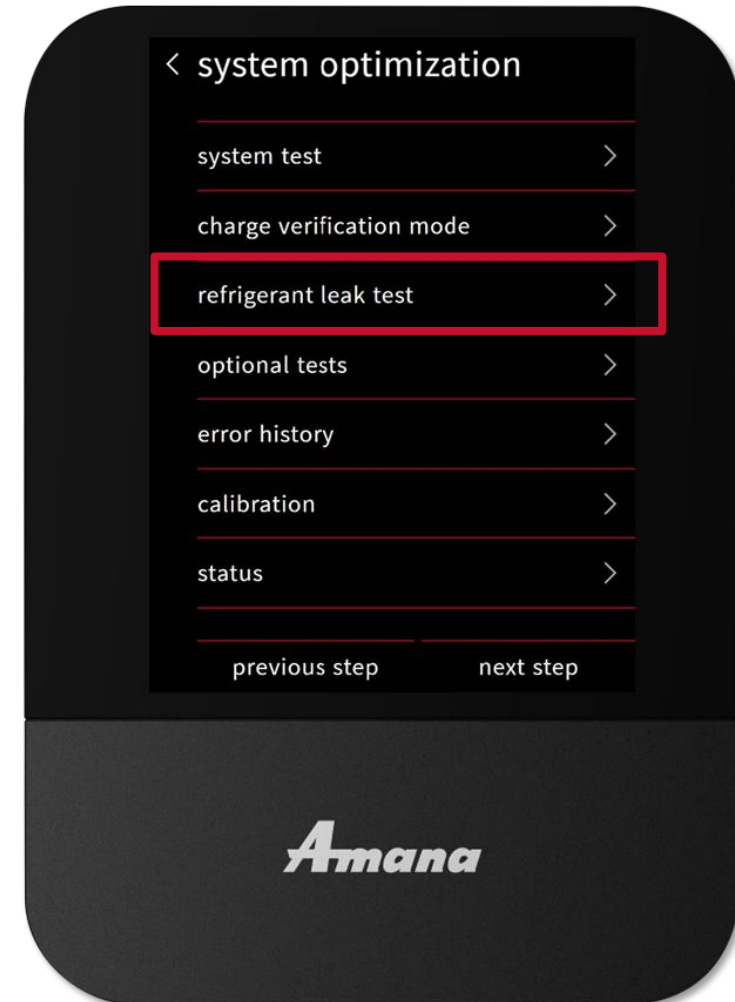

System Optimization

Error History

- The error history menu stores errors from most recent to least recent.
 - Each error entry includes an error code.
 - A timestamp along with the equipment type that generated the error, and a brief error description is displayed.

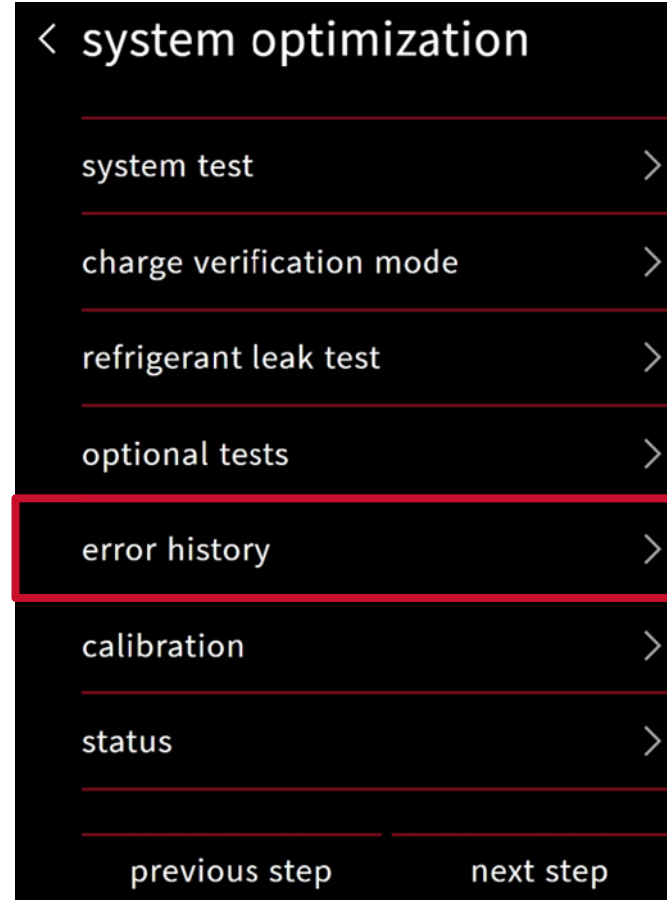

Status Screen

Status

- The status menu displays data pertaining to the selected equipment.
- The scrollable list can be accessed any time by returning to the installer set-up screen.

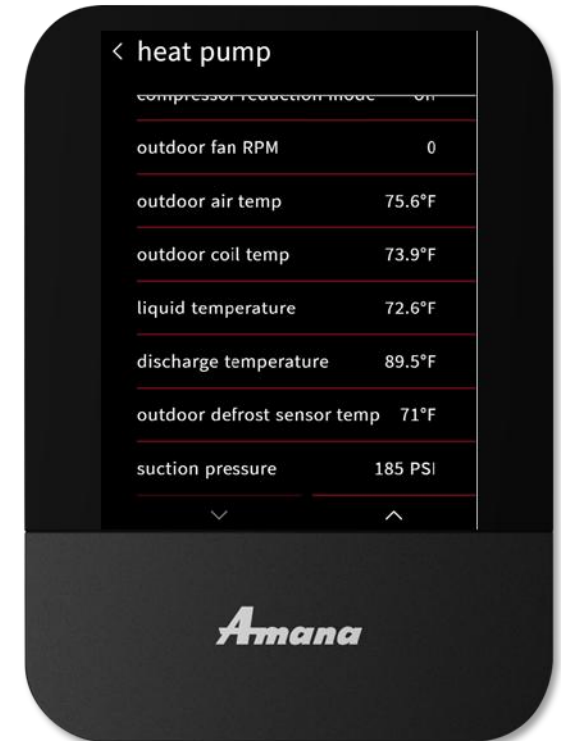
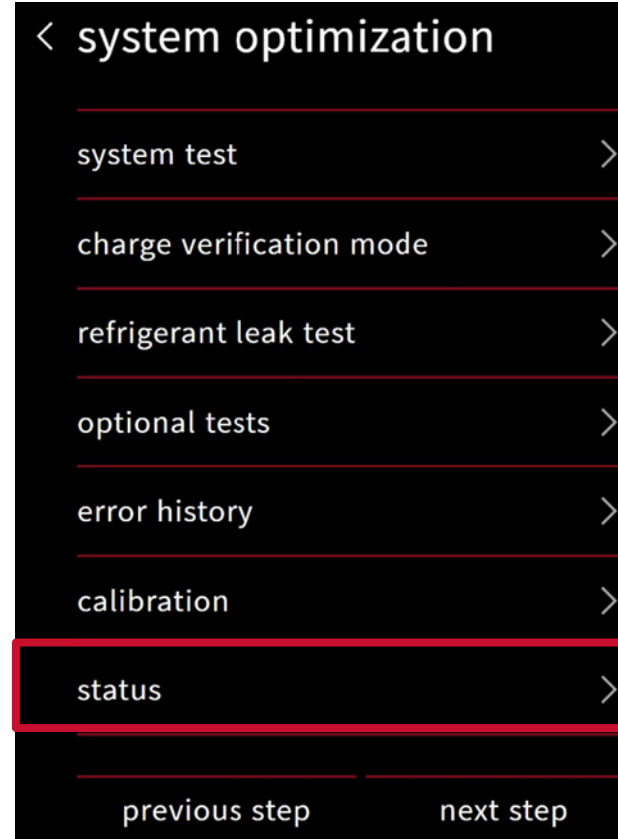

Deadband/Overcool

- The overcool value is overlaid on the dead band, increasing the range to maintain the minimum cool heat differential of at least 2 degrees.
- It is recommended to set at least 1 degree of overcool for dehumidification purposes.

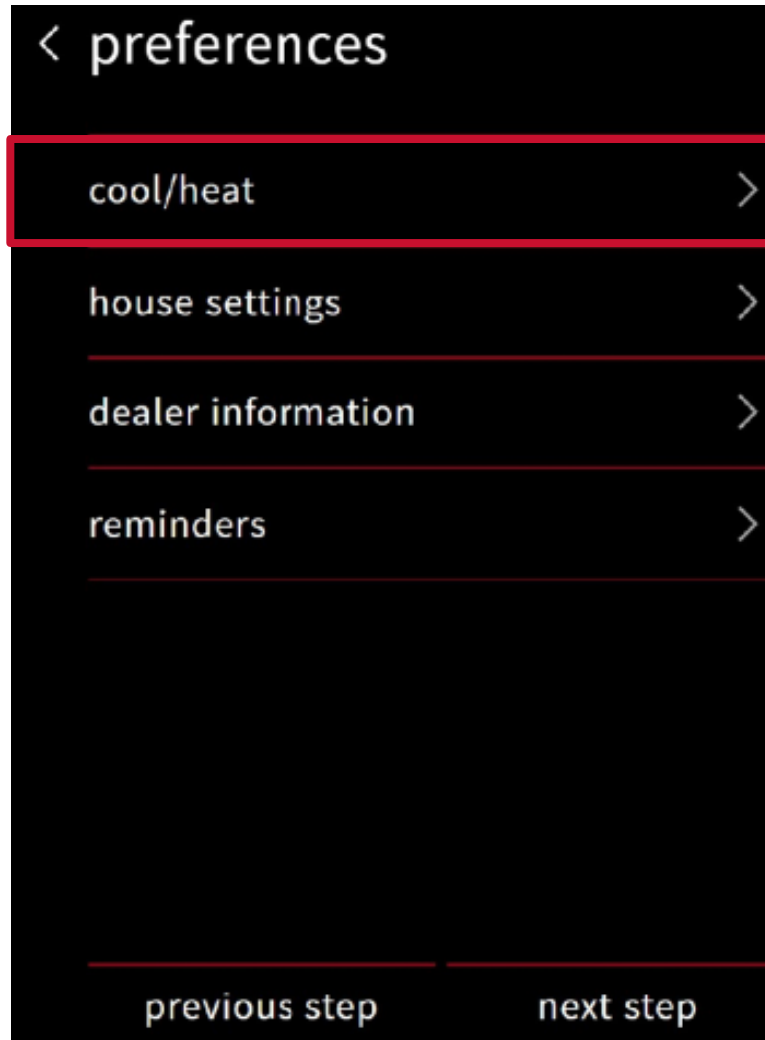

Powerful Heating Mode

- POWERFUL HEATING enables the system to increase supply air temperature when demand is low to satisfy comfort. This mode decreases indoor CFM and may increase compressor speed.
- **NOTE:** POWERFUL HEATING MODE is OFF by default. Can be activated through the thermostat user menu.

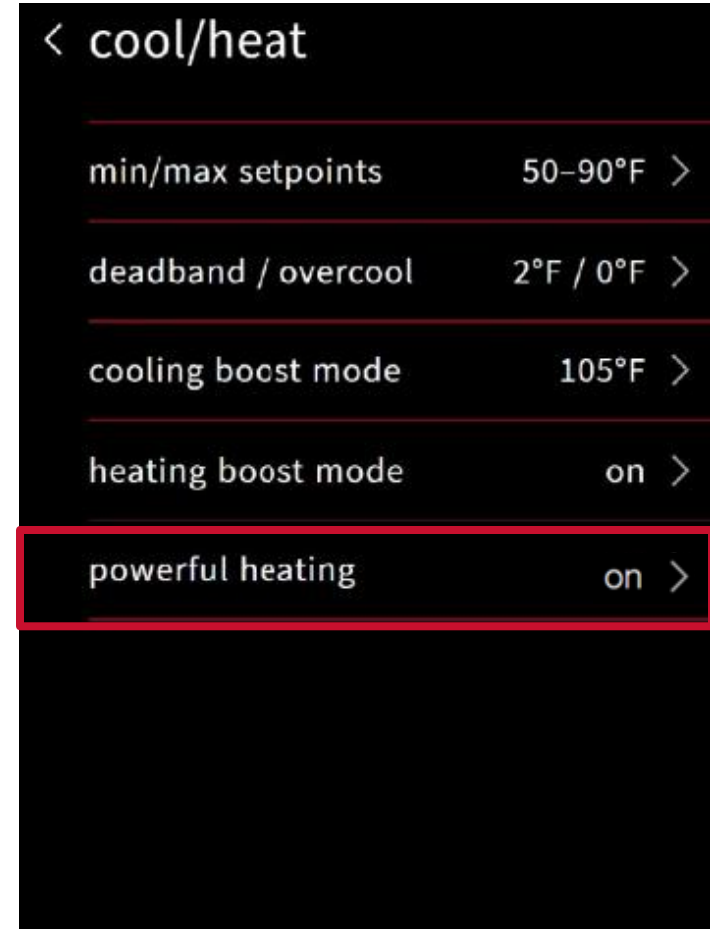
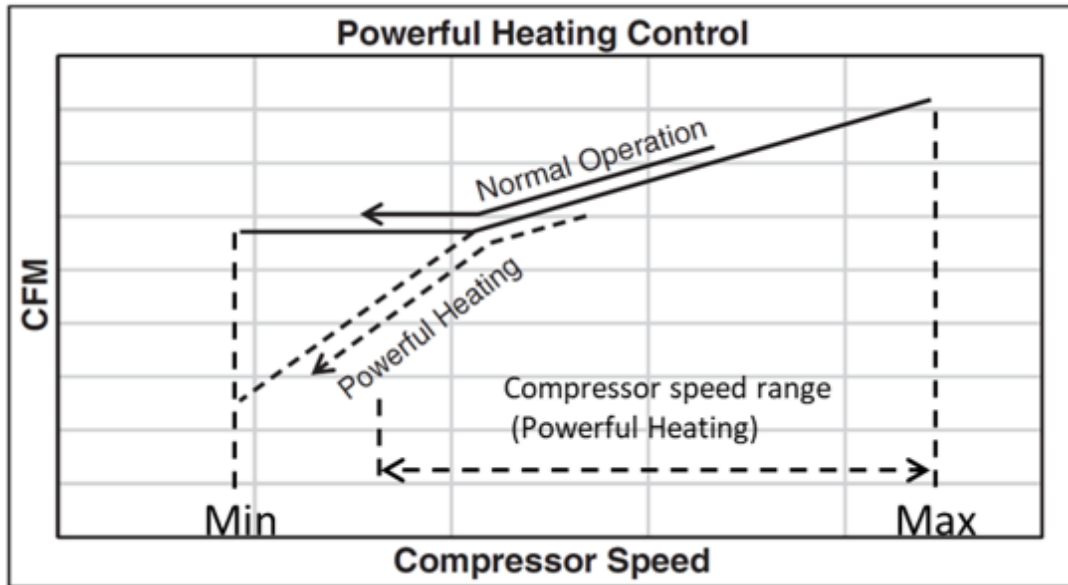

Preferences

Boost Mode

- Boost mode allows the compressor to operate at a higher RPS (Revolution Per Second) than factory maximum.
 - Max. RPS value is hard coded into the software and cannot be changed.
- Cooling boost mode outdoor activation temperature can be adjusted in the boost mode menu.
 - Boost mode will operate after the ambient temperature increases beyond the selected activation temperature and the compressor has achieved its max RPS.
- Heating boost mode is enabled/disabled by selecting On/Off.
- On thermostats you may select the max. RPS offset.
 - This allows you to adjust ± 10 RPS from the factory max. RPS

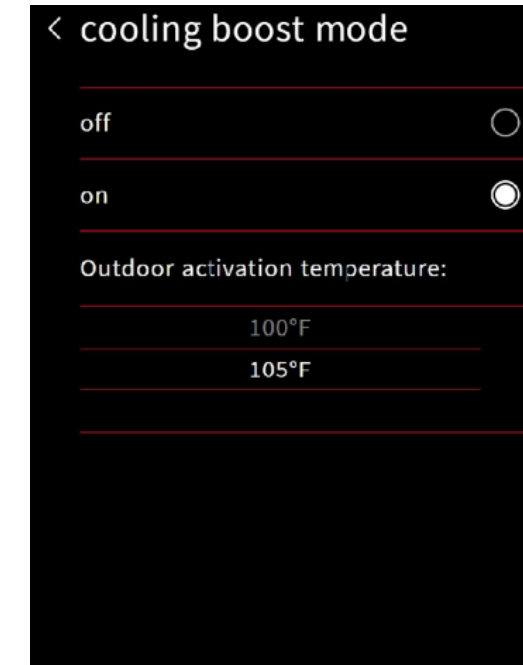

Checking Duct Static

- Refer to your rating plate for the maximum (ESP) external static pressure.
- Incorrect external static pressure may cause
 - Excessive temperature rise
 - Motor stress
 - Duct stress
 - Reduced performance
 - Unwanted condensation
 - etc.

FROM SEA LEVEL
DU NIVEAU DE LA MER

MODEL NO. AMVS800603BNAA
NO. DE MODELE
SERIAL NO. 1711465141
NO. DE SERIE

AHRI CERTIFIED
www.ahridirectory.org

POWER SUPPLY 115 VOLTS 1PHASE 60 HERTZ LESS THAN 12 AMPS.
CARACTERISTIQUES ELECTRONICS MOINS DE 12 AMPS.

	NATURAL GAS		L.P. GAS	
	HI	LO	HI	LO
HEATING INPUT (BTU/HR) DEBIT (BTU/HRE.)	60,000	42,000	60,000	42,000
OUTPUT CAPACITY (BTU/HR) PUISSANCE (BTU/HRE.)	48,000	33,600	48,000	33,600
FOR TEMPERATURE RISE OF (°F) ELEVATION DE TEMP. DE L'AIR	20 - 50		20 - 50	

DESIGN MAX. OUTLET TEMP. (°F) 150 LIMIT SET (°F) 140
TEMPERATURE MAX. DE L'AIR A LA SORTIE (°F) REGLAGE DE LIMITEUR (°F)

FACTORY TESTED EXTERNAL STATIC PRESSURE (IN. W.C.) .5
PRESSION STATIQUE VERIFIE A L'USINE (PO. C. D'EAU)

MOTOR (H.P.) 3/4 BLOWER (IN.) 10x8
MOTEUR SOUFFLEUR (PO.)

AUX. LIMIT SETTING (°F) 120 NOx EMISSION LIMIT — ng/J

	NAT. GAS	L.P. GAS
MAXIMUM GAS SUPPLY PRESSURE TO FURNACE (IN. W.C.) PRESSION DU GAZ A L'ENTREE MAXIMUM (PO.C.D'EAU)	7	14
MINIMUM GAS SUPPLY PRESSURE FOR PURPOSE OF INPUT ADJUSTMENT (IN. W.C.) PRESSION DU GAZ A L'ENTREE POUR L'OBJET D'AJUSTAGE (PO.C.D'EAU)	5	11
MANIFOLD PRESSURE (IN. W.C.) PRESSION TUBULURE (PO.C.D'EAU)	3.5	10
MAIN BURNER ORIFICE SIZE INJECTEUR DE BRULEAUR PRINCIPAL	45	55

ANSI Z21.47b/CSA2.3b 2006

GAS—FIRED GRAVITY & FORCED AIR CENTRAL FURNACES STANDARD
ACCEPTED FOR USE, CITY OF NEW YORK, MEA

ETL
LISTED
Intertek
3073027

Checking Duct Static

- The positive static is measured
 - **Furnace:**
 - At the supply outlet and must be read between the furnace and the cooling coil.
 - **Air handler/MBVK:**
 - At the supply outlet.
- The negative static is measured
 - **Furnace:**
 - At the return plenum and must be read between furnace the and filter.
 - **Air handler:**
 - At the return plenum and must be read between air hander and the filter.
 - **MBVK:**
 - Between the modular blower and the cased coil

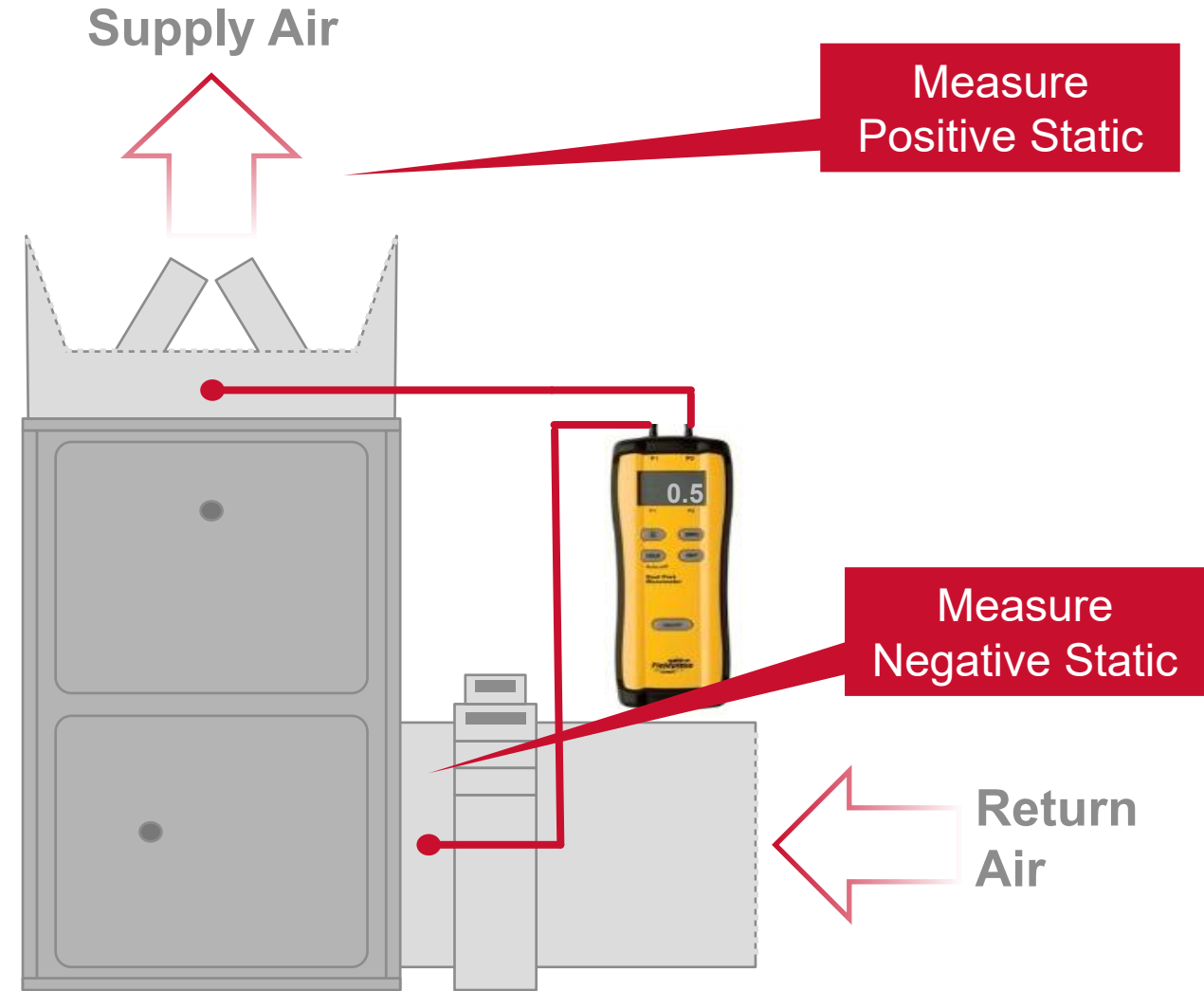

Caution: Do not damage components within cased coil.

Static Pressure | Gas Furnace and AC Coil

- The design static of most furnaces is 0.5 inches water column.
- Use a manometer to measure the static pressure of the furnace only.
 - Supply side is measured between the heat exchanger and evaporator coil.
 - Return side is measured between the blower wheel and filter.

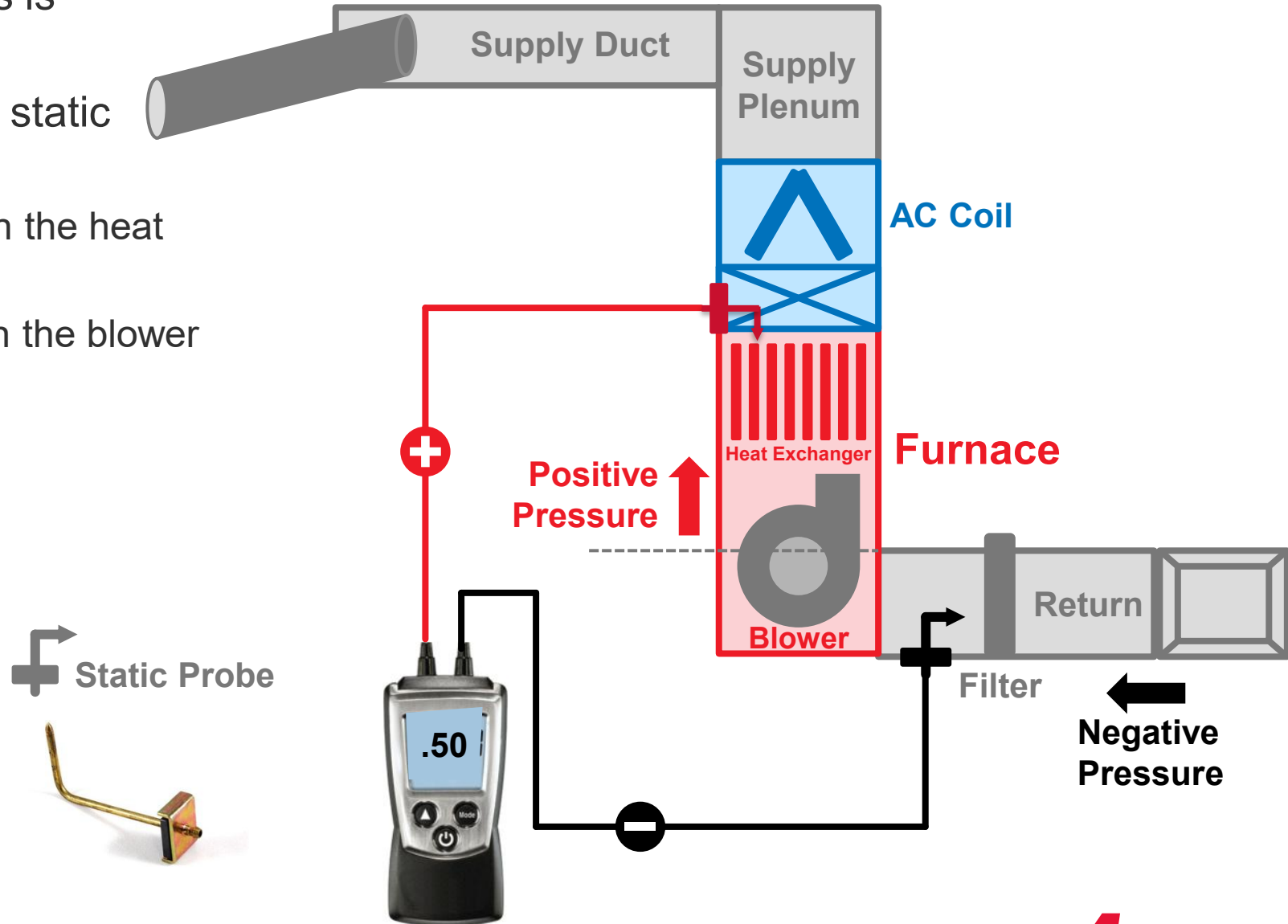

Static Pressure | Single Piece Air Handler

- On a single piece air handler, the evaporator coil has been installed at the factory and is already considered in static pressure calculation.
- Use a manometer to measure the static pressure of the air handler only.
 - Measure static pressure of the supply duct at the outlet of the air handler.
 - Measure the static pressure of the return duct at the inlet of the air handler.

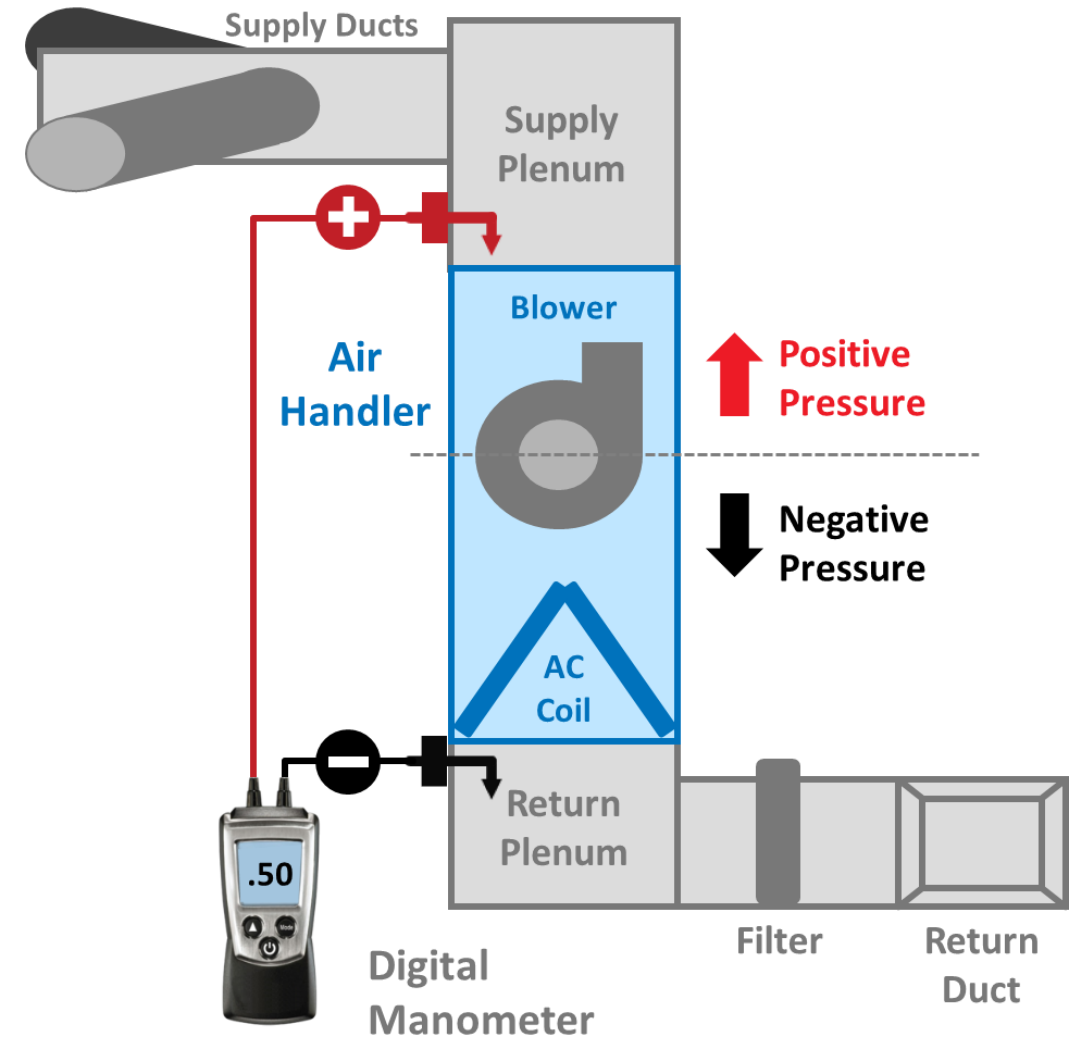

Static Pressure | Two Piece Air Handler

- On a two-piece air handler, the evaporator coil is not part of the air handler so it must be not considered in calculating the static pressure.
- Use a manometer to measure the static pressure of the air handler's blower assembly only.
 - Measure the static pressure of the supply duct at the outlet of the unit.
 - Measure the static pressure between the outlet of the evaporator coil and the inlet of the air handler.

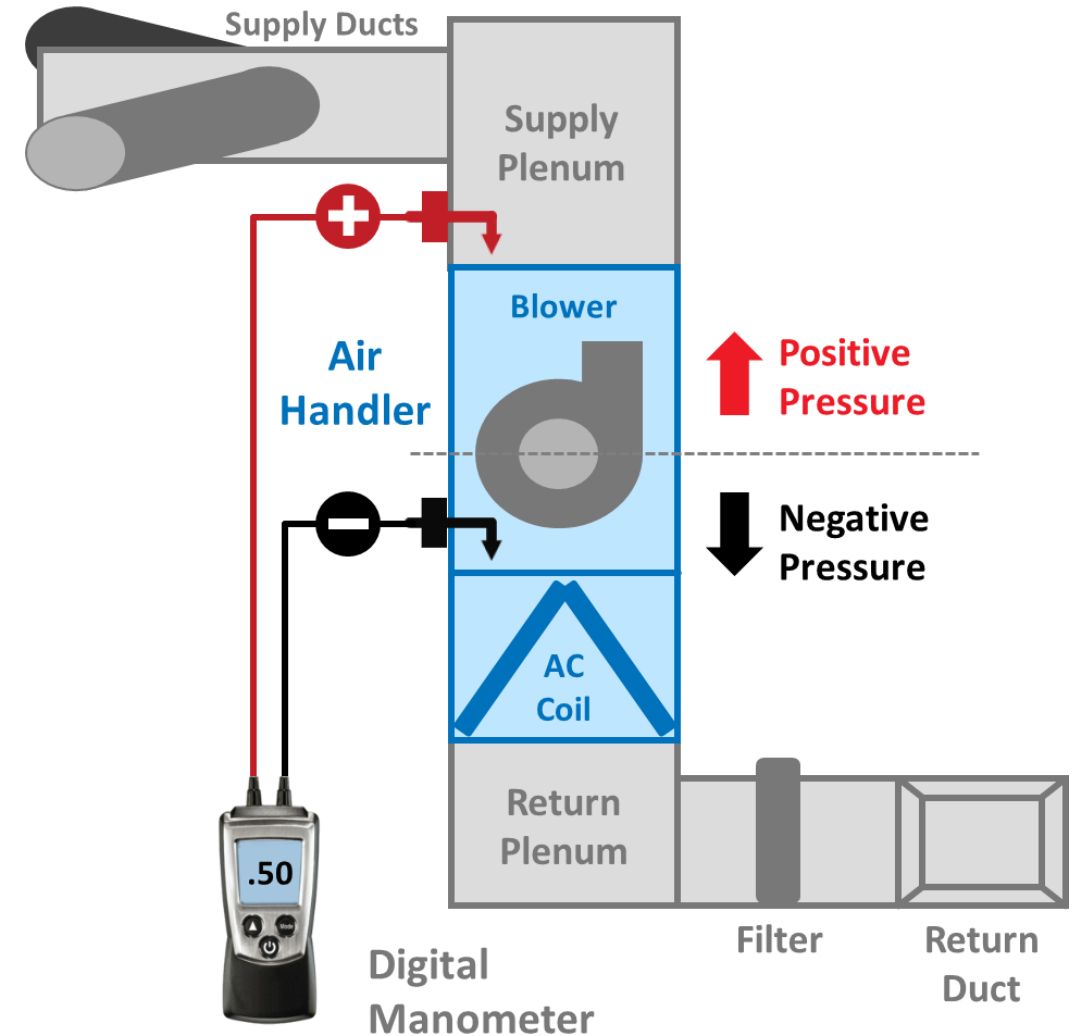

Static Pressure | Problems Caused By High Static

- Problems resulting from high static pressure
 - Reduced Airflow
 - Limit / pressure switch tripping
 - Long term will shorten life of:
 - Compressor
 - Heat Exchanger
 - Motors
 - Components

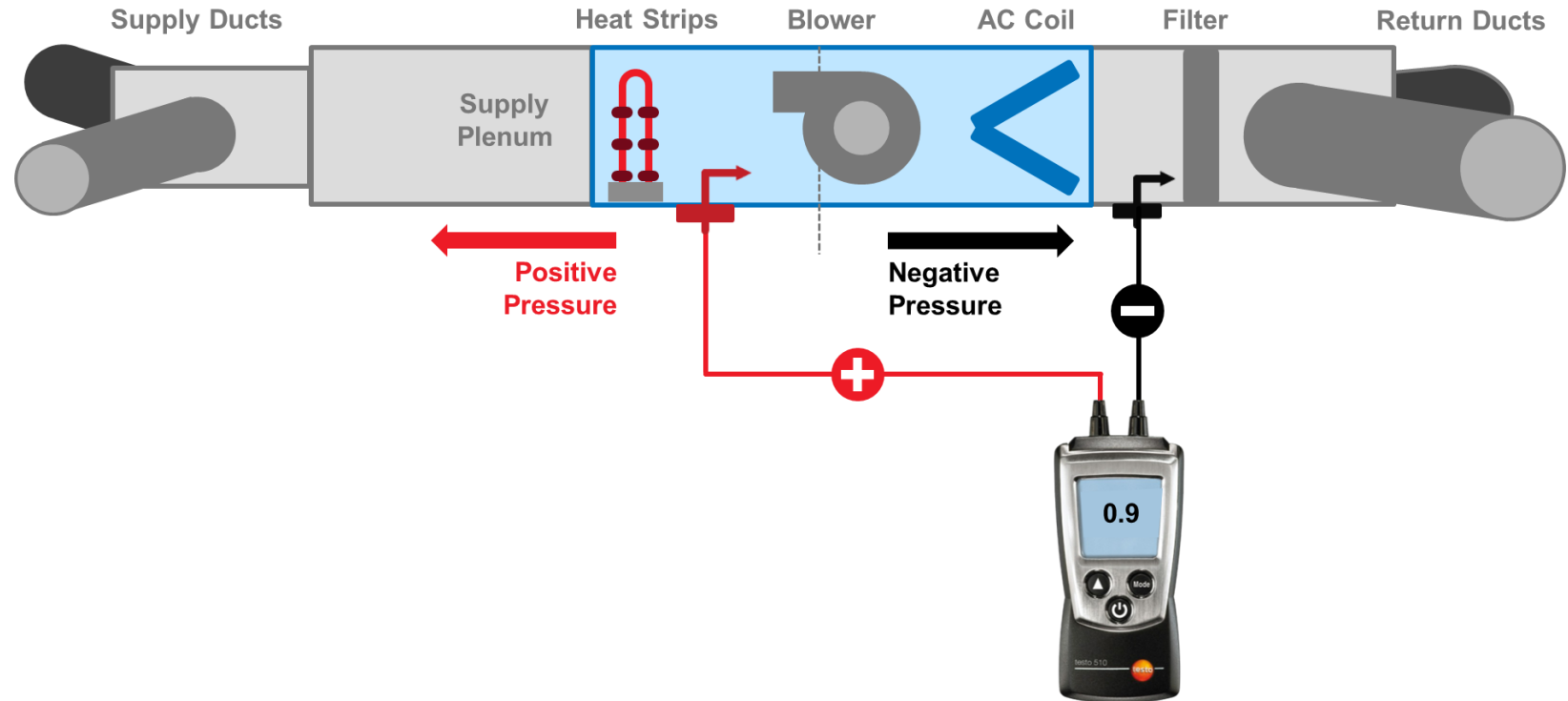

Testing for Pressure Drop | Individual Components

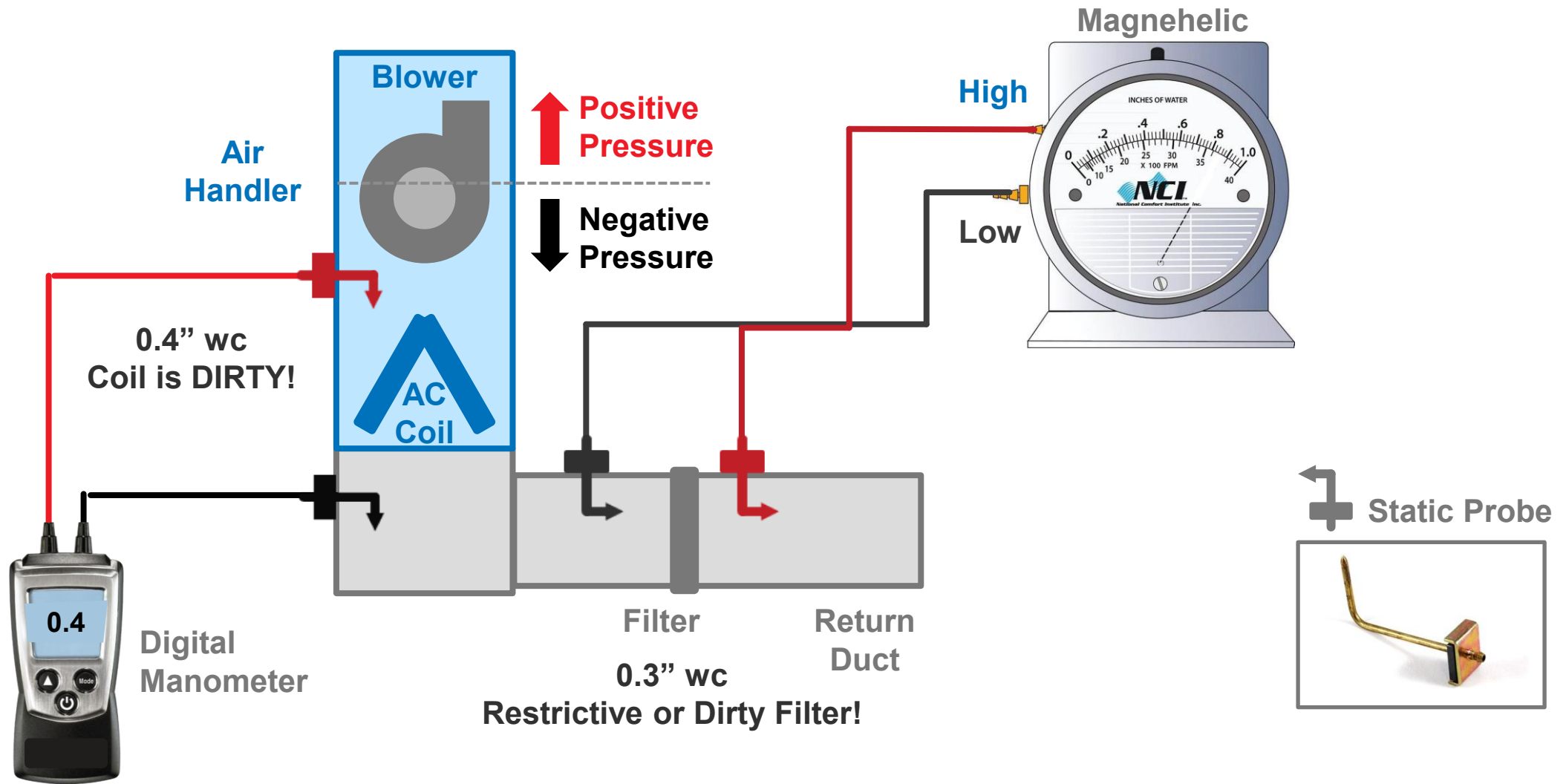

Start-Up Checklist for the Amana S-Series System

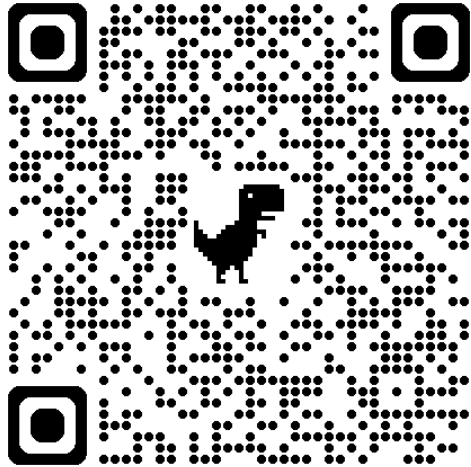

DAIKIN COMFORT TECHNOLOGIES NORTH AMERICA, INC.



R-32 AMANA S-series STARTUP CHECKLIST

IMPORTANT NOTE: This Checklist does not supersede or substitute for other technical documentation such as Service Manuals, Installation Manuals/Installation Instructions, and/or Operation Manuals, but can be used in conjunction with such documentation. When servicing or maintaining inverter equipment, you should observe all warnings and cautions contained in such documentation.

WARNING
ONLY PERSONNEL THAT HAVE BEEN TRAINED TO INSTALL, ADJUST, SERVICE OR REPAIR (HEREINAFTER, "SERVICE") THE EQUIPMENT SPECIFIED IN THIS MANUAL SHOULD SERVICE THE EQUIPMENT. THE MANUFACTURER WILL NOT BE RESPONSIBLE FOR ANY INJURY OR PROPERTY DAMAGE ARISING FROM IMPROPER SERVICE OR SERVICE PROCEDURES. IF YOU SERVICE THIS UNIT, YOU ASSUME RESPONSIBILITY FOR ANY INJURY OR PROPERTY DAMAGE WHICH MAY RESULT. IN ADDITION, IN JURISDICTIONS THAT REQUIRE ONE OR MORE LICENSES TO SERVICE THE EQUIPMENT SPECIFIED IN THIS MANUAL, ONLY LICENSED PERSONNEL SHOULD SERVICE THE EQUIPMENT. IMPROPER INSTALLATION, ADJUSTMENT, SERVICING OR REPAIR OF THE EQUIPMENT SPECIFIED IN THIS MANUAL, OR ATTEMPTING TO INSTALL, ADJUST, SERVICE OR REPAIR THE EQUIPMENT SPECIFIED IN THIS MANUAL WITHOUT PROPER TRAINING MAY RESULT IN PRODUCT DAMAGE, PROPERTY DAMAGE, PERSONAL INJURY OR DEATH.

WARNING
DO NOT BYPASS SAFETY DEVICES

General Information & Safety Considerations

- Daikin strongly recommends that any individual installing, commissioning or servicing any Daikin inverter system, should first receive comprehensive training at a factory training facility or factory authorized training facility.
- **IMPORTANT NOTE:** This Checklist does not supersede or substitute for other technical documentation such as Service Manuals, Installation Manuals/Installation Instructions, and/or Operation Manuals, but can be used in conjunction with such documentation. When servicing or maintaining inverter equipment, you should observe all warnings and cautions contained in such documentation.
- It is recommended that only personnel trained to service Daikin inverter equipment perform maintenance work.
- Always follow local codes.
- Refrigerant gas is heavier than air and displaces oxygen. A leak can result in oxygen displacement.
- Be sure to disconnect the power cable before disassembling the equipment for repair. Follow OSHA lock out tag out procedures.
- Working on equipment that is connected to the power supply may cause an electrical shock. If it is necessary to supply power to the equipment to conduct the repair or inspection of circuits, do not touch any electrically charged sections of the equipment.
- Do not allow the discharging refrigerant to come in contact with skin as it may cause frostbite.
- If disconnecting the suction or discharge pipes of the compressor, recover the refrigerant completely, and cut the piping using a tubing cutter. NEVER unbrazed a brazed joint! If there is refrigerant remaining inside the compressor, the refrigerant or compressor oil may discharge at a high temperature and pressure, possibly causing injury.

Amana® is a registered trademark of Maytag Corporation or its related companies and is used under license. All rights reserved.



Our continuing commitment to quality products may mean a change in specifications without notice.
© 2022 DAIKIN COMFORT TECHNOLOGIES MANUFACTURING, L.P. • Houston, Texas • USA • www.daikincomfort.com or www.daikinac.com

1

Rev. 09/17/23

DAIKIN COMFORT TECHNOLOGIES NORTH AMERICA, INC.



R-32 Amana S-series Startup Checklist

HOMEOWNER'S INFORMATION

Today's Date: _____
Homeowner Name: _____
Address: _____
City: _____ State: _____ Zip: _____ Phone: _____
Home Sq. Ft.: _____ Single or Multi-Story _____ Year Home Built: _____

CONTRACTOR'S INFORMATION

Contractor's Name: _____ Tech's Name: _____
Address: _____
City: _____ State: _____ Zip: _____ Phone: _____

DISTRIBUTOR'S INFORMATION

Distributor: _____ Service Manager: _____
Address: _____
City: _____ State: _____ Zip: _____ Phone: _____

EQUIPMENT INFORMATION

Outdoor Unit Model: _____ Serial: _____
Coil Model: _____ Serial: _____
Air Handler/Furnace Model: _____ Serial: _____
Heater Kit Model: _____
Thermostat: _____ Software Version: _____
DKN #: _____
Installation Date: _____ Filter (Type, Size, Number): _____
Previous Unit Installed: _____

Manual J: Yes NO Manual S: Yes NO Manual D: Yes NO

Published by Daikin Technical Services. Daikin products are subject to continuous improvements. Daikin reserves the right to modify product design, specification, and information in this publication without notice and without incurring any obligation.

2

Daikin Comfort Technologies Manufacturing, Inc.
19001 Kierulff Road, Wylie, TX 75094
713.861.2500 | www.DaikinComfort.com



Dealer Edit

- Navigating to Dealer Edit Will Allow you to access or revisit the installer set-up screen.

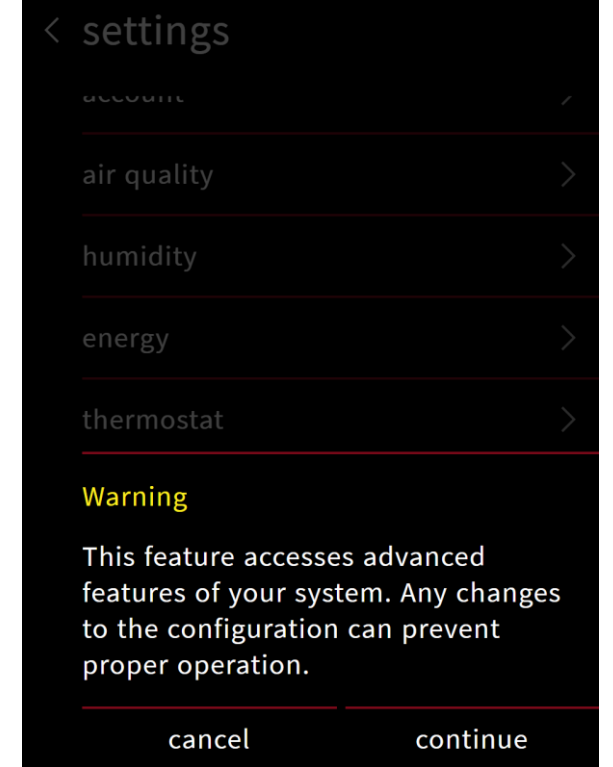
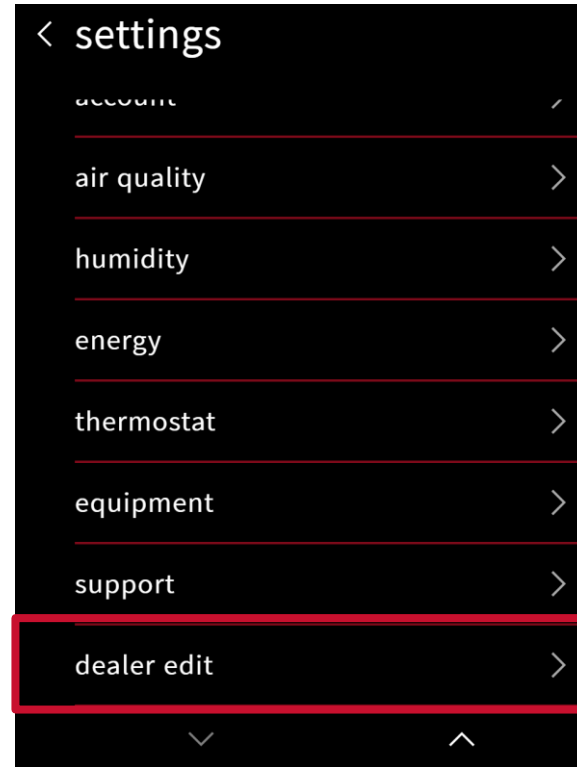
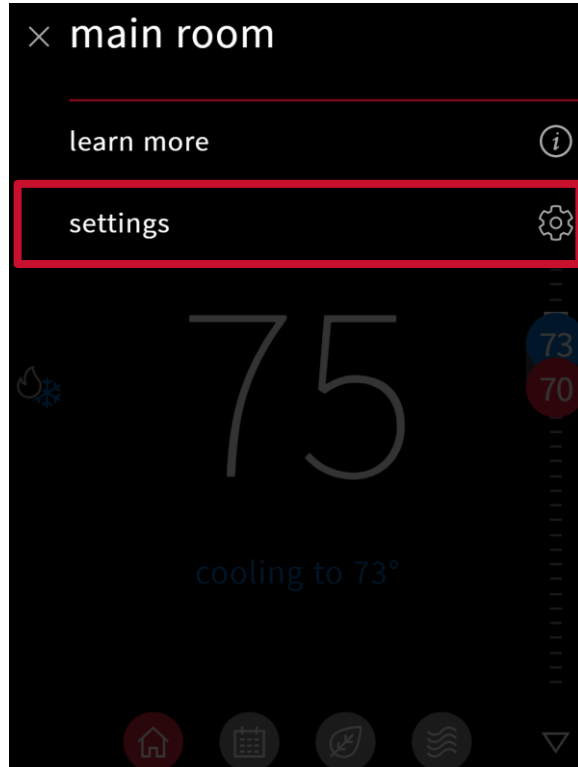
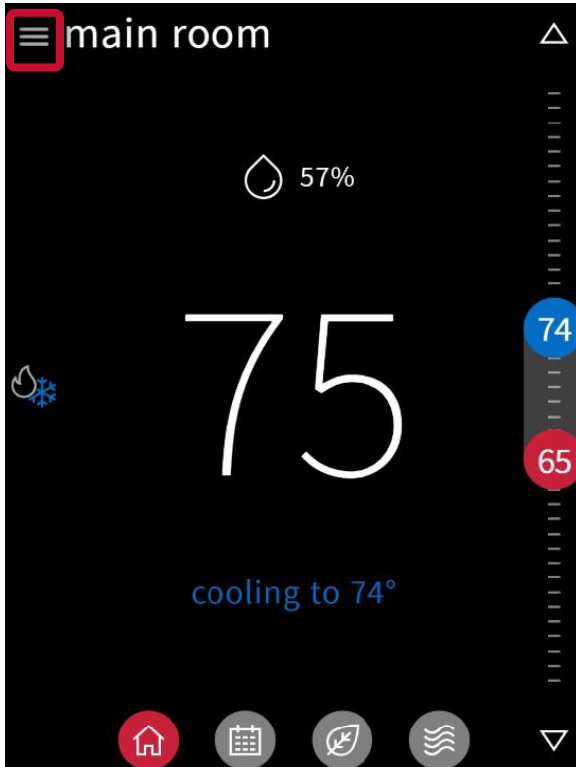

Dealer Navigation

- Acknowledging the prompt enables you to tap the learn more icon in the top right corner.
- The icon displays the installer code, giving you access to the installer set-up screens.

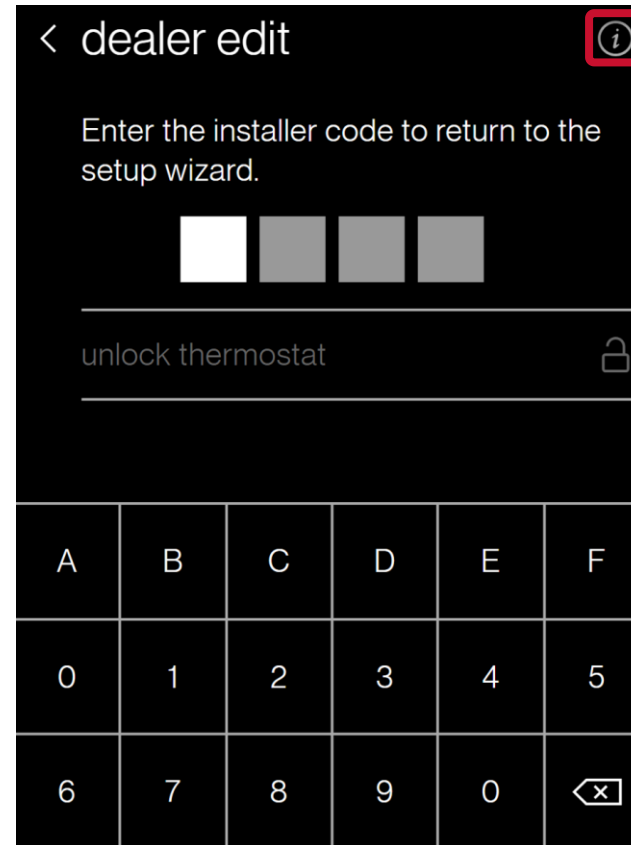

Cased Coils

Amana R-32 S-Series Installation and Commissioning
Technical Training Module TRV-15.3

R32



Rest assured.
It's an Amana® brand.



© 2024 Daikin Comfort Technologies North America, Inc.
Amana® is a registered trademark of Maytag Corporation or its related companies and is used under license.
All rights reserved.



Agenda

Installation

Additional Transformer for PCB
Control Panel and Wiring

Horizontal Right and Left Installations (front view)

- The CHPEA coil is bi-directional and can be installed in either a left or right direction.
- CHPEA coils are designed for indoor installation only and are installed on the discharge air side of a furnace.
- They should be installed on the return air side of a modular blower.

Note: The coil must be installed with the line set and drain openings to the front of the furnace or modular blower.



Horizontal Right



Horizontal Left

Installation

90 Plus Furnace Install Procedures

$\frac{1}{2}$ " to $\frac{3}{4}$ " tilt



Level end-to-end



Duct Flange Attachment

- There is no conversion required to reverse from a right to left application.
- Attach the duct flanges to the discharge side of the unit.
- If the coil and furnace combination are not similar in depth and width, use a field-supplied transition to center the furnace and coil openings.

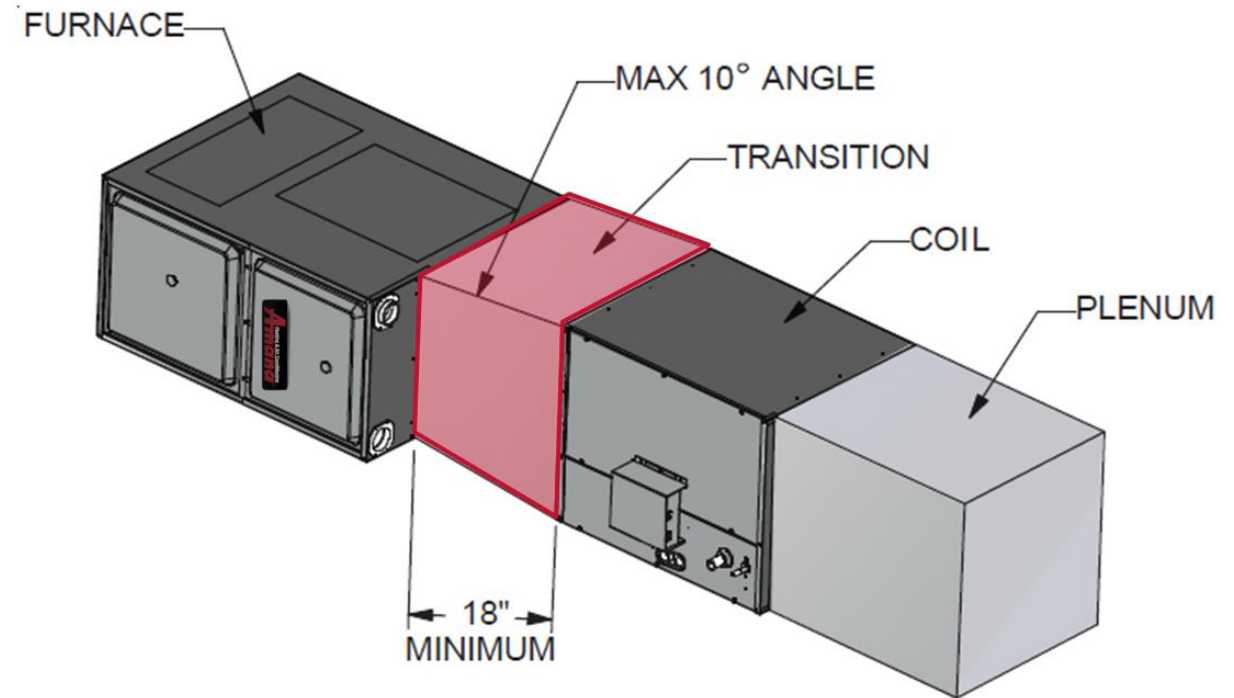

Z-Bracket Attachment

- The supplied Z-bracket attachment should be used to attach the coil to a narrower furnace, when a furnace is one size smaller than the coil.

Example: Coil height is 21.0" and furnace width is 17.5".

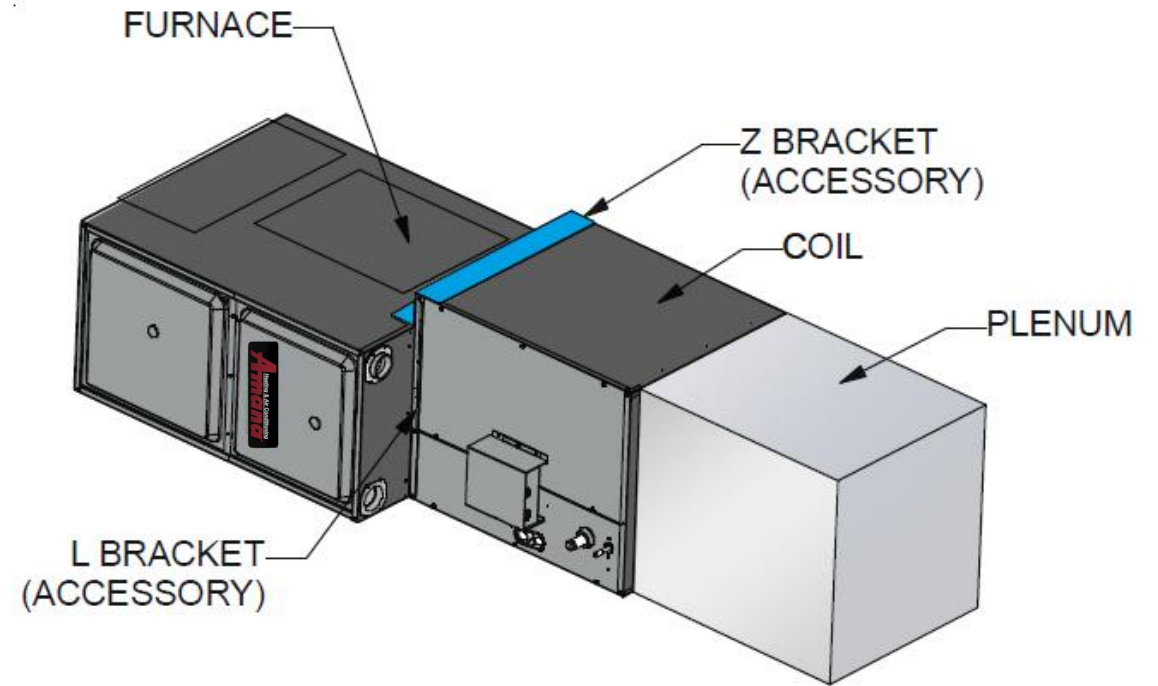
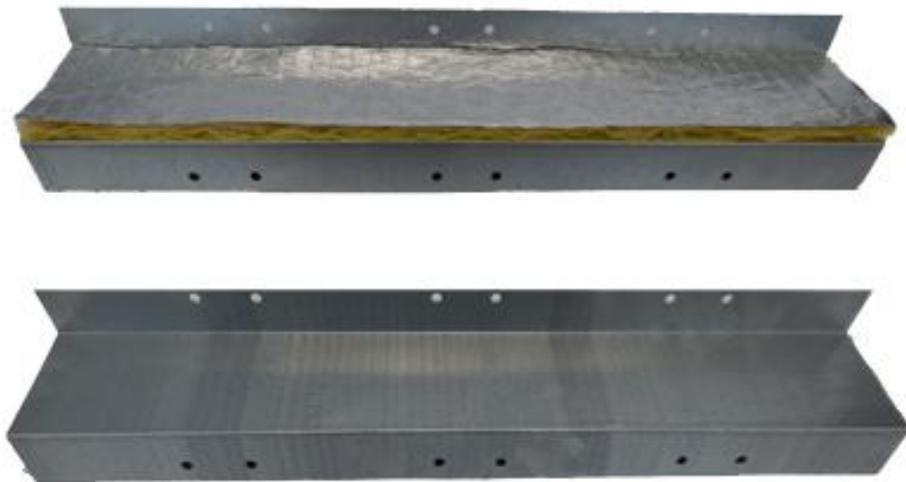

(Z-BRACKET WITH NARROW FURNACE)

Installation

Z-bracket Hardware and Bracket Kit

- Using the hardware and brackets provided, attach the coil to the furnace and plenum to the coil.

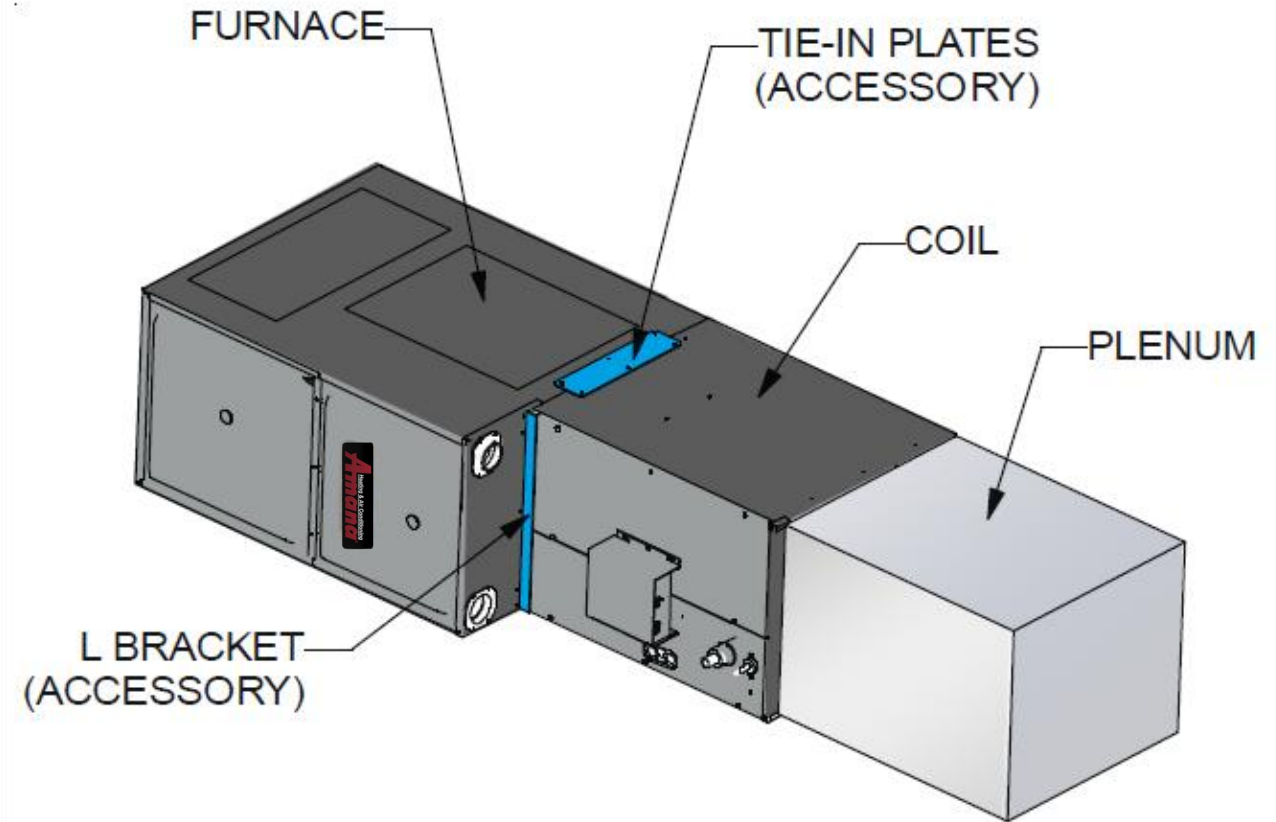
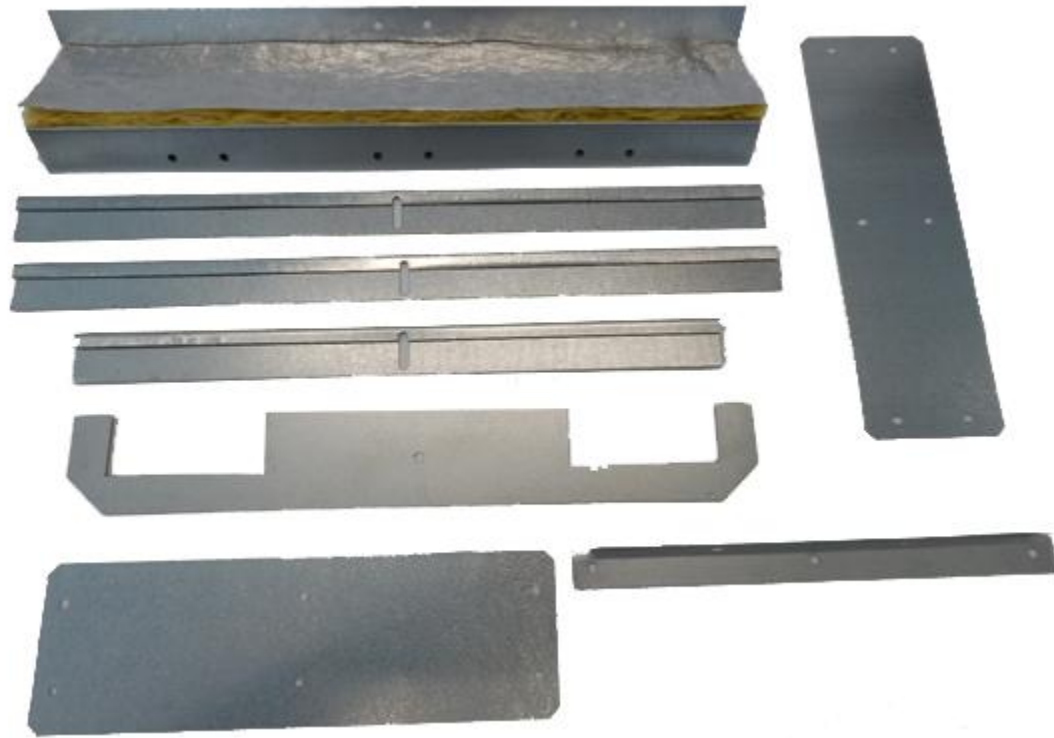

Installation

Stiffening/Shipping Bracket Removal

- Prior to installation, remove the stiffening (shipping) bracket spanning the A-coil apex to the rear of the wrapper on all models.
- The bottom duct flange for the supply plenum side is shipped unattached.
- Carefully insert the flange into bottom rail and use a 5/16" screw to attach at the middle of the flange.
- Secure the side flanges with field procured 5/16" screws on the supply plenum side.

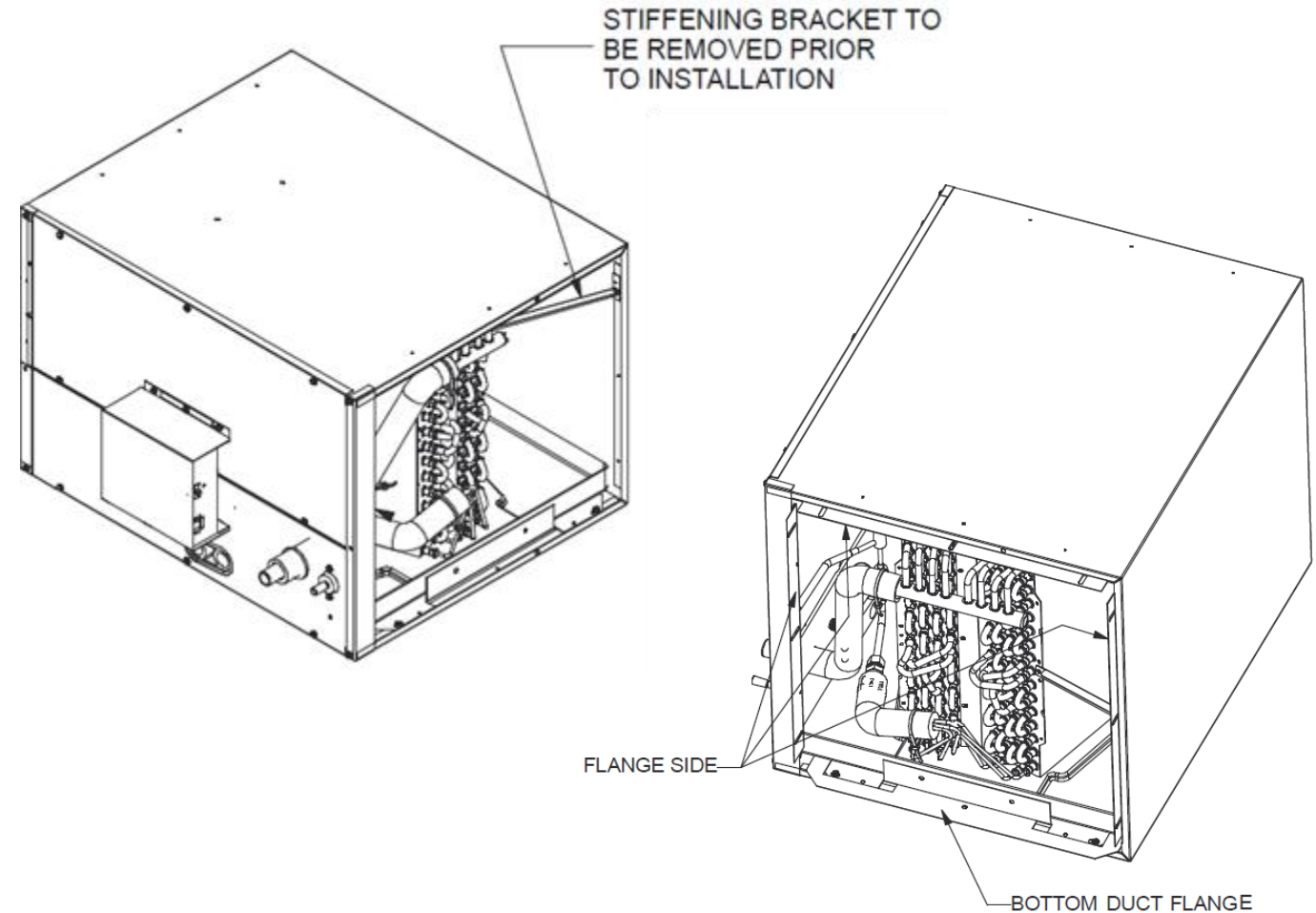

Installation

Sealing Along the Panel Gap

- If the plenum and furnace openings are the same size, the filler plates must be removed.

Note: Apply field provided insulation tape along all joining surfaces to prevent cabinet sweating.

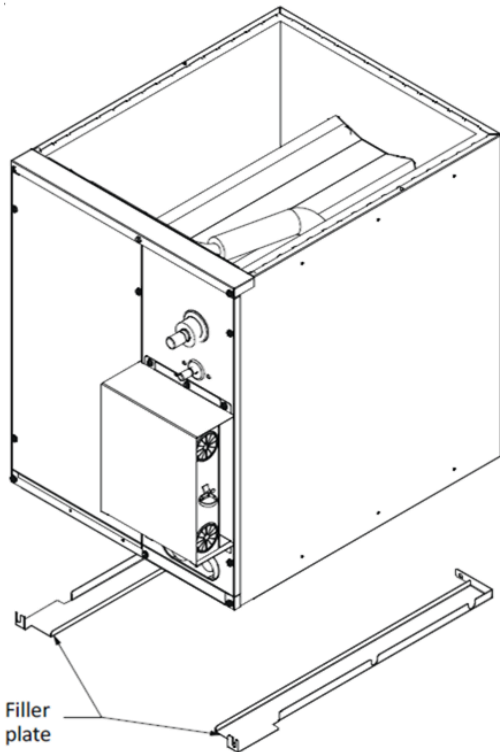

	CAPEA1818B	CAPEA1818C			
	CAPEA2422B	CAPEA2422C	CAPEA2422D	CAPE4860C	CAPE4860D
Cased Coil	CAPEA3026B	CAPEA3026C	CAPEA3026D	CAPE4961C	CAPE4961D
Kit Model	DPICX-BB	DPICX-CB	DPICX-DB	DPICX-CA	DPICX-DA

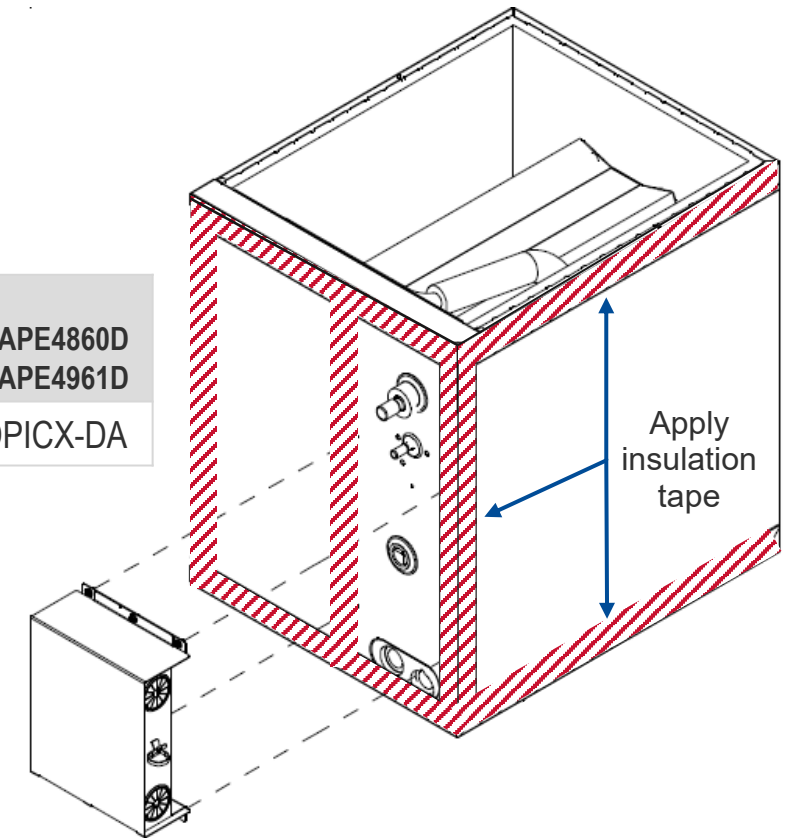

Installation

Removing Control Panel

- Remove control panel from the right front panel to prevent component wiring damage.
- Removing the control panel allows the wiring to be safely pushed through the panel wire-way.

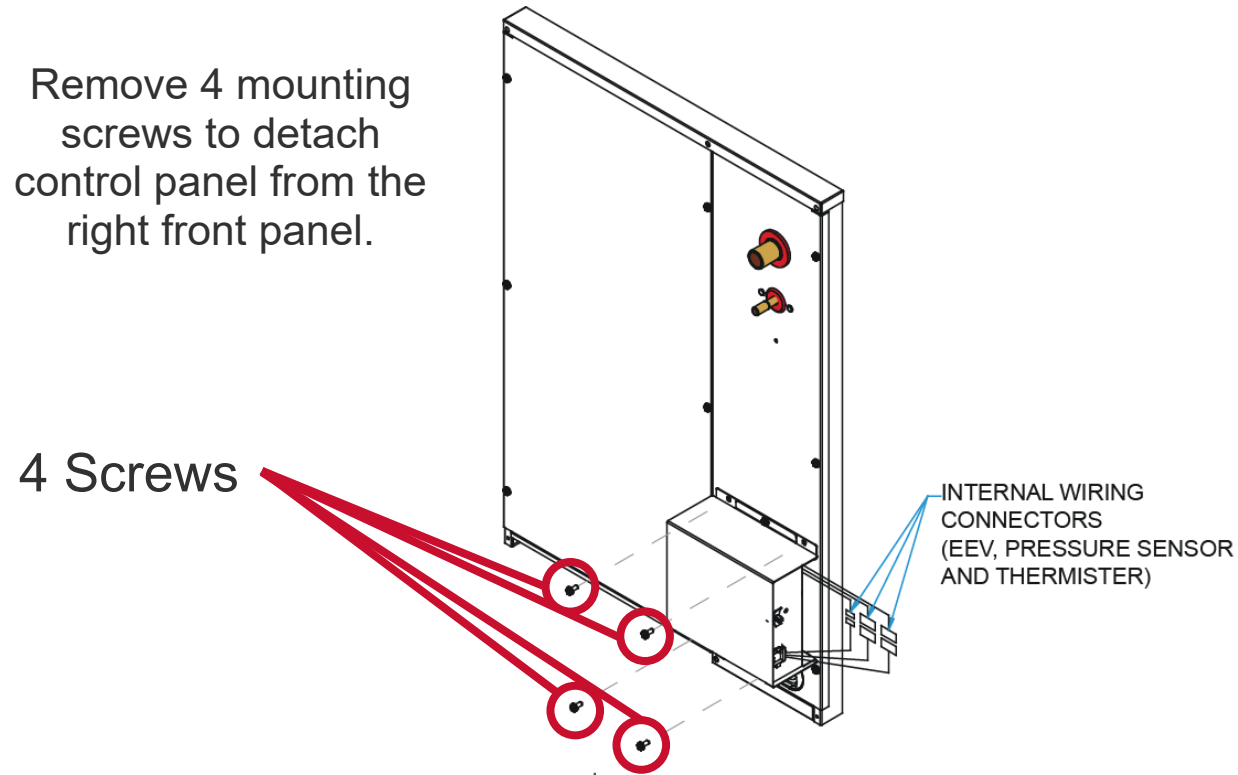

Release of Factory Nitrogen from Shipping

- A cased coil is shipped containing nitrogen gas under 150 psig.
- Release pressure from the gas piping pressure release device before initiating piping work.

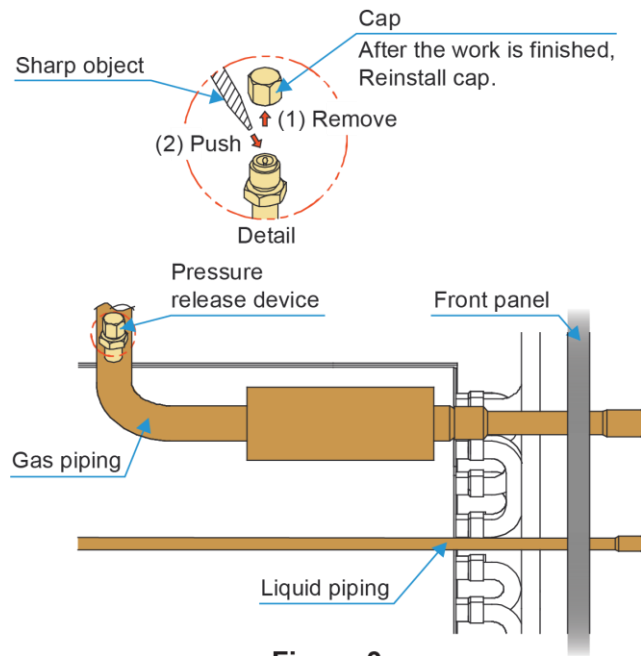
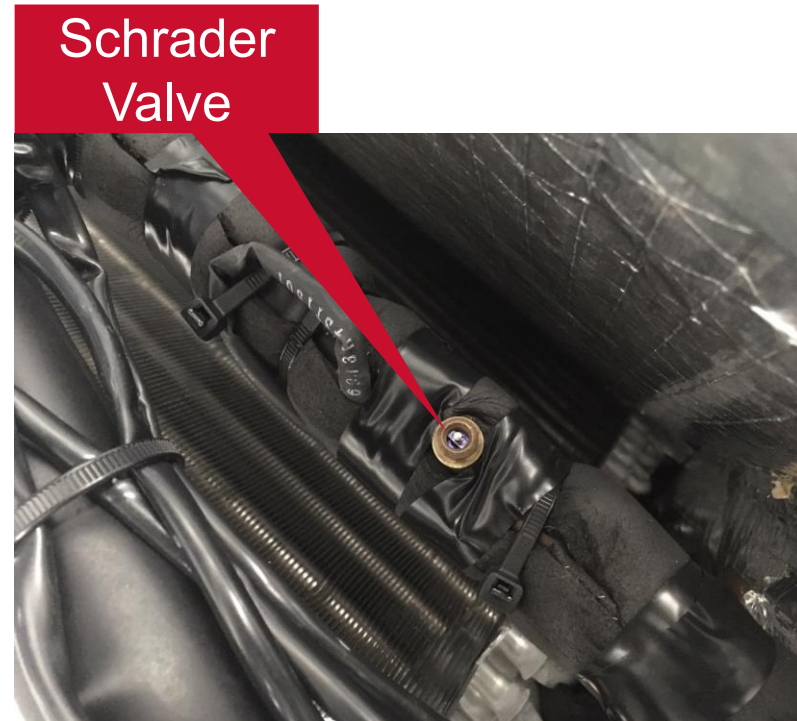
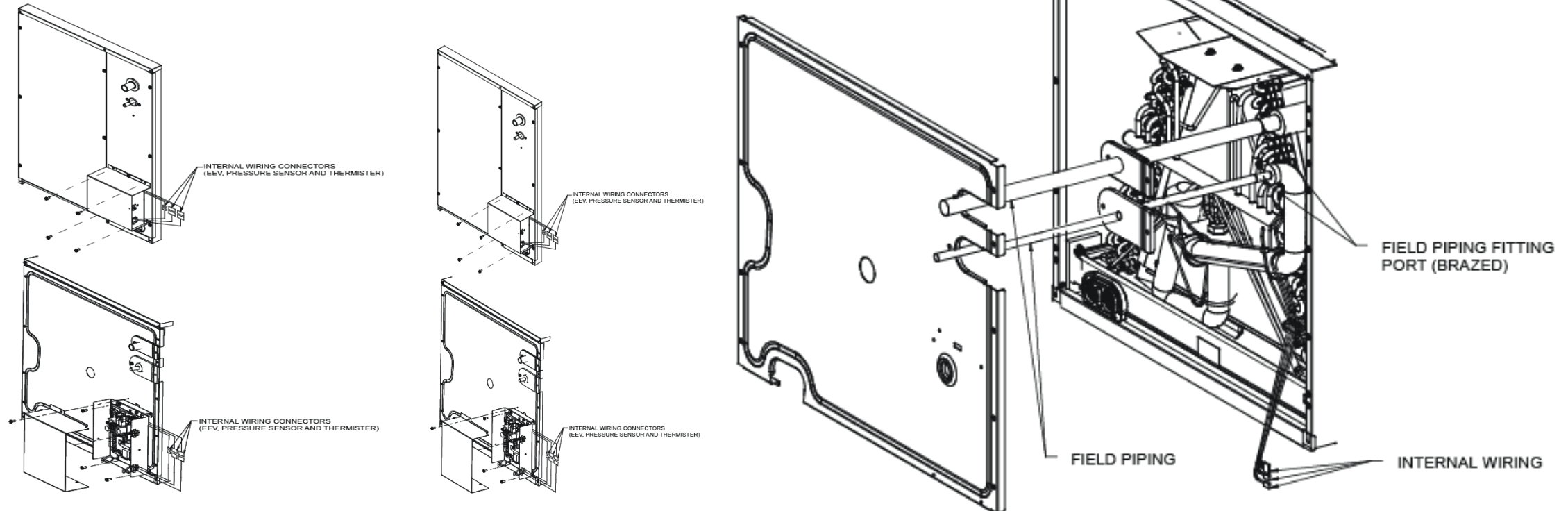

Figure 3



Brazing

- When brazing the indoor coil, make sure to protect the pipe going into the coil by wrapping with a wet cloth.
- This will protect heat from transferring to the pipe and damaging the sensors on the indoor coil piping.



Drain Piping

- A secondary (port B) condensate drain connection is provided for areas where local codes require it.

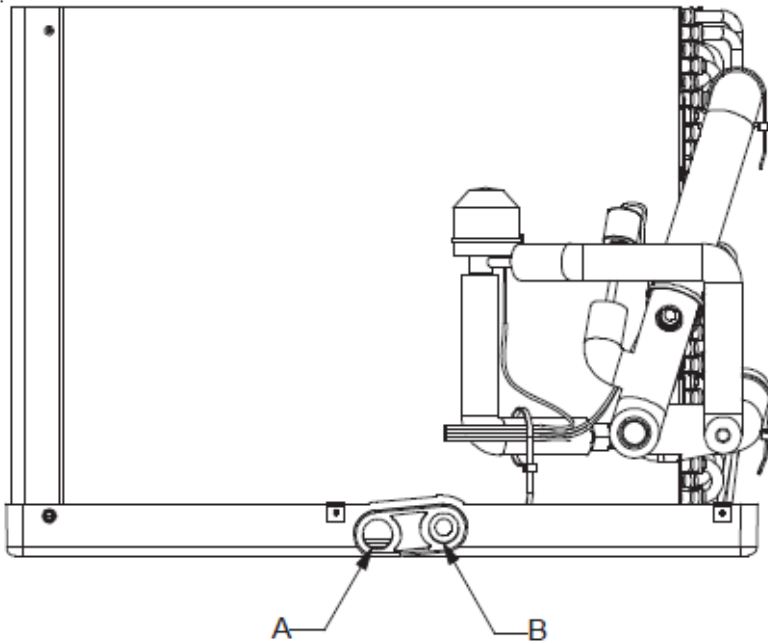

Port B

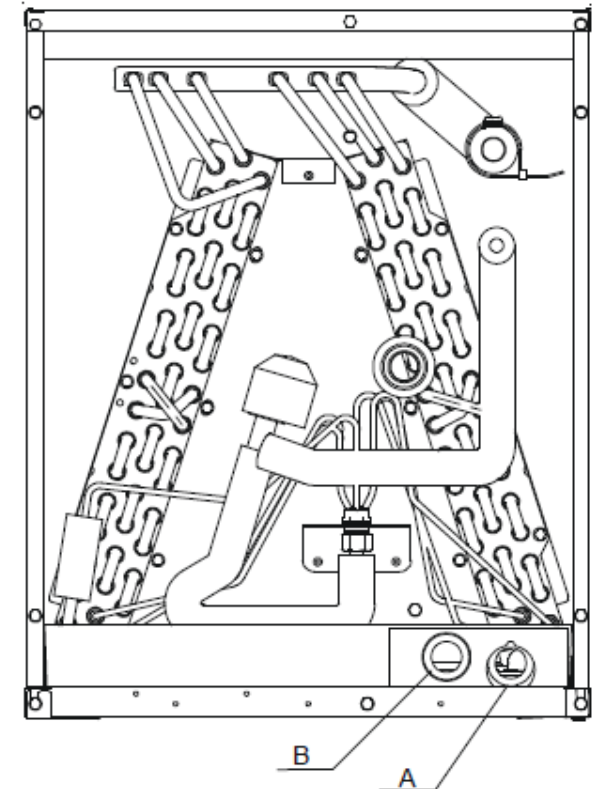

Drain Piping

- In a blow-through application the drain trap prevents conditioned air from escaping.
 - The depth of a running trap should be either 1" or a depth that permits unrestricted condensate drainage without excessive air discharge.
 - It is permissible in this application to use a shallow trap design, referred to as a running trap.
- In a draw-through application the drain trap prevents air from being drawn back through the drain line during fan operation.
 - This prevents condensation from draining and if connected to a sewer line, prevents sewer gases from being drawn into the airstream during blower operation.

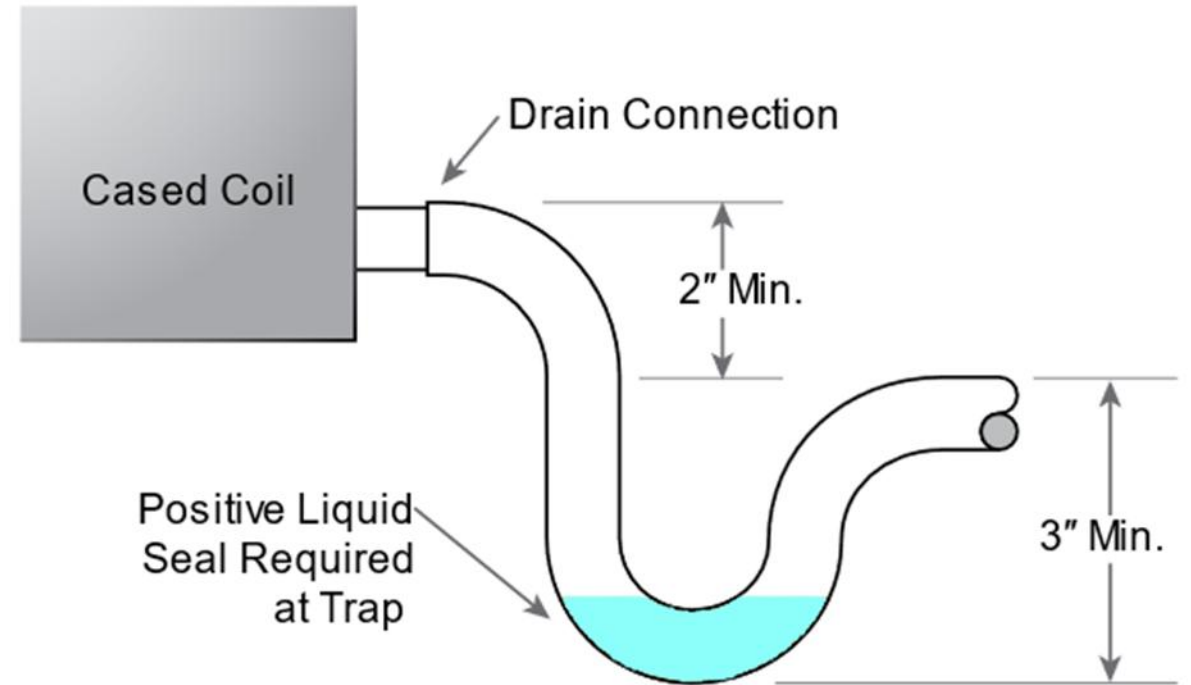

Agenda

Installation

Additional Transformer for PCB

Control Panel and Wiring

Additional Transformer to Power Cased Coil Control Panel/PCB

- A transformer is shipped with the EEV coil and will be mounted in the gas furnace and MBVK.
- The purpose of this transformer is to power the printed circuit board on the EEV coil.
- The kit includes two (2) brackets that allow the transformer to be installed inside the furnace cabinet. (brackets are labeled A and B)
- The install instructions that come with the EEV coil show the proper way to mount the transformer.

	Model Name	Cabinet Width	Bracket B	No Bracket
Gas Furnace	Upflow 80%	All	X	
	Upflow 96%	All	X	
	Upflow 97%	All	X	
	Upflow 80% + 96% ULN	All	X	
	Upflow 80%	All		X
	Upflow 96%	All	X	
	Upflow 97%	17.5"		X
	Upflow 97%	21.0"	X	
	Downflow 80% + 96% ULN	All		X
Modular Blower	MBVK*	All		X

Transformer Installation

Mounting bracket 'A' Inside of Furnace

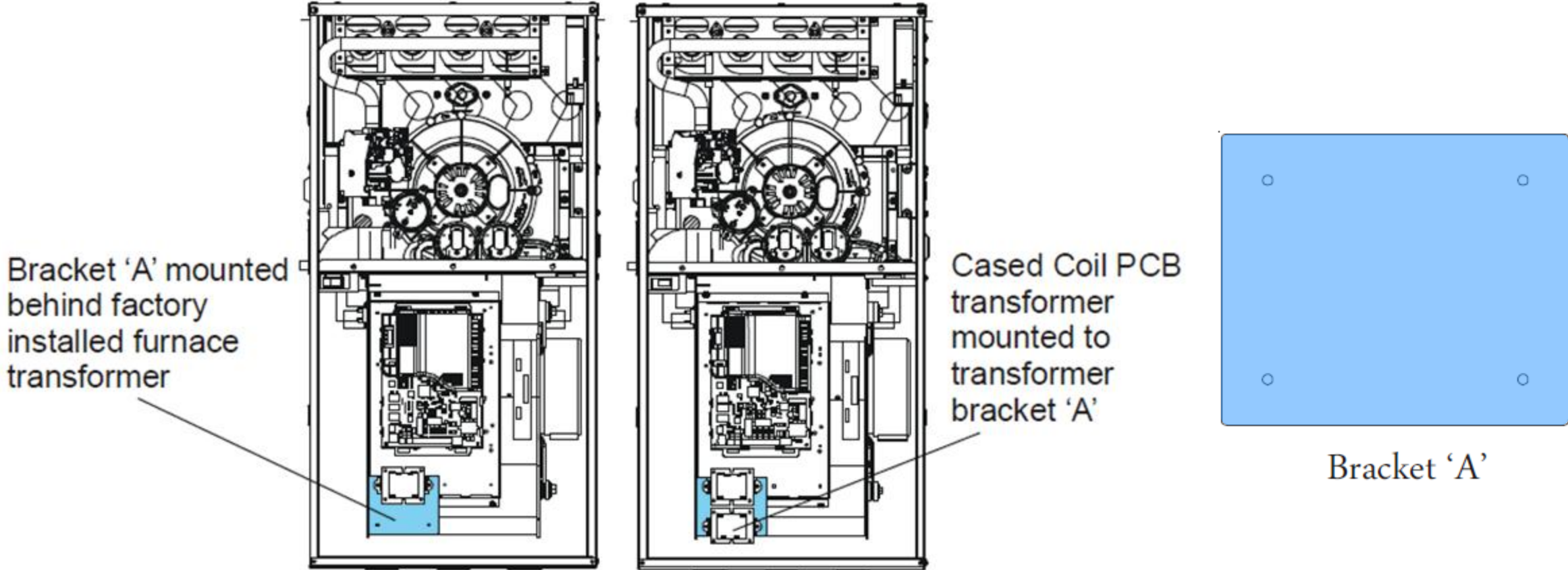

Transformer Installation

Mounting Bracket 'B' Inside of Furnace

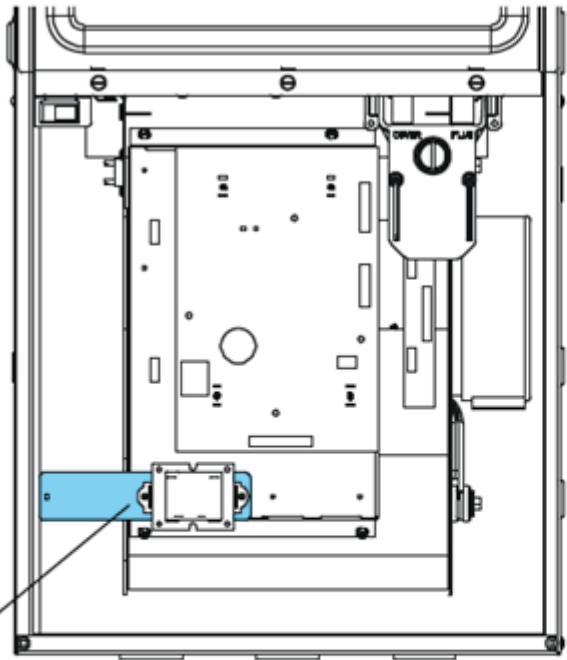

Bracket 'B' mounted behind factory installed furnace transformer

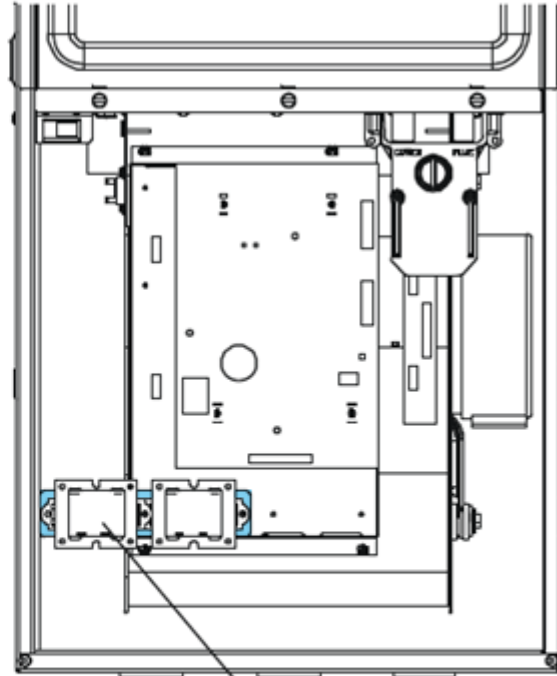

Cased Coil transformer PCB mounted to transformer Bracket 'B'



Bracket 'B'

Transformer Installation

Wiring PCB Transformer Using Furnace Power

- Use the red and black wires provided in the transformer kit.
- Connect one end of the red and black wires to the high voltage side of the transformer. (COM and 120VAC)
- Connect the other end of the red and black wires to the power source in the furnace high voltage junction box.

Optional: Communicating furnace PCB's have line voltage accessory terminals that will allow the transformer to be powered from the furnace board. (if not being used)

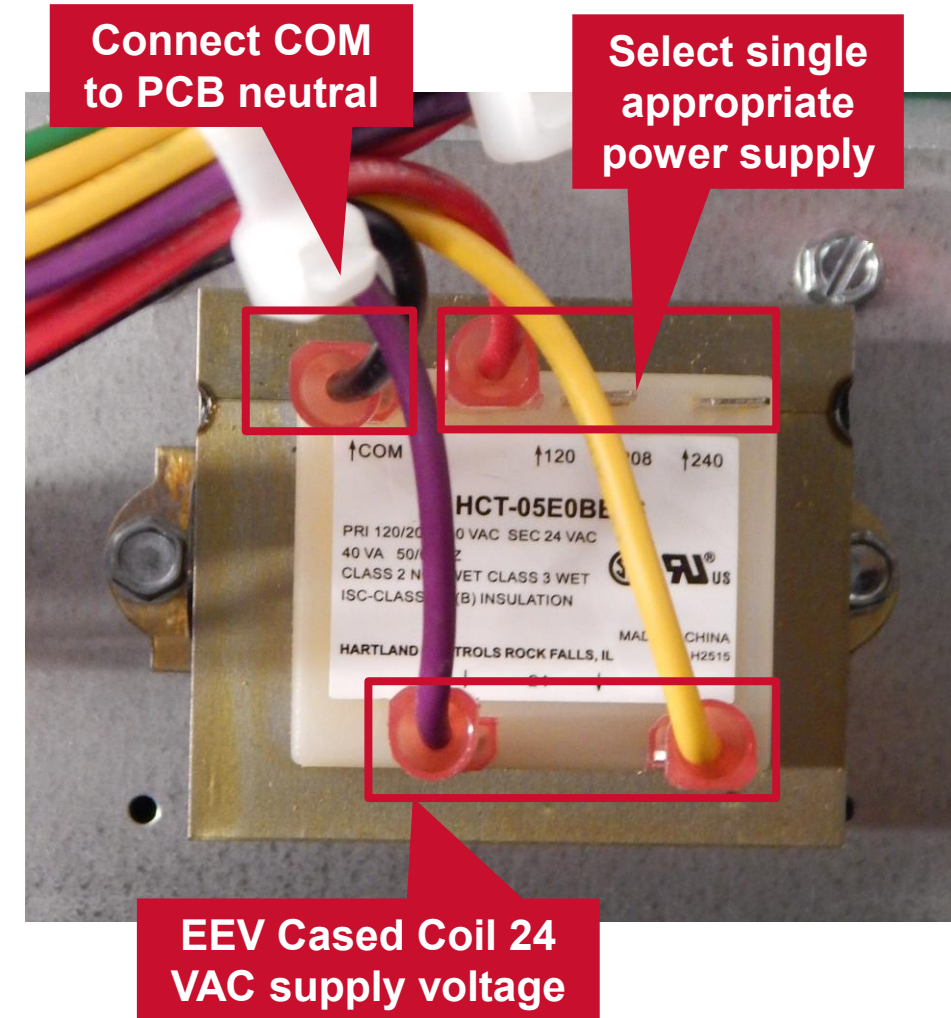

Transformer Wiring Using Furnace Power

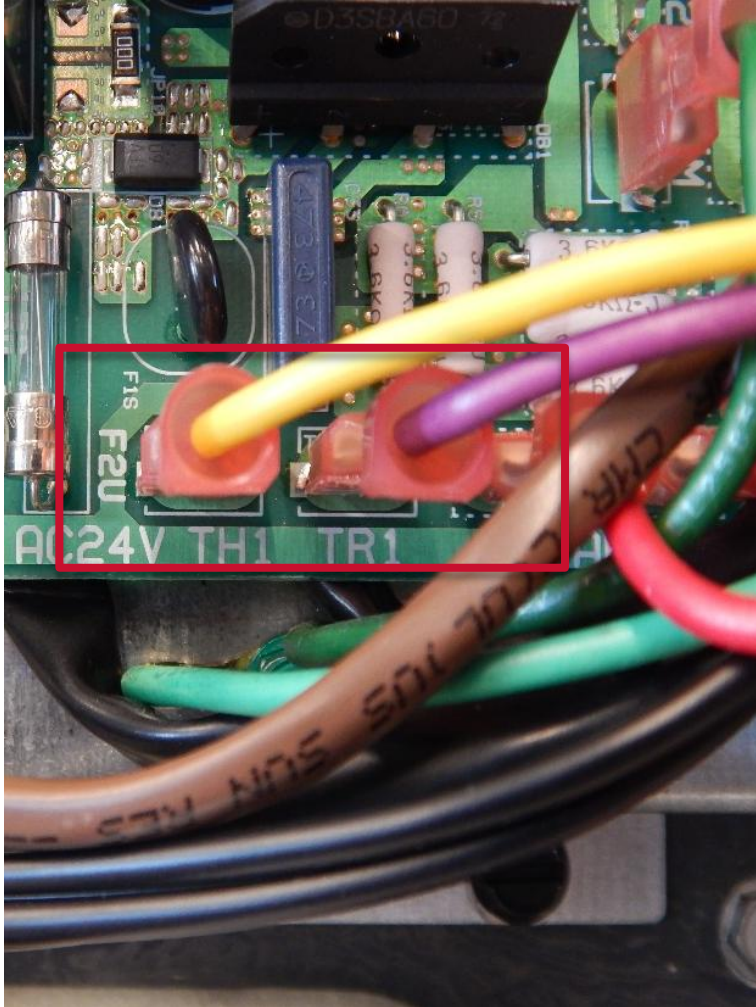

- This transformer supplies 24 VAC to the coil PCB's, via the yellow and purple wires in transformer kit.
- Do not supply high voltage to the EEV coil PCB, as it will cause a failure of the PCB.

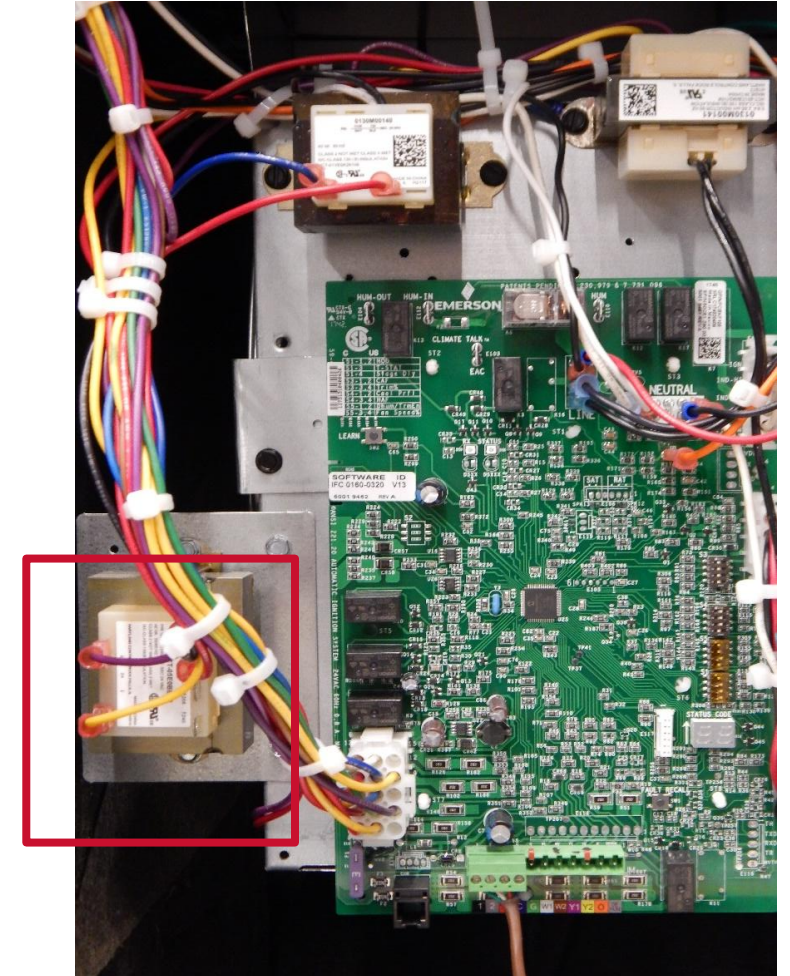

Agenda

Installation

Additional Transformer for PCB

Control Panel and Wiring



Board ID Connections and Dip Switches

X1A	Heater kit output (not used with furnaces)
X2A	Shared data port
X3A	Indoor EEV coil
X5A	Thermistor heat exchanger
X7A	Not used
X8A	Thermostat Input
X15A	Pressure Sensor
F1U	Fuse (3A) for aux alarm and heater output
F2U	Fuse (3.15A) protects PCB microchip (24VAC in)

TH1 & TR1	24VAC input via TR1 transformer (TB1/TB2)
TB4 & TB5	Auxiliary alarm (NOT active for Amana S Series)
TB6 & TB8	Accessory contacts (humidifier, etc.)
TB3 & TB7	Board common/ground
DS1	Not used
DS2	Not used
DS3	Not used
DS4	S15 Set to ON to enable normal EEV operation
DS5	EEV Factory Default Set to 50%
DS6	Set dip switches S-21 and S-22 for emergency mode

Control Panel and Wiring



CAPEA/CHPEA Control Module

- The control module is mounted on the exterior of the casing and is prewired.
 - Verify plugs and wires are secure on the board prior to powering the system.

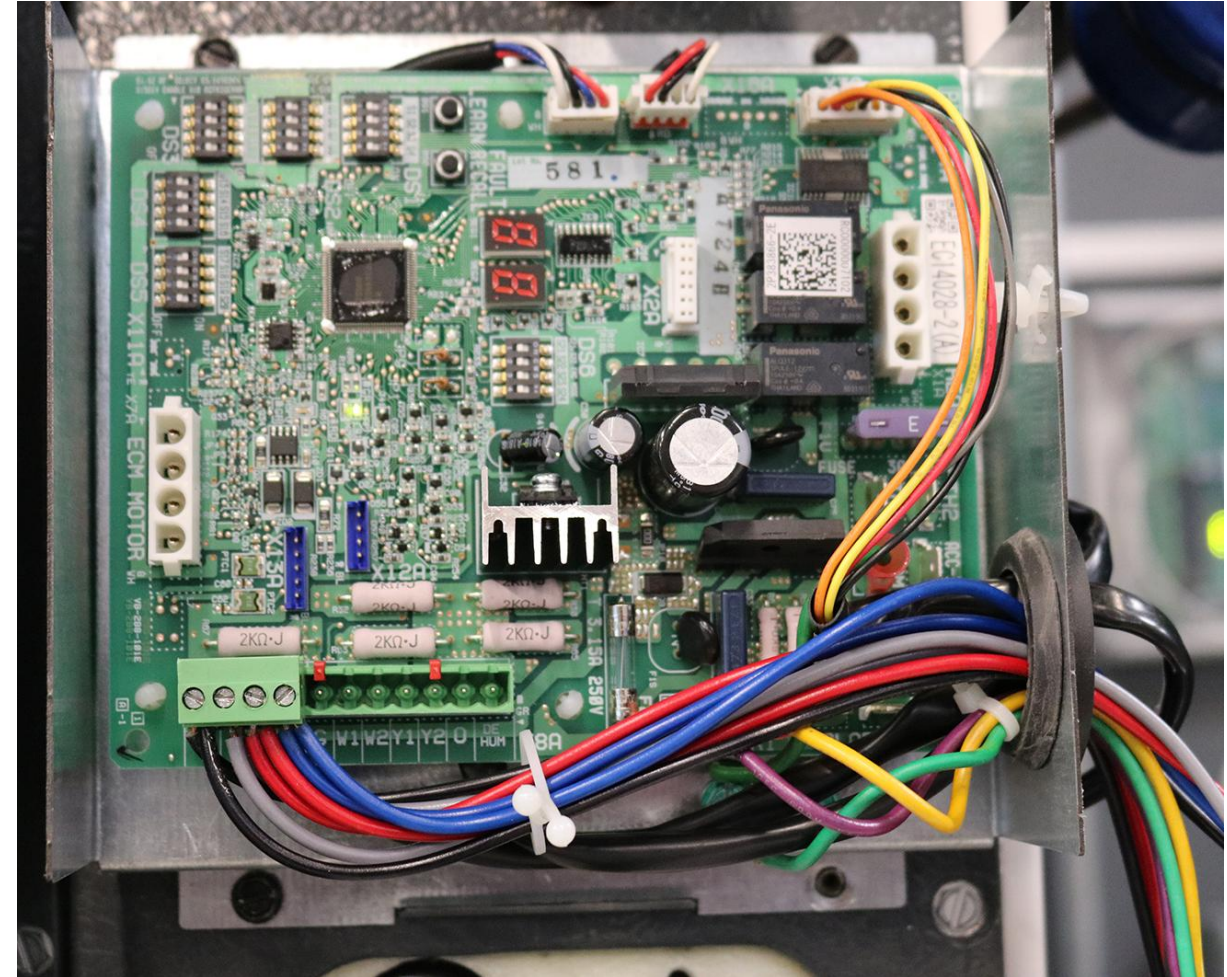

R32 (A2L) Sensor

Sensor Information

- Sensor bracket assemblies are shipped with two zip-ties, one of which is designed for strain relief. This zip-tie must be kept attached to bracket and wiring.
- It is the installers responsibility to ensure that mitigation mode is operational.
- Sensor is not intended for service or repair. If the sensor is not functioning properly, the sensor must be replaced by removing the old sensor from the bracket and re-installing the new sensor with new push pins and a zip tie.

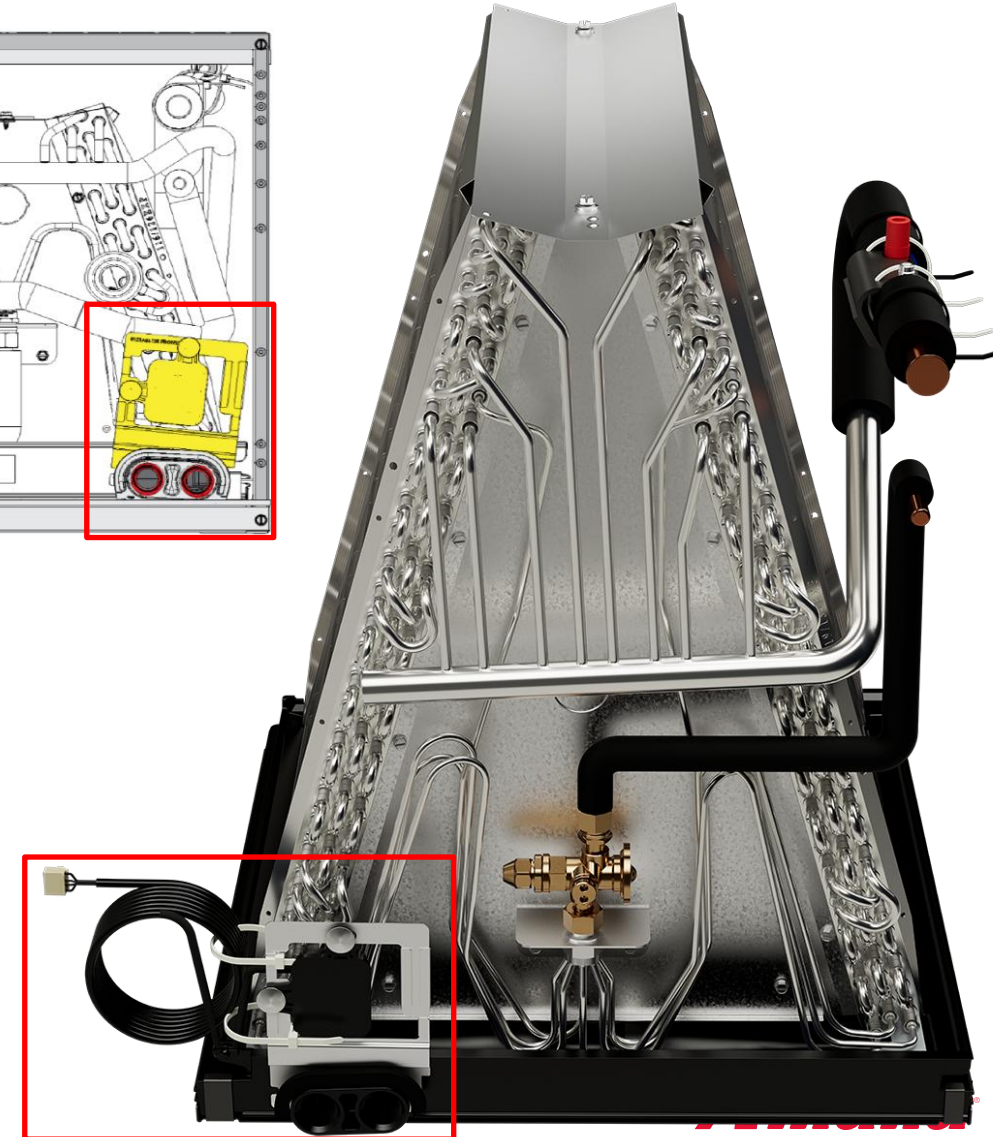
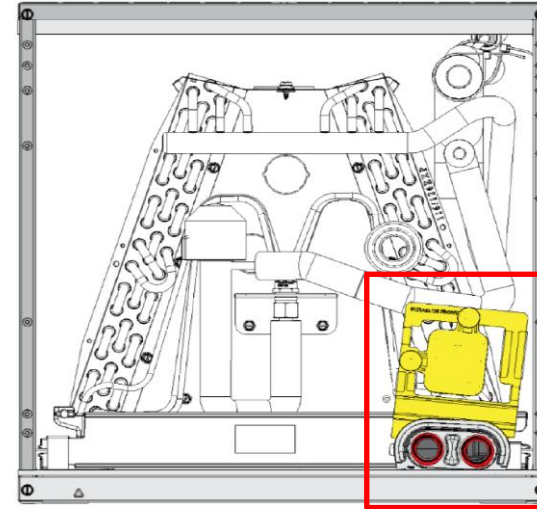



Sensor Testing

- To ensure the sensor is operational, the technician can check between pins 1 and 4. You should read 5VDC.
- Once voltage is verified, mitigation mode can be tested utilizing the refrigerant leak test mode found in the communicating thermostat menus.



PIN ASSIGN			
PIN Number	Function	Wire Color	Customer PIN Label
1	Ground/Common	Black	C
2	Data+ (A)	White	1
3	Data-(B)	Green	2
4	V Supply	Red	5 VDC

R32 (A2L) Sensor



Wire Routing

- The A2L sensor must be installed and powered for service. Ensure that the grommet is installed through the access panel knockout hole.
- If the furnace match is a non-A2L furnace, then a FIK(Furnace Integration Kit) must be utilized.
- For A2L furnaces, This wiring is intended to be passed through the access hole on the furnace. If a hole must be cut in to the furnace, ensure that the wiring is well protected from mechanical damage and that the hole is free from burrs or sharp edges. Utilize a protective coating for all exposed metallic edges.

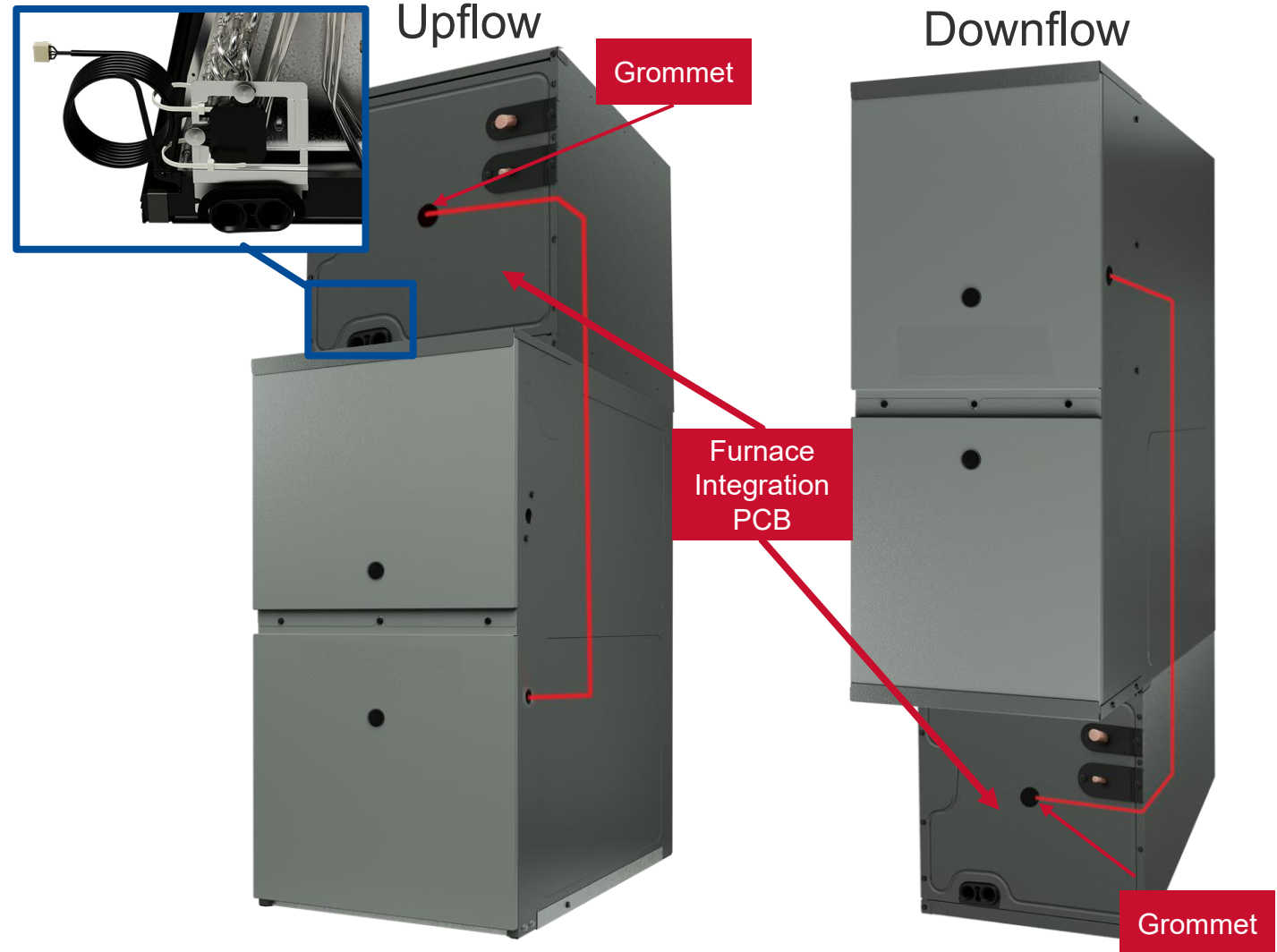



A **Heating & Air Conditioning** ***Amana***®



© 2024 Daikin Comfort Technologies North America, Inc.
Amana® is a registered trademark of Maytag Corporation or its related companies and is used under license.
All rights reserved.